

DEVELOPMENT PERMIT

Lewis County Community Development
2025 NE Kresky Avenue
Chehalis, WA 98532
360-740-1133 – Inspection line
360-740-1146 – Office
360-740-1245 - Fax
www.co.lewis.wa.us – web site

PERMIT NO.:	G17-00070
TYPE:	GRADING
SUB:	GRADING
ISSUED:	08/11/2017

Associated Permits: FD17-00180 / SHE17-0043

PROJECT DESCRIPTION: Emergency repairs / Boisfort Road Bank Protection - install 7 log jams to reinforce and protect right bank that is being eroded by river and threatening county roadway.

Cubic Yards of Fill/Grade: 431

General Location: BOISFORT ROAD - MP 4.152 to MP4.181

Tax Parcel No: 016024001003

Legal Description: Section 02 Township 12N Range 04W

APPLICANT: LEWIS COUNTY PUBLIC WORKS
2025 NE KRESKY AVE
CHEHALIS, WA 98532

OWNER: LEWIS COUNTY PUBLIC WORKS
2025 NE KRESKY AVE
CHEHALIS, WA 98532

Acknowledgement:

I certify that I have read and understand the following Conditions of Permit and Requirements for Final Inspection associated with this permit and agree to comply with all conditions.

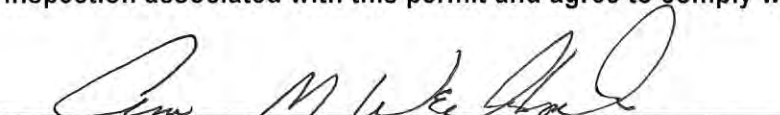
Signature : Owner Applicant Agent

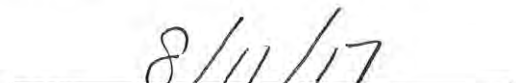
Date

CONDITIONS OF PERMIT

1. All work shall conform to the requirements of the Lewis County Code and any other applicable laws and ordinances.
2. Fill material is required to be clean earth material (rock, natural soil or a combination of both)

NOTICES

PERMIT EXPIRATION: This permit is valid for 180 days (6 months) from the date of issue. Extensions can be granted for a period of 180 days (6 months) with a written request to the Building Official and documentation of the amount of fill/grade completed to that date. Extensions will be granted for the amount of work remaining on the original permit. Additional fill or grade must be approved under separate permit.

PERMIT CHANGE REQUEST: Any change to the permit or the plans associated with this permit after the permit has been issued will be assessed a \$50.00 change fee. This fee will be in addition to any fees calculated for the change.

REFUNDS: The Building Official may authorize the refunding of not more than 80% of the base permit fee paid when no work has been done under a permit and upon written request filed by the original permittee not more than 180 days after the date of fee payment. Fees paid for plan reviews, state fees and Critical Areas / Resource Lands (CARL) reviews are non-refundable.

INSPECTIONS: The permit holder must notify the Building Official when construction has commenced to a point that inspection is appropriate. Failure to do so may result in fines and/or penalties being assessed. A minimum **twenty-four (24) hour notice** must be given to assure prompt inspection service. Inspections can be scheduled by calling the inspection line at 360-740-1133.

NOTICE TO CONTRACTORS: For all projects in unincorporated Lewis County, please report sales tax to CODE 2100. Projects in the City limits should be reported to the designated City codes. If you have questions call the Lewis County Treasurer's Office at 360-740-1116 or toll free (within Lewis County) at 1-800-562-6130 ext. 1116.

FLOODPLAIN DEVELOPMENT PERMIT

Lewis County Community Development

2025 NE Kresky Avenue

Chehalis, WA 98532

360-740-1133 – Inspection line

www.co.lewis.wa.us – web site

360-740-1146 – Office

360-740-1245 - Fax

PERMIT NO.: FD17-00180

TYPE: FLOOD PLAIN

ISSUED: 08/11/2017

Grading Permit: G17-00070

PROJECT DESCRIPTION: Emergency repairs / Boisfort Road Bank Protection - install 7 log jams to reinforce and protect right bank that is being eroded by river and threatening county roadway.

BASE FLOOD ELEVATION: N/A

LOWEST POSSIBLE BLDG ELEVATION: N/A

General Location: BOISFORT ROAD - MP 4.152 to MP4.181

Tax Parcel No: 016024001003

Legal Description: Section 02 Township 12N Range 04W

APPLICANT: LEWIS COUNTY PUBLIC WORKS
2025 NE KRESKY AVE
CHEHALIS,WA 98532

OWNER: LEWIS COUNTY PUBLIC WORKS
2025 NE KRESKY AVE
CHEHALIS, WA 98532

CONDITIONS OF PERMIT

1. All work shall conform to the requirements of the Lewis County Code and any other applicable laws and ordinances.
2. This permit becomes invalid upon the expiration date of the Fill & Grade permit associated with it.



Community Development

2025 NE Kresky Avenue
Chehalis WA 98532

August 7, 2008

Lewis County Public Works
2025 NE Kresky Ave
Chehalis, WA 98532

RE: Shoreline Exemption (SHE17-0043)

Dear Lewis County Public Works:

Enclosed please find a shoreline exemption permit for emergency bank protection for a roadway within the shoreline jurisdiction of the South Fork Chehalis River. This exemption covers only the requirements of a shoreline substantial development permit; all other relevant regulatory requirements still apply (WAC 173-27-040). Future projects are required to be reviewed and meet the applicable regulatory requirements.

Sincerely,

Karen Witherspoon, AICP
Senior Project Planner

Enclosure: Shoreline Exemption

**LEWIS COUNTY
EXEMPTION FROM SHORELINE MANAGEMENT ACT
SUBSTANTIAL DEVELOPMENT PERMIT REQUIREMENT**

TO: Lewis County Public Works
2025 NE Kresky Ave
Chehalis, WA 98532

RE: SHE17-0043

The proposal by LEWIS COUNTY PUBLIC WORKS to undertake the following development:

Emergency bank protection to protect roadway

within the shoreline jurisdiction of the South Fork Chehalis River and/or its associated wetlands, is exempt from the requirement of a Shoreline Substantial Development Permit because of WAC 173-27-040(2)(d).

THIS EXEMPTION IS APPROVED ONLY FOR THOSE ACTIVITIES DESCRIBED ABOVE. NO OTHER ACTIVITIES ARE COVERED BY THIS EXEMPTION. OTHER ACTIVITIES WITHIN SHORELINE JURISDICTION OF THE SOUTH FORK CHEHALIS RIVER MAY REQUIRE A SHORELINE PERMIT FROM LEWIS COUNTY.

The proposed development is consistent or inconsistent with: (check one)

CONSISTENT

INCONSISTENT

Policies of the Shoreline Management Act.
The Guidelines of the Department of Ecology.
The Master Program.

LEWIS CO. COMMUNITY DEVELOPMENT
PLANNING SECTION

Conditions of approval

1. This project is approved as a Shoreline Exemption under WAC 173-27-040(2)(d) for emergency construction. Upon abatement of the emergency situation, the new structure shall be removed or the applicant is required to apply for the permits that would be required if this was not an emergency situation.

08/07/2017
Date



Karen Witherspoon, Shorelines Administrator

LEWIS COUNTY
PLANNING REVIEW

Parcel No.:016024001003

Status: **Approved**
Applicant: LEWIS COUNTY PUBLIC WORKS
Review #: PR17-00522
Application #: FD17-00180, G17-00070, SHE17-0046
Project: Emergency repairs / Boistfort Road Bank Protection - Placement of 431 cy fill and install 7 logjams to reinforce and protect right bank that is being eroded by river and threatening county roadway.
Date: 08/10/2017

CONDITIONS OF DEVELOPMENT

Based upon review of the Lewis County Code Titles 15, 16 & 17, the following conditions apply to your project:

1. *Discharge of petroleum or hazardous materials to any ditch, swale, or other non-impervious surfaced area, where migration to an aquifer is reasonably likely, is prohibited.
2. *Buried tanks of any petroleum or hazardous materials shall be prohibited unless the tanks are double-walled and equipped with a leakage monitoring system. Installation of the system shall be certified by the Property Owner or his/her agent. Placement of any buried tanks shall be undertaken only when approval is granted by the Washington State Department of Ecology.
3. *Oil-water separators shall be required for new impervious surface areas of 5,000 square feet or larger.
4. *All development must comply with the requirements of Seismic Risk Zone D-1.
5. *Nothing of a commercial, business, or industrial nature will be constructed, maintained, or suffered to be constructed or maintained on the said land of the grantor(s).
6. *The applicant shall meet the minimum requirements of LCC Chapter 15.45, erosion and sediment control.
7. *The applicant shall obtain all other required local, state and federal permits and approvals.
8. Notice: This parcel is located in Flood Zone A, the 100-year flood plain; Flood Zone B, the 500-year flood plain; and Flood Zone C, typically areas are typically minimal flooding. FD17-00180 has been applied for. Development in these areas shall be consistent with the Lewis County Flood Damage Prevention Ordinance, LCC 15.35.
9. Notice: Portions of the parcel are located in the floodway. Development in that zone shall comply with the Lewis County Flood Damage Prevention Ordinance, LCC 15.35 and the Shoreline Master Program, LCC 17.25. FD17-00180 has been applied for.
10. The project is located within the jurisdiction of the Shoreline Management Act. Activities and development in that jurisdiction shall comply with the Lewis County Shoreline Master Program, LCC 17.25. SHE17-0043 has been applied for. The project is exempt for an emergency. Upon abatement of the emergency action, all permits are required that would have been required if this was not an emergency situation.
11. The current proposal is a low intensity use, and shall maintain a 50' setback from the ordinary high water mark of the Type 1 river or lake per LC 17.35. This LCC chapter applies to projects vested prior to December 2008 and/or lands zoned as Agricultural Resource Land (ARL). The current proposal is bank stabilization to protect the existing road.
12. NOTICE: The subject property is within or near land designated for long-term commercially significant resource land in which natural resource activities are permitted and encouraged, including a variety of activities that may not be compatible with residential or other types of development for certain periods extending beyond the normal workday and/or work week. In addition to other activities, these may include noise, dust, smoke, visual impacts, and odors. When performed in accordance with best management practices, these resource utilization activities are to be expected and shall not be subject to legal action or public nuisance.
13. Notice: Future development may require a wetland determination. The current proposal is more than 125 feet from the mapped wetland on site.

14. High intensity and special high intensity uses shall conform with the aquifer recharge areas element of the Lewis County Critical Areas, Lewis County Chapter 17.35A.
15. A cultural resources report was completed. The report is on file.
16. All development shall conform to the requirements of the Agricultural Resource Land Zoning District per Lewis County Code Title 17.30.



Karen Witherspoon
Senior Project Planner

Note: * denotes a general requirement

JARPA SUBMITTAL

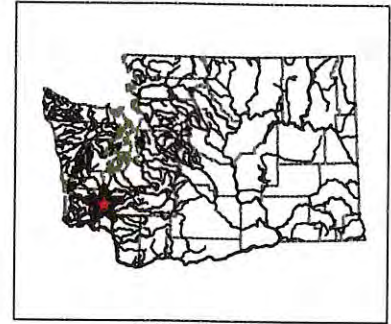

STATE MAP

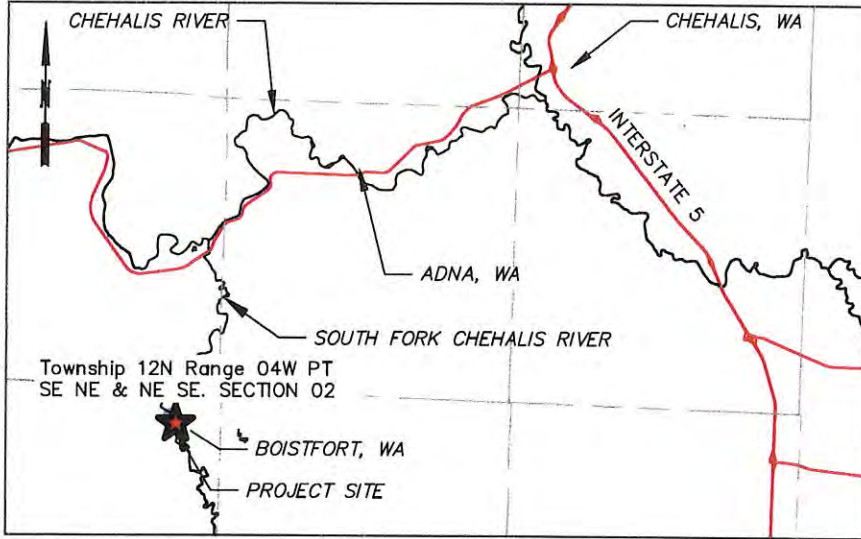

VICINITY MAP
1 INCH = 20,000 FEET

PROJECT OVERVIEW
1 INCH = 500 FEET

APPROVED
BY Mike White
DATE 7/21/17

RECEIVED

JUL 17 2017

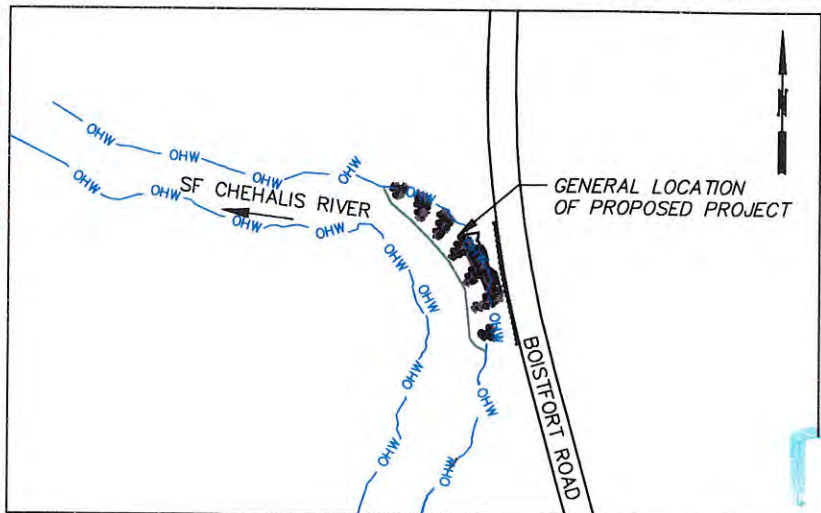

nhc PROJECT #: 2002962

REFERENCE:
APPLICANT:
Lewis County Public Works

LOCATION:
MP 4.152 - 4.181 Boistfort Road

PROPOSED PROJECT:
Bank Protection at Boistfort Road

ADJACENT PROPERTY OWNERS:
Rodney R. Lewis
Parcel Number: 016024001003

LAT/LONG: 46.552409, -123.135004

IN: *South Fork Chehalis River*
NEAR/AT: *Boistfort*
COUNTY: *Lewis*
STATE: *WA*

SHEET: 1 of 11 DATE: 07/12/17

NAME: *LCPW*
PERMIT #: *612-00020*
PARCEL #: *16024-1-3*

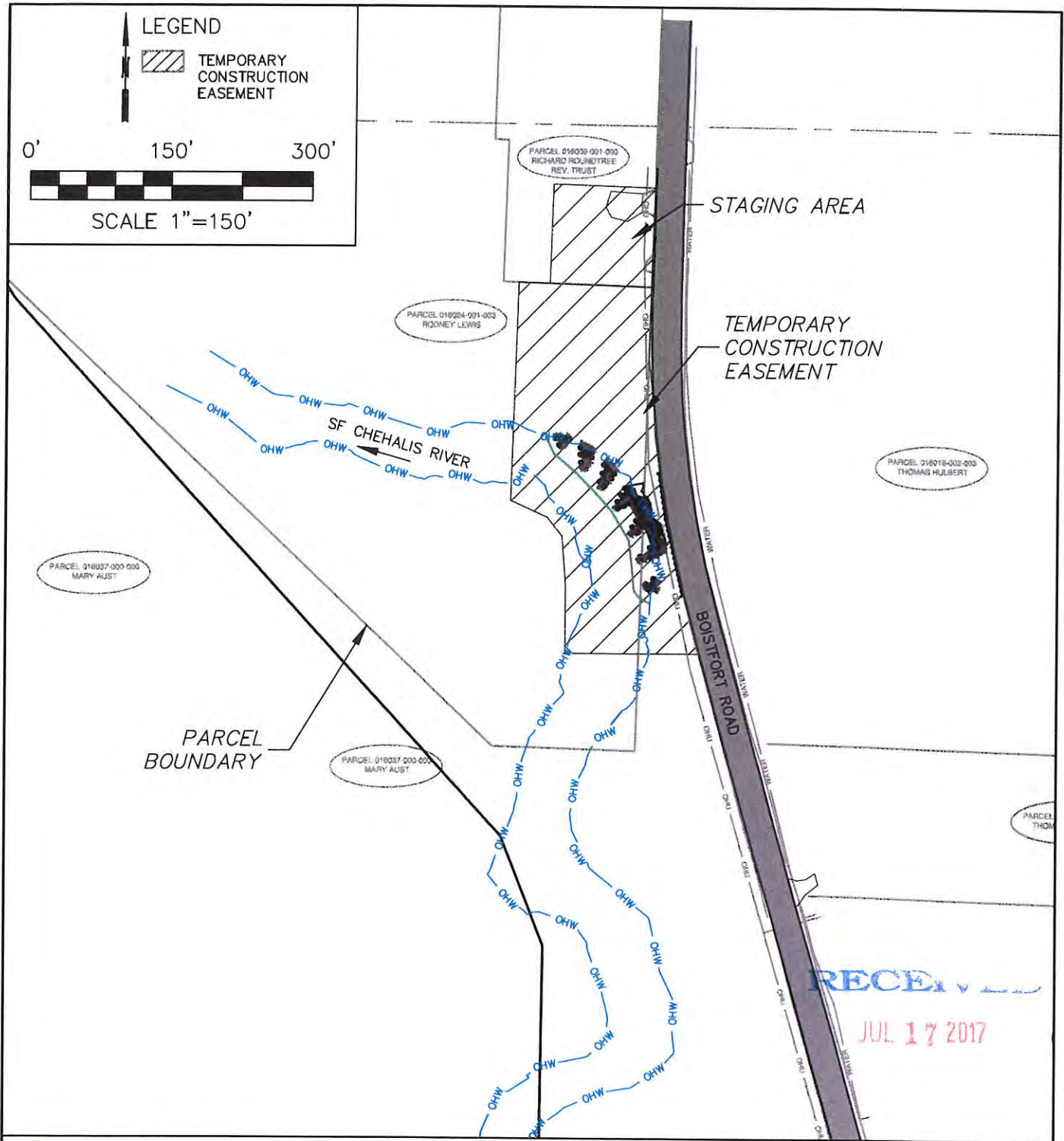

nhc PROJECT #: 2002962

REFERENCE:
APPLICANT:
 Lewis County Public Works

LOCATION:
 MP 4.152 - 4.181 Boistfort Road

PROPOSED PROJECT:
 Bank Protection at Boistfort Road

ADJACENT PROPERTY OWNERS:
 Rodney R. Lewis
 Parcel Number: 016024001003

LAT/LONG: 46.552409, -123.135004

IN: South Fork Chehalis River
NEAR/AT: Boistfort
COUNTY: Lewis
STATE: WA

SHEET: 2 of 11 **DATE:** 07/12/17

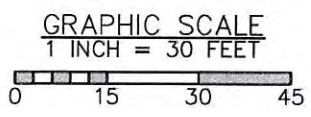
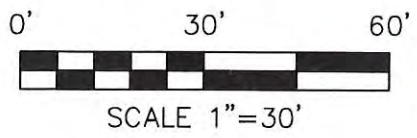
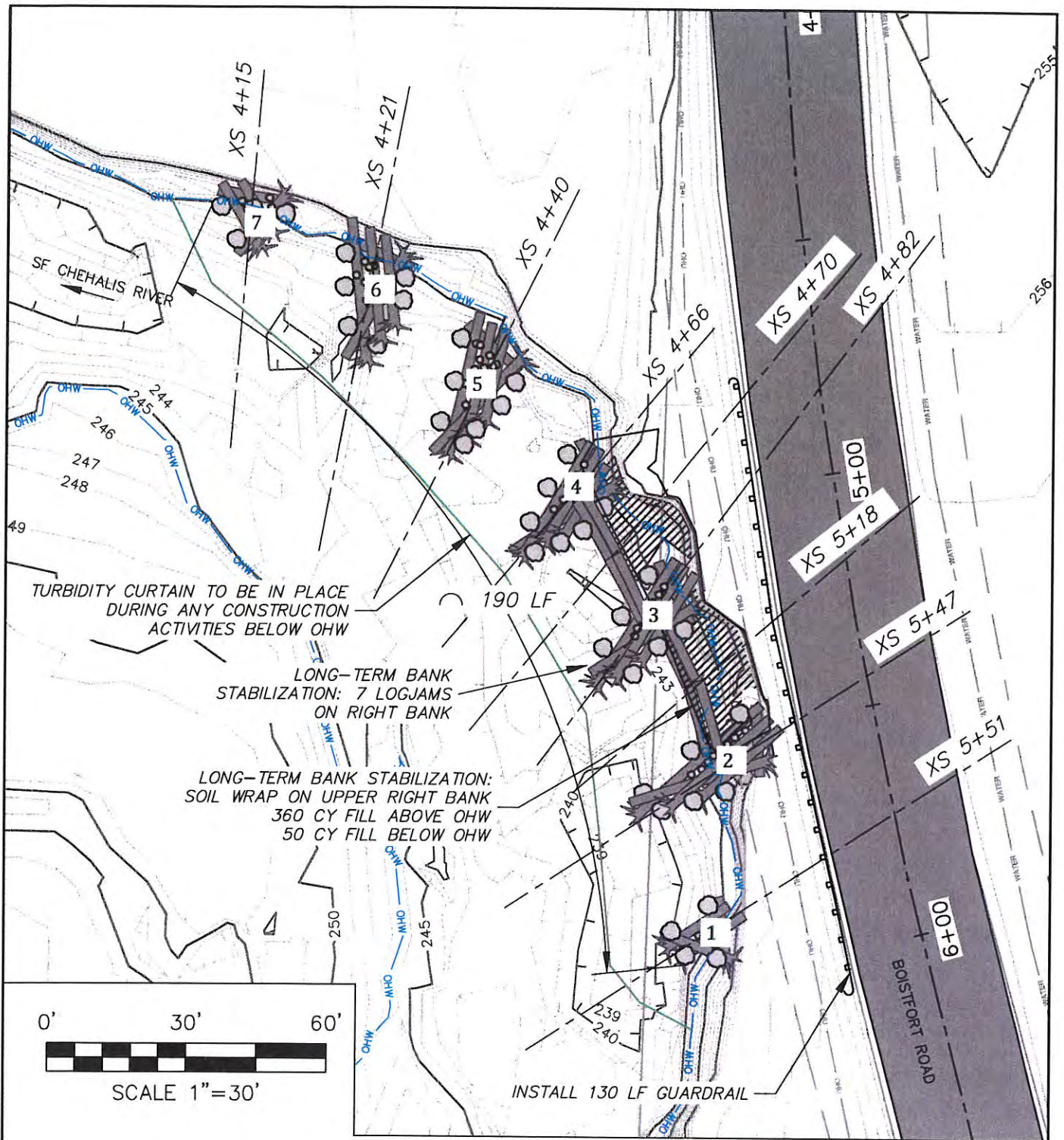

NAVD 88 VERTICAL
NAD 83/91 HORIZONTAL

nhc PROJECT #: 2002962

REFERENCE:

APPLICANT:
Lewis County Public Works

RECEIVED
JUL 17 2017

PROPOSED PROJECT:
Bank Protection at Boistfort Road

LOCATION:
MP 4.152 - 4.181 Boistfort Road

SHEET: 3 of 11

DATE: 07/12/17

JARPA SUBMITTAL

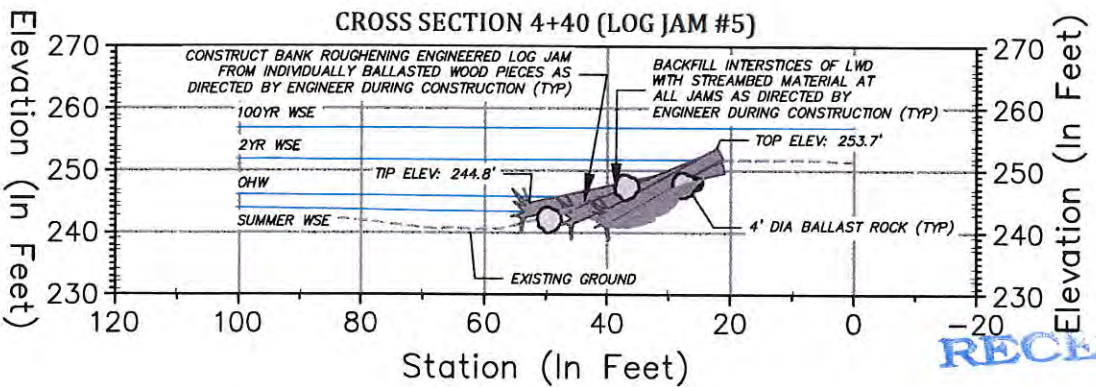
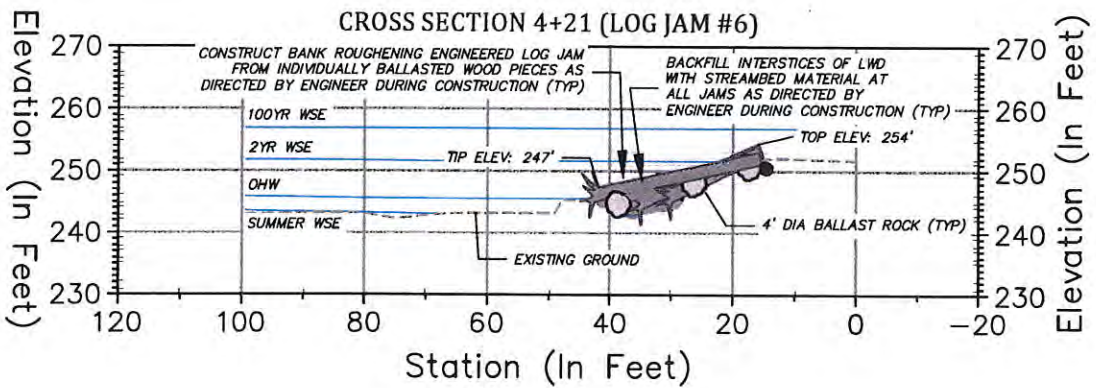
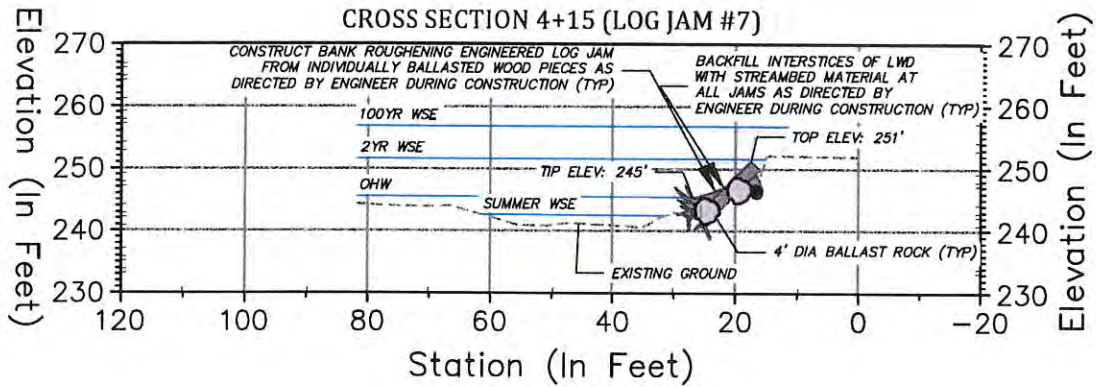

RECL
JUL 17 2017

JARPA SUBMITTAL

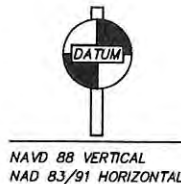
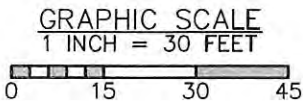

nhc PROJECT #: 2002962

REFERENCE:

APPLICANT:
Lewis County Public Works

PROPOSED PROJECT:
Bank Protection at Boistfort Road

LOCATION:
MP 4.152 - 4.181 Boistfort Road

SHEET: 4 of 11

DATE: 07/12/17

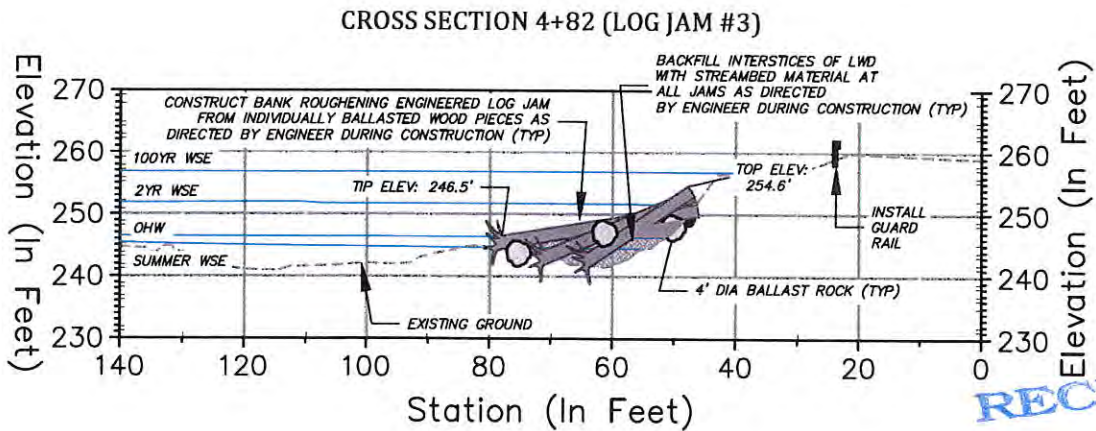
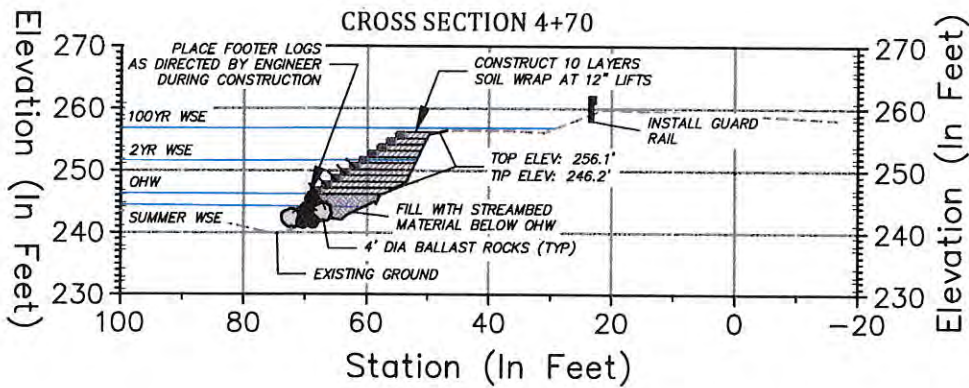
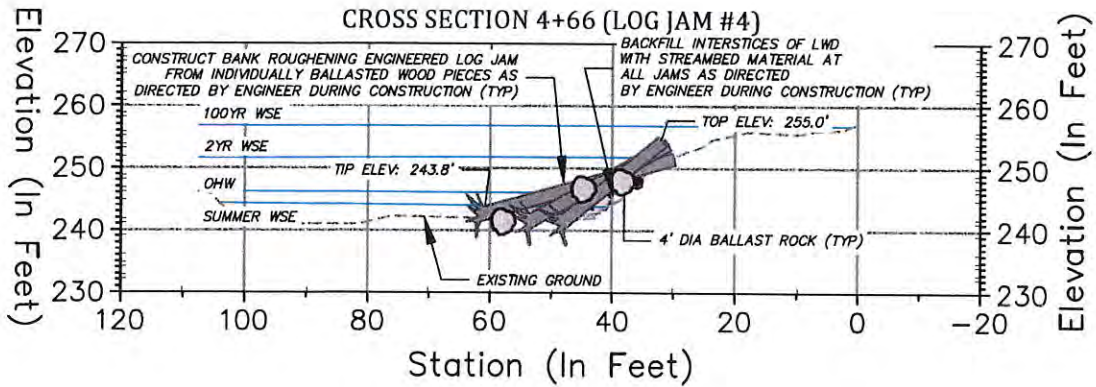

RECEIVED
JUL 17 2017

JARPA SUBMITTAL

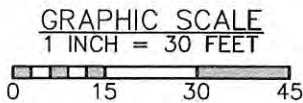

NAVD 88 VERTICAL
NAD 83/91 HORIZONTAL

nhc PROJECT #: 2002962

REFERENCE:

APPLICANT:
Lewis County Public Works

PROPOSED PROJECT:
Bank Protection at Boistfort Road

LOCATION:
MP 4.152 - 4.181 Boistfort Road

SHEET: 5 of 11

DATE: 07/12/17

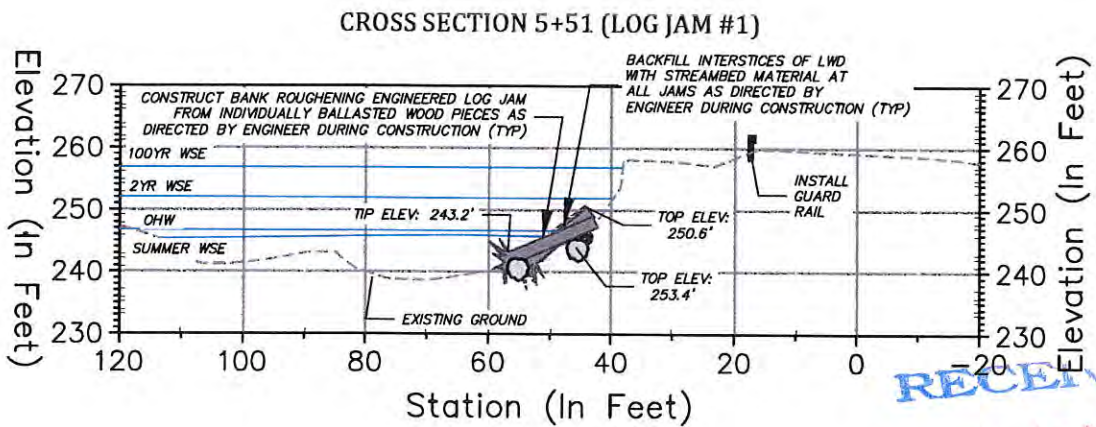
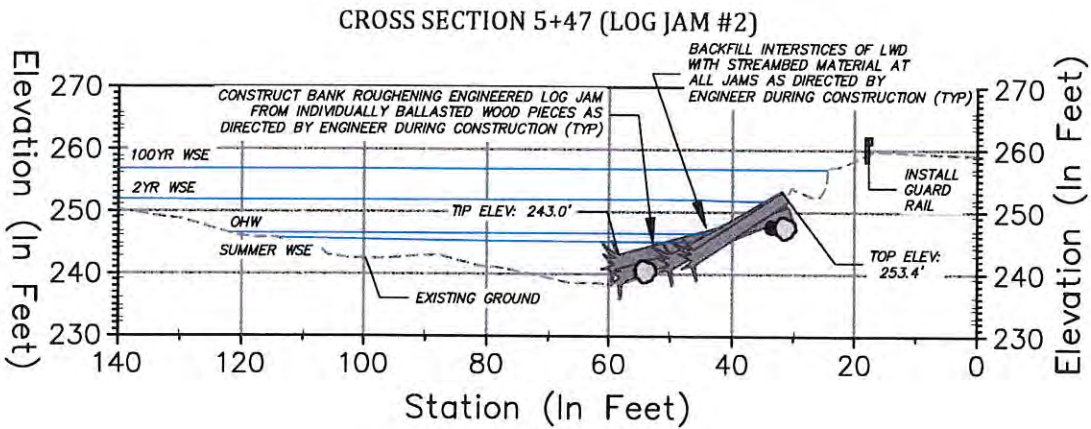
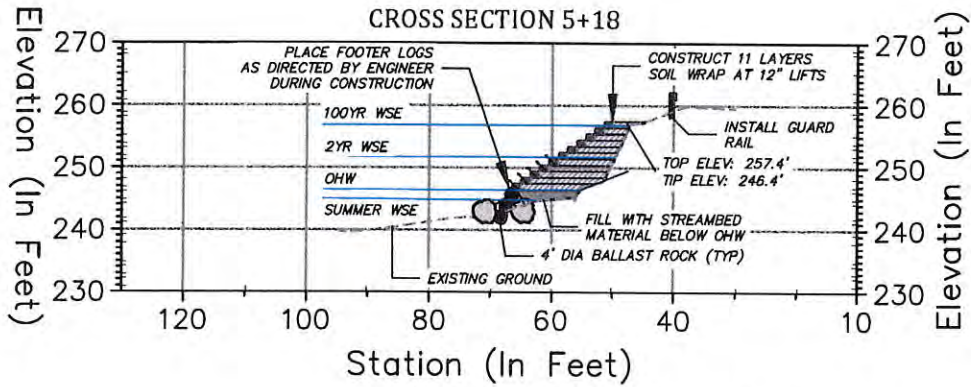

RECEIVED
JUL 17 2017

JARPA SUBMITTAL

nhc PROJECT #: 2002962

REFERENCE:

APPLICANT:
Lewis County Public Works

PROPOSED PROJECT:
Bank Protection at Boistfort Road

LOCATION:
MP 4.152 - 4.181 Boistfort Road

SHEET: 6 of 11

DATE: 07/12/17

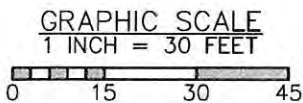

LOG DETAIL

INDIVIDUALLY BALLAST EACH LOG BY ATTACHING TO BOULDER AS SHOWN IN DETAIL. THEN PLACE LOG AND BALLAST INTO FINAL LOCATION AS DIRECTED BY THE ENGINEER.

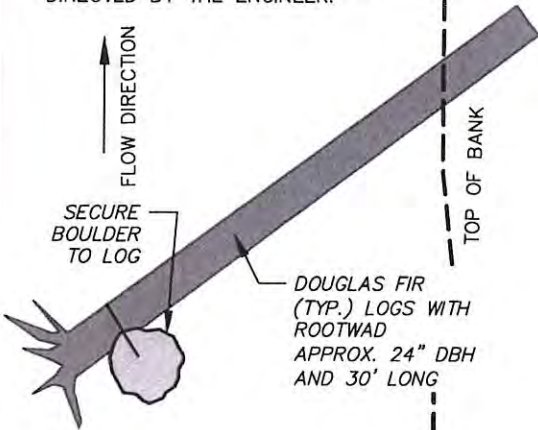

LOG JAM DETAIL

NOTE:

LOG JAMS 2 - 6 MATERIALS:

- 4 x LOGS WITH ROOTWAD, 24" DBH, 20 TO 30' LONG
- 1 x FOOTER LOGS, 24" DBH, 15' LONG
- 7 x 4 MAN (48") BALLAST ROCKS

LOG JAMS 1 & 7 MATERIALS:

- 3 x LOGS WITH ROOTWAD, 24" DBH, 15' LONG
- 1 x FOOT LOGS, 24" DBH, 15' LONG
- 4 x 4 MAN (48") BALLAST ROCKS

FILL VOLUME:

LOG JAM @ STA	STREAMBED MATERIAL FILL VOLUME, CY		# OF 4' Ø BALLAST ROCK	
	BELOW OHW	ABOVE OHW	BELOW OHW	ABOVE OHW
4+15	6.2	0.9	2	2
4+21	5.6	4.4	4	3
4+40	13.3	4.0	4	3
4+66	4.4	2.2	4	3
4+82	16.2	5.6	4	3
5+47	13.3	4.4	4	3
5+51	2.2	0.9	4	0
TOTAL	61.2 CY	22.4 CY	32.3 CY	21.1 CY

CABLE ALL LOG CROSSINGS (TYP)
 FILL LOG JAM VOID WITH STREAMBED MATERIAL

4' DIA BALLAST ROCKS PLACE AS DIRECTED BY ENGINEER IN THE FIELD

INSTALL 2 MANTA-RAY ANCHORS (TYP)

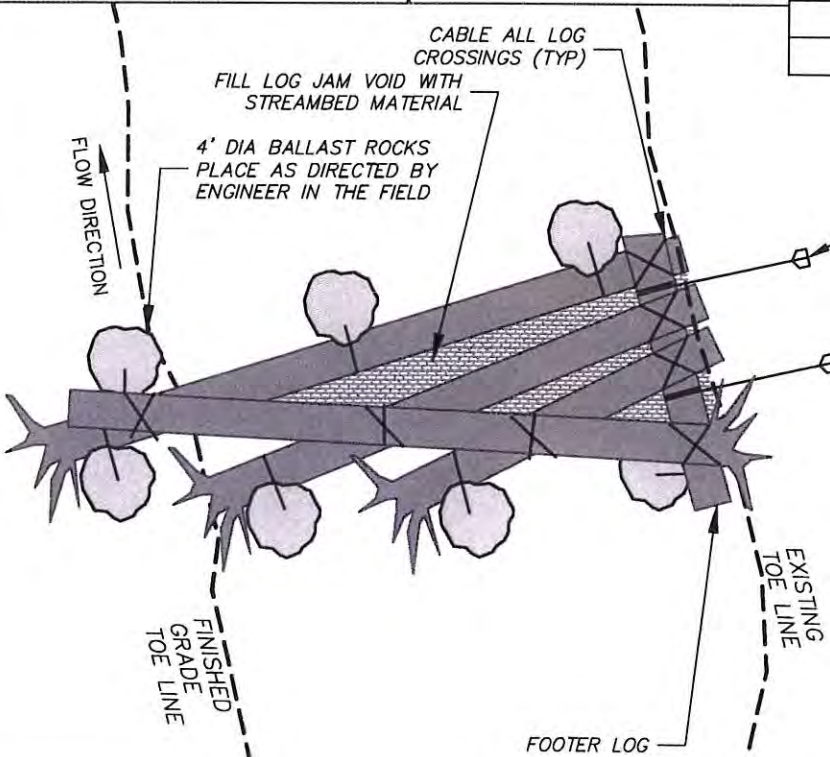

RECEIVED

JUL 17 2017

JARPA SUBMITTAL

nhc PROJECT #: 2002962

REFERENCE:

APPLICANT:
 Lewis County Public Works

PROPOSED PROJECT:
 Bank Protection at Boistfort Road

LOCATION:
 MP 4.152 - 4.181 Boistfort Road

SHEET: 7 of 11 DATE: 07/12/17

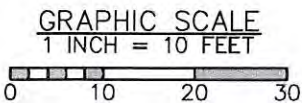

NAVD 88 VERTICAL
 NAD 83/91 HORIZONTAL

BOULDER TO LWD CONNECTION DETAIL

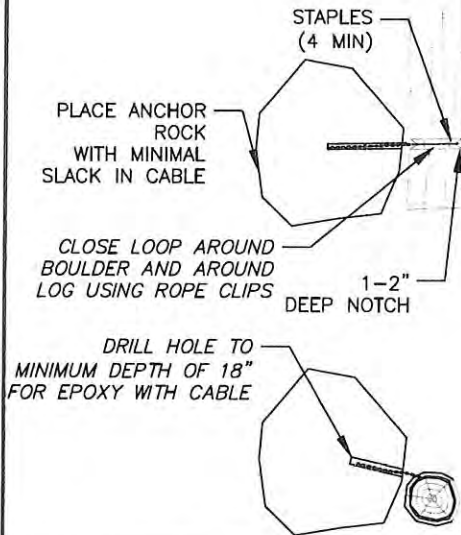

LOG TO EARTH ANCHOR CONNECTION

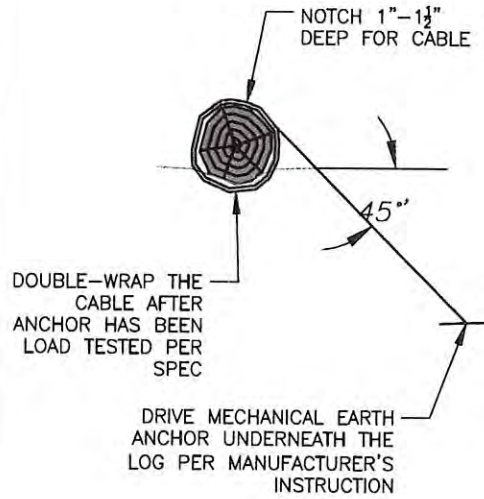

LOG TO LOG CONNECTION

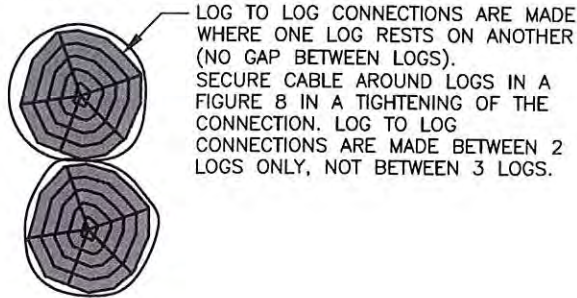

RECEIVED

JUL 17 2017

JARPA SUBMITTAL

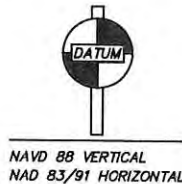
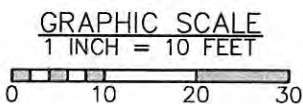

nhc PROJECT #: 2002962

REFERENCE:

APPLICANT:
Lewis County Public Works

PROPOSED PROJECT:
Bank Protection at Boistfort Road

LOCATION:
MP 4.152 - 4.181 Boistfort Road

SHEET: 8 of 11

DATE: 07/12/17

**LOG JAM
CONSTRUCTION
SEQUENCE (STEP 1)**

PLACE 4' DIA BALLAST
ROCK FOR ROOTWAD #1,
SEE DETAIL ON SHEET 7
(X2)

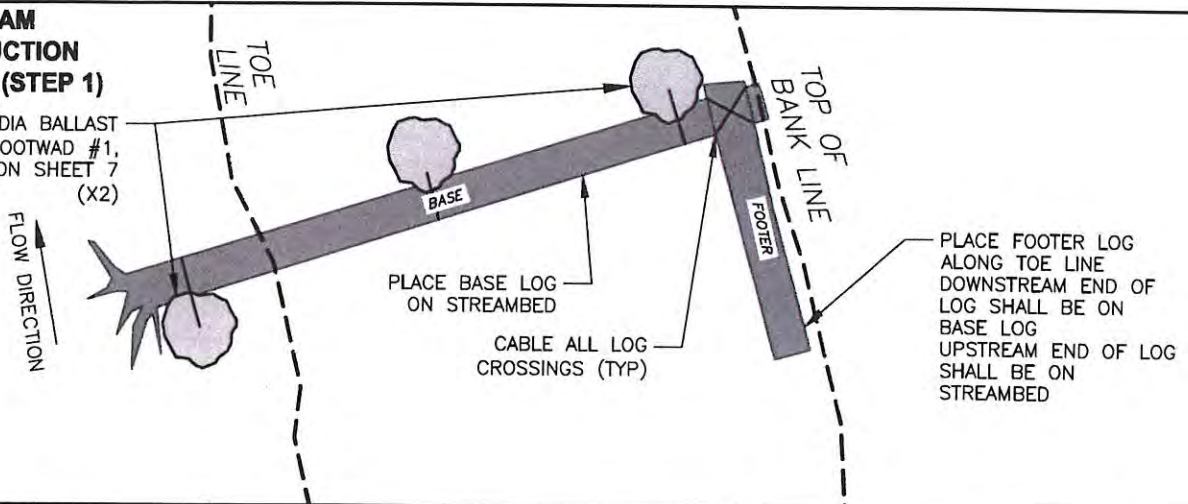

**LOG JAM
CONSTRUCTION
SEQUENCE (STEP 2)**

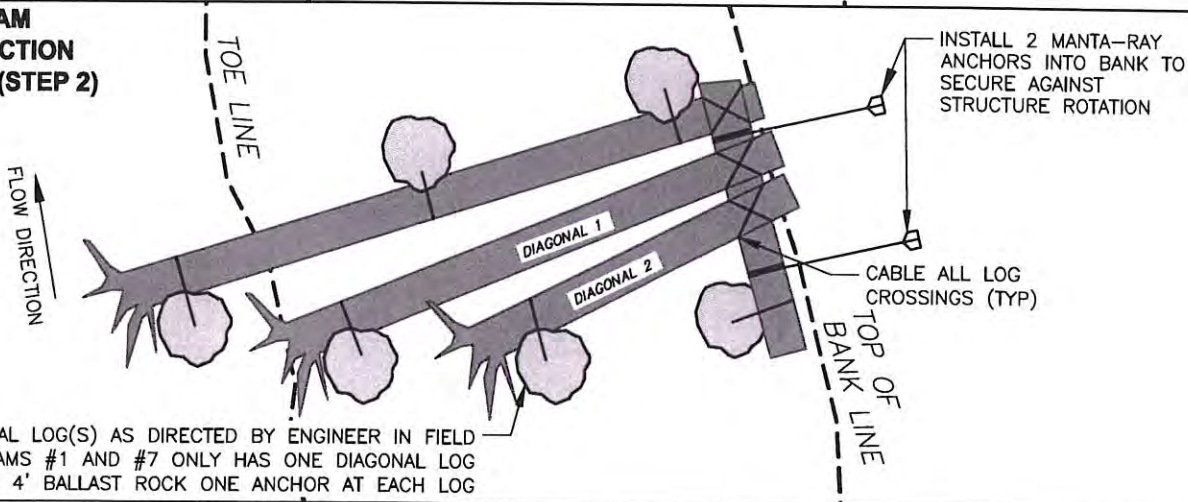

PLACE DIAGONAL LOG(S) AS DIRECTED BY ENGINEER IN FIELD
LOG JAMS #1 AND #7 ONLY HAS ONE DIAGONAL LOG
WITH ONE 4' BALLAST ROCK ONE ANCHOR AT EACH LOG

**LOG JAM
CONSTRUCTION
SEQUENCE (STEP 3)**

PLACE 4' DIA BALLAST
ROCK FOR ROOTWAD #1,
SEE DETAIL ON SHEET 7
(X2)

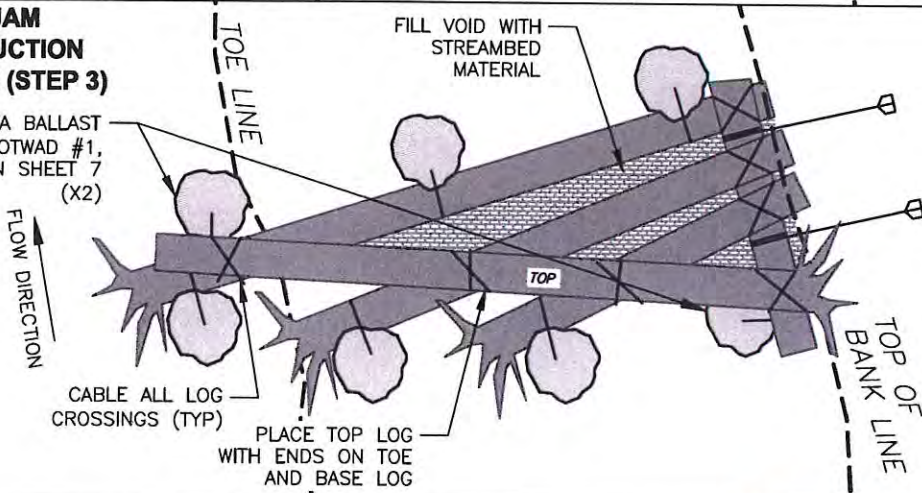

RECEIVED
JUL 17 2017

JARPA SUBMITTAL

nhc PROJECT #: 2002962

REFERENCE:

APPLICANT:
Lewis County Public Works

PROPOSED PROJECT:
Bank Protection at Boistfort Road

LOCATION:
MP 4.152 - 4.181 Boistfort Road

SHEET: 9 of 11

DATE: 07/12/17

GRAPHIC SCALE
1 INCH = 10 FEET



NAVD 88 VERTICAL
NAD 83/91 HORIZONTAL

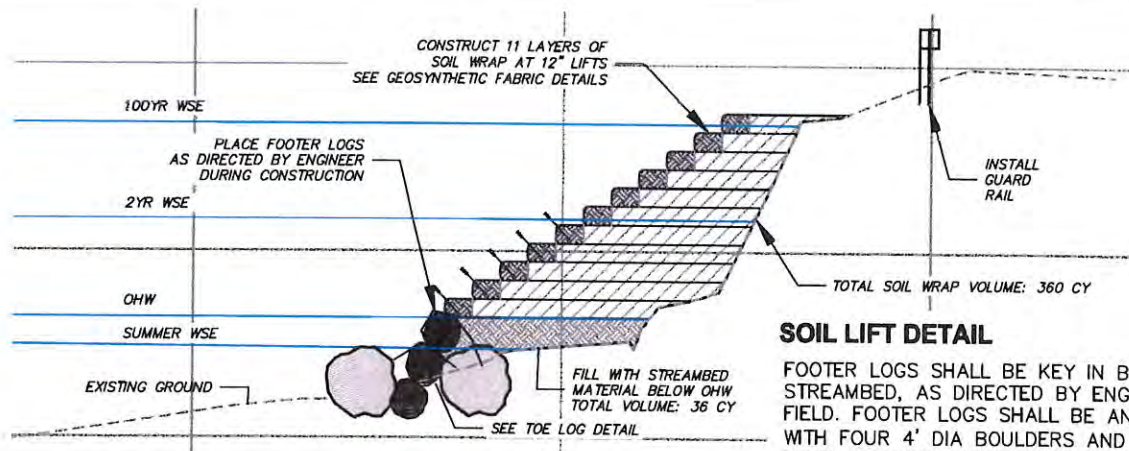

SOIL LIFT DETAIL

FOOTER LOGS SHALL BE KEY IN BELOW STREAMBED, AS DIRECTED BY ENGINEER IN FIELD. FOOTER LOGS SHALL BE ANCHORED WITH FOUR 4' DIA BOULDERS AND CREATE LEVEL BUILDING SURFACE WITH STREAMBED MATERIAL (SEE TABLE FOR GRADATION)

LOG JAM @ STA	STREAMBED MATERIAL FILL VOLUME, CY	
	BELOW OHW	ABOVE OHW
4+66 TO 4+82	25.8	164.0
4+82 TO 5+47	14.3	196.4
ROCKS	10 CY (8X 4' DIA)	-
TOTAL	50.1	360.0

STREAMBED MATERIAL GRADATION	
% FINER BY WEIGHT	PARTICLE SIZE
99-100%	12 IN
70-90%	10 IN
30-60%	5 IN
10%	0.75 IN

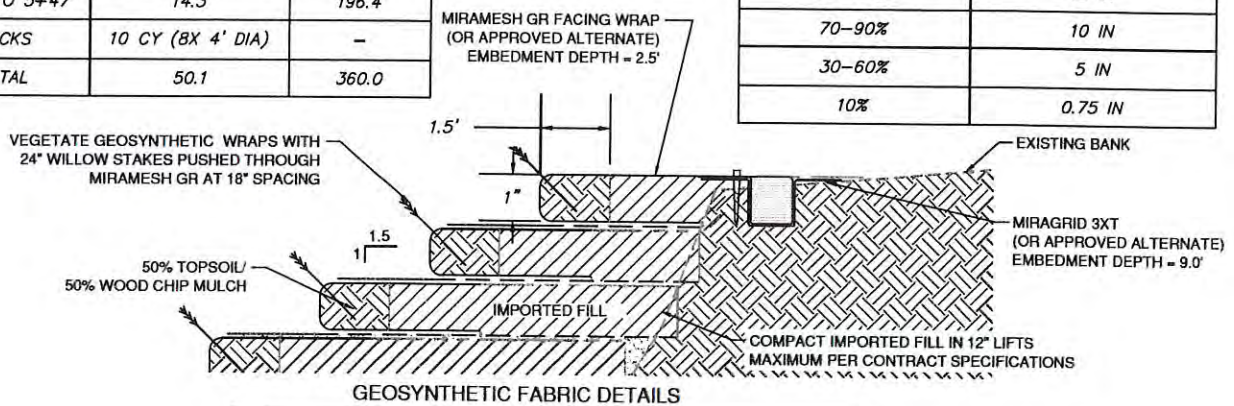

N.T.S.

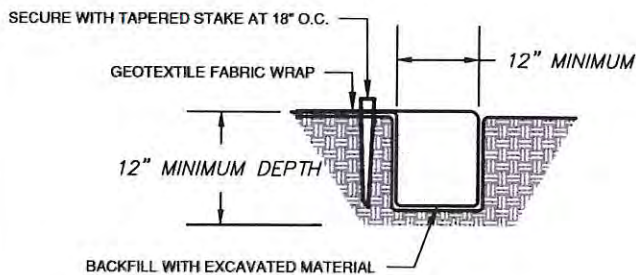

GEOSYNTHETIC FABRIC CUT-OFF TRENCH

N.T.S.

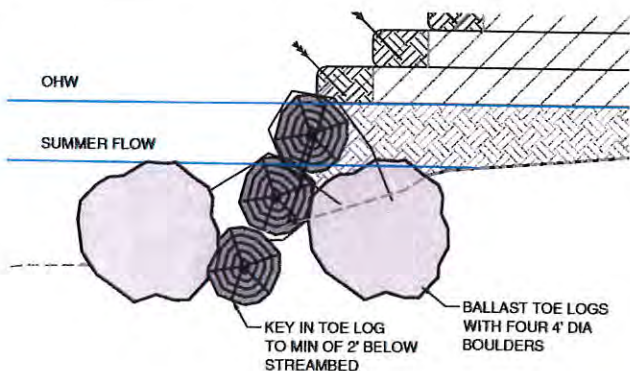

TOE LOG DETAIL

N.T.S.

JARPA SUBMITTAL



NAVD 88 VERTICAL
NAD 83/91 HORIZONTAL

nbc PROJECT #: 2002962

REFERENCE:

APPLICANT:
Lewis County Public Works

PROPOSED PROJECT:
Bank Protection at Boistfort Road

LOCATION:
MP 4.152 - 4.181 Boistfort Road

SHEET: 10 of 11 **DATE: 07/12/17**

RECEIVED
JUL 17 2017

8E. SUMMARIZE IMPACT(S) TO EACH WATERBODY IN THE TABLE BELOW.

ACTIVITY (CLEAR, DREDGE, FILL, PILE, DRIVE, ETC)	WATERBODY NAME	IMPACT LOCATION	DURATION OF IMPACT	AMOUNT OF MATERIAL (CY) TO BE PLACED IN OR REMOVED FROM WATER BODY	AREA (SF OR LF) OF WATERBODY DIRECTLY AFFECTED
PLACEMENT OF LWD	SF CHEHALIS RIVER	BELOW OHW	PERMANENT	41.3	190 LF
PLACEMENT OF STREAMBED MATERIAL	SF CHEHALIS RIVER	BELOW OHW	PERMANENT	61.2	190 LF
PLACEMENT OF BALLAST ROCKS (3 OR 4-MAN ROCK)	SF CHEHALIS RIVER	BELOW OHW	PERMANENT	32.3	190 LF
PLACEMENT OF SOIL WRAP	SF CHEHALIS RIVER	BELOW OHW	PERMANENT	50.1	190 LF
			TOTAL	185.0	
PLACEMENT OF LWD	SF CHEHALIS RIVER	ABOVE OHW WITHIN 100-YR FLOODPLAIN	PERMANENT	27.6	190 LF
PLACEMENT OF STREAMBED MATERIAL	SF CHEHALIS RIVER	ABOVE OHW WITHIN 100-YR FLOODPLAIN	PERMANENT	22.4	190 LF
PLACEMENT OF BALLAST ROCKS (3 OR 4-MAN ROCK)	SF CHEHALIS RIVER	ABOVE OHW WITHIN 100-YR FLOODPLAIN	PERMANENT	21.1	190 LF
PLACEMENT OF SOIL WRAP	SF CHEHALIS RIVER	ABOVE OHW WITHIN 100-YR FLOODPLAIN	PERMANENT	360.0	190 LF
			TOTAL	431.1	

RECEIVED

JUL 17 2017

JARPA SUBMITTAL



NAVD 88 VERTICAL
NAD 83/91 HORIZONTAL

nhc PROJECT #: 2002962

REFERENCE:

APPLICANT:
Lewis County Public Works

PROPOSED PROJECT:
Bank Protection at Boistfort Road

LOCATION:
MP 4.152 - 4.181 Boistfort Road

SHEET: 11 of 11 DATE: 07/12/17

SOUTH FORK CHEHALIS RIVER AT BOISTFORT ROAD MP 4.152 BANK PROTECTION

SHEET INDEX	
SHEET NO.	DESCRIPTION
1	COVER SHEET
2	SURVEY CONTROL AND OWNERSHIP SHEET
3	PLAN SHEET
4	TYPICAL SHEET
5	LOGJAM DETAILS
6	BANK STABILIZATION DETAILS

Lewis County Department of Public Works

APPROVED FOR CONSTRUCTION

Assistant County Engineer

8-7-16

(date)

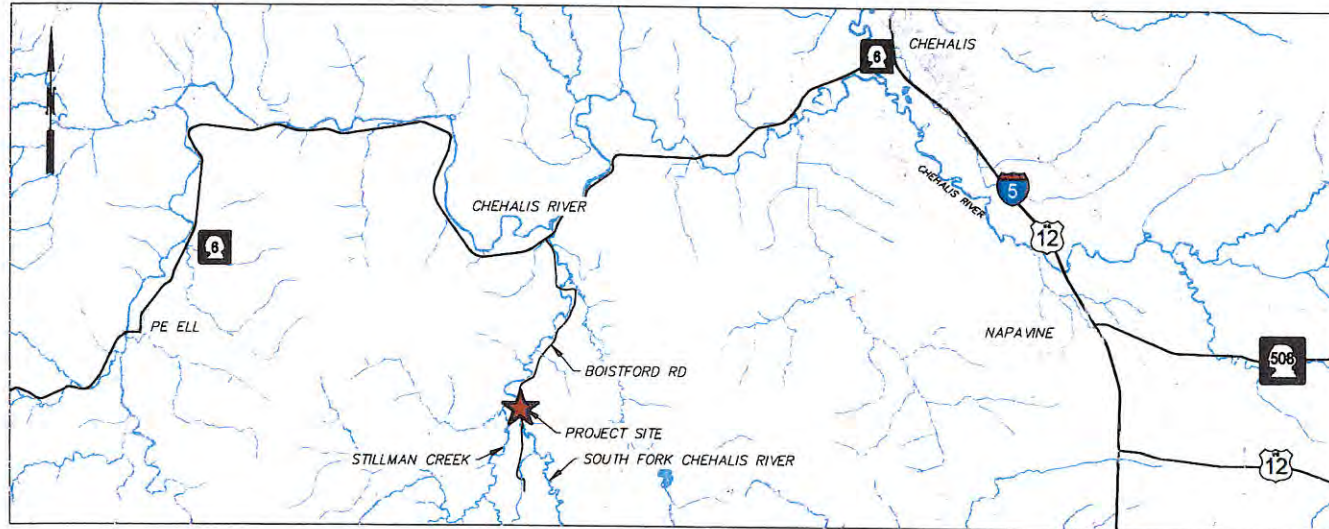

VICINITY MAP
1 INCH = 10,000 FEET

LEGEND

EXISTING OVERHEAD UTILITIES	— 1/4" —
EXISTING RIGHT-OF-WAY	— ··· —
EXISTING PAVED ROAD	— ··· —
EXISTING ROAD CENTERLINE	— ··· —
EXISTING CONTOURS (MAJOR)	— 350 —
EXISTING CONTOURS (MINOR)	— ··· —
EXISTING FENCE	— ··· —
EXISTING ORDINARY HIGH WATER	— ··· —
EXISTING STRUCTURES	— ··· —
FINISHED CONTOURS	— 1+00 —
CREEK ALIGNMENT	— ··· —
GEOSYNTHETIC WRAPS	▨
TREE PROTECTION	▨
TOP SOIL	▨

ABBREVIATIONS	
FT	FEET
EA	EACH
LF	LINEAR FEET
SY	SQUARE YARD
CY	CUBIC YARD
WSEL	WATER SURFACE ELEVATION
ROW	RIGHT OF WAY
OHW	ORDINARY HIGH WATER
EP	EDGE OF PAVEMENT
EL	ELEVATION
ELJ	ENGINEERED LOG JAM
DSTOP	TOP OF LOG ON DOWNSTREAM SIDE
USTOP	TOP OF LOG ON UPSTREAM SIDE
TIP	TIP OF ROOTWAD
VRSSLT	VEGETATED REINFORCED STEEP SLOPE WITH LOG TOE

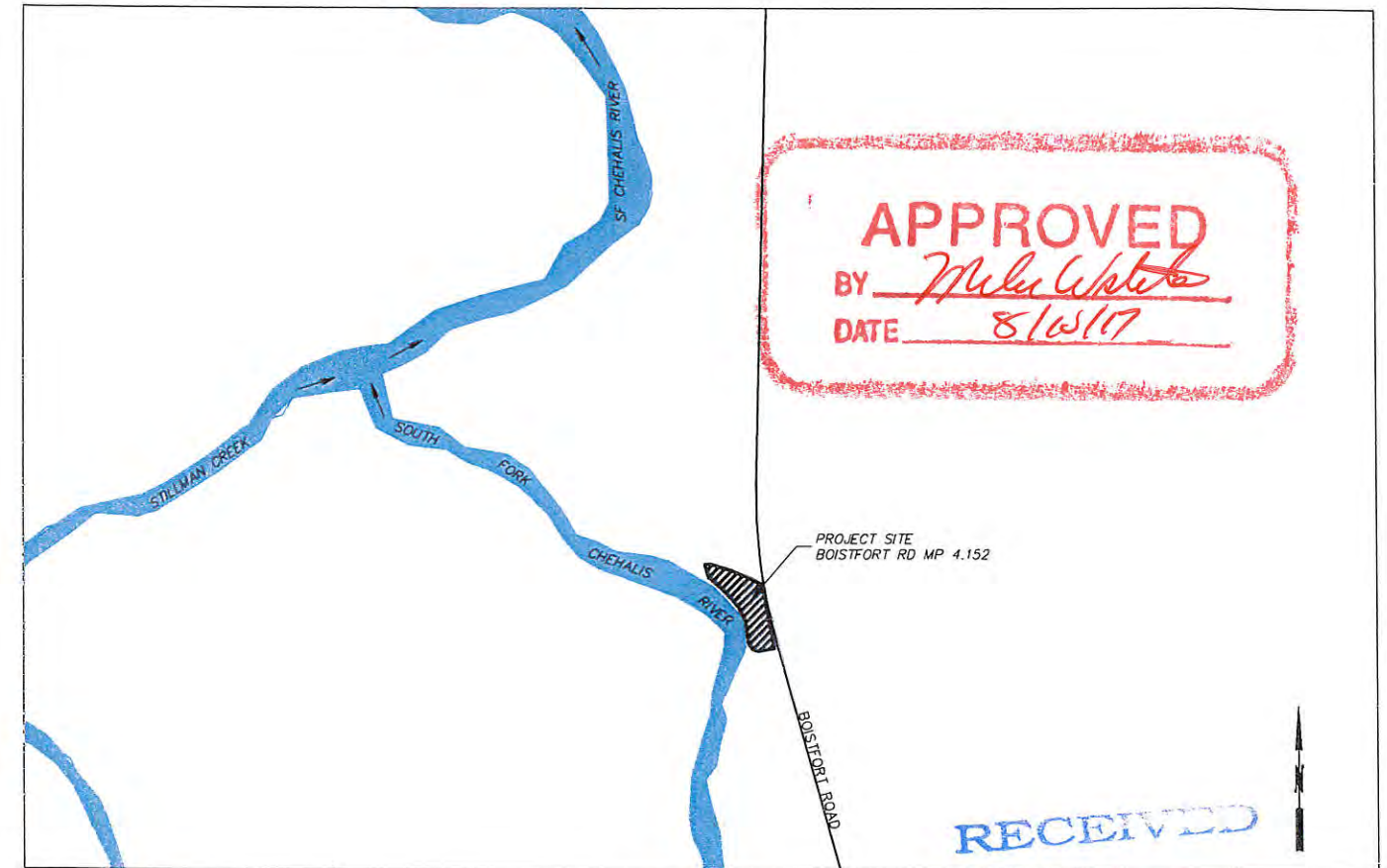

VICINITY MAP
1 INCH = 200 FEET



ERIK R. ROWLAND
WASHINGTON REGISTERED
PROFESSIONAL ENGINEER NO. 41862
northwest hydraulic consultants



NAVD 88 VERTICAL
NAD 83/91 HORIZONTAL

Lewis County
Department of Public Works
2025 N. E. KRESKY AVE.
CHEHALIS WA 98532
PHONE # (360) 740-1123
FAX # (360) 740-2719

DESIGNED BY: JJP
DRAWN BY: TVS
CHECKED BY: BGW
DATE: 18 JULY 2017

NO.	DATE	REVISION	BY	APP.

South Fork Chehalis River at Boistfort Road
MP 4.152 Bank Protection

COUNTY MAINTENANCE PROJECT NO: 1706

COVER SHEET

SHEET
1
OF
6

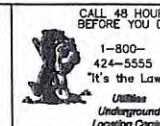

CALL 48 HOURS
BEFORE YOU DIG
1-800-424-5555
12787 Gateway Drive S.
Seattle, WA 98168
Phone: 206-241-6000

NAME: LCPW-final
PERMIT #: 417-00020
PARCEL #: 160241-3

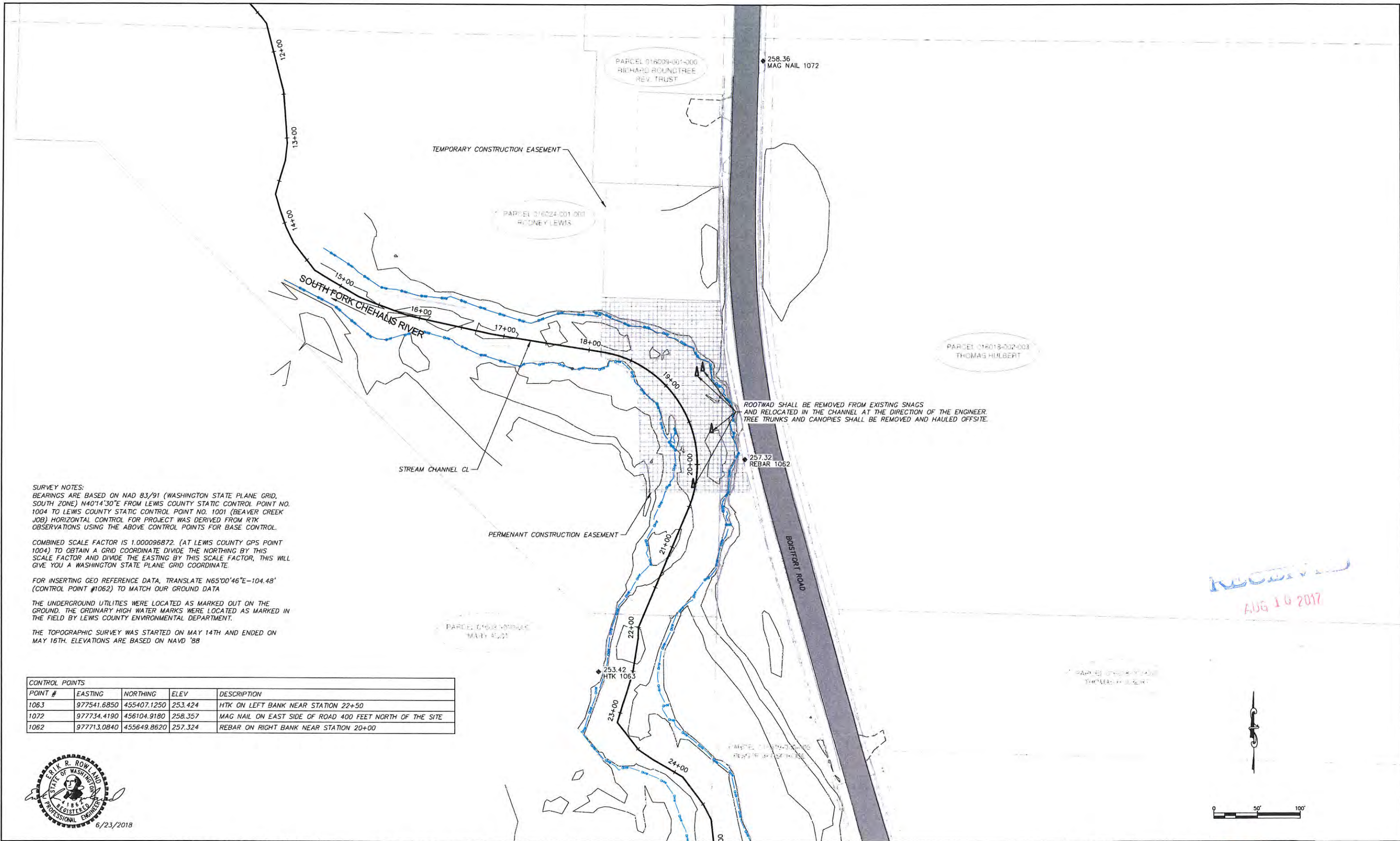

Reviewed
AUG 10 2017

SURVEY NOTES:
 BEARINGS ARE BASED ON NAD 83/91 (WASHINGTON STATE PLANE GRID, SOUTH ZONE) N40°14'30"E FROM LEWIS COUNTY STATIC CONTROL POINT NO. 1004 TO LEWIS COUNTY STATIC CONTROL POINT NO. 1001 (BEAVER CREEK JOB) HORIZONTAL CONTROL FOR PROJECT WAS DERIVED FROM RTK OBSERVATIONS USING THE ABOVE CONTROL POINTS FOR BASE CONTROL.
 COMBINED SCALE FACTOR IS 1.000096872. (AT LEWIS COUNTY GPS POINT 1004) TO OBTAIN A GRID COORDINATE DIVIDE THE NORTHING BY THIS SCALE FACTOR AND DIVIDE THE EASTING BY THIS SCALE FACTOR, THIS WILL GIVE YOU A WASHINGTON STATE PLANE GRID COORDINATE.
 FOR INSERTING GEO REFERENCE DATA, TRANSLATE N65°00'46"E-104.48' (CONTROL POINT #1062) TO MATCH OUR GROUND DATA
 THE UNDERGROUND UTILITIES WERE LOCATED AS MARKED OUT ON THE GROUND. THE ORDINARY HIGH WATER MARKS WERE LOCATED AS MARKED IN THE FIELD BY LEWIS COUNTY ENVIRONMENTAL DEPARTMENT.
 THE TOPOGRAPHIC SURVEY WAS STARTED ON MAY 14TH AND ENDED ON MAY 16TH. ELEVATIONS ARE BASED ON NAVD '88

POINT #	EASTING	NORTHING	ELEV	DESCRIPTION
1063	977541.6850	455407.1250	253.424	HTK ON LEFT BANK NEAR STATION 22+50
1072	977734.4190	456104.9180	258.357	MAG NAIL ON EAST SIDE OF ROAD 400 FEET NORTH OF THE SITE
1062	977713.0840	455649.8620	257.324	REBAR ON RIGHT BANK NEAR STATION 20+00



Lewis County
 Department of Public Works
 2025 N. E. KRESKY AVE.
 CHEHALIS WA 98532
 PHONE # (360) 40-1123
 FAX # (360) 740-2719

DESIGNED BY: JJP
 DRAWN BY: TVS
 CHECKED BY: BGW
 DATE: 18 JULY 2017

NO.	DATE	REVISION	BY	APP.

**South Fork Chehalis River at Boistfort Road
 MP 4.152 Bank Protection**

COUNTY MAINTENANCE PROJECT NO: 1705
 SURVEY CONTROL AND OWNERSHIP SHEET

SHEET
2 OF **6**



CALL 48 HOURS BEFORE YOU DIG
 1-800-424-5555
 12787 Gateway Drive S
 Seattle, WA 98168
 Phone: 206-241-6000

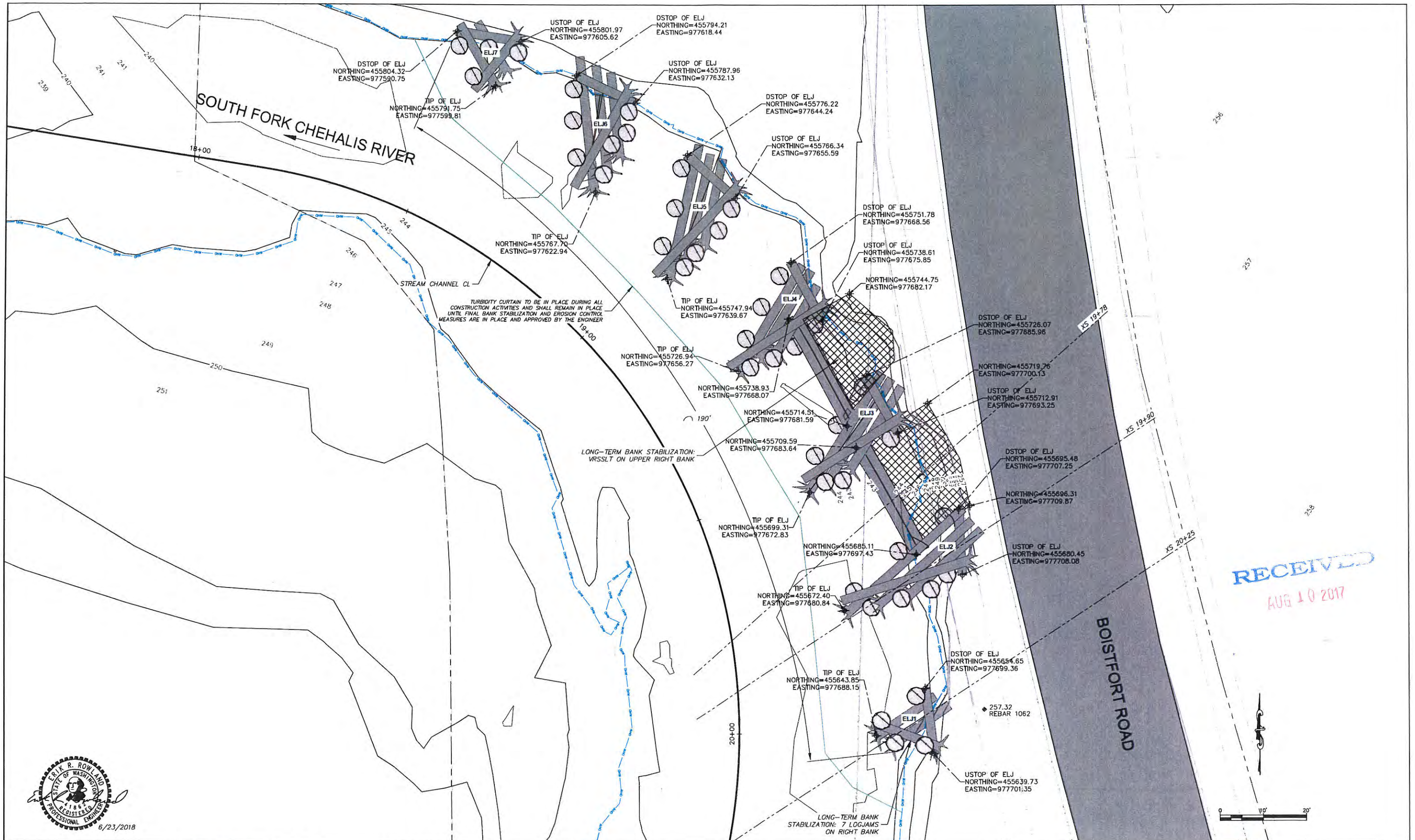

Lewis County
 2025 N. E. KRESKY AVE.
 CHEHALIS WA 98532
 PHONE # (360) 740-1123
 FAX # (360) 740-2719
 Department of Public Works

DESIGNED BY: JJP
 DRAWN BY: TVS
 CHECKED BY: BGW
 DATE: 18 JULY 2017

NO.	DATE	REVISION	BY	APP.

South Fork Chehalis River at Boistfort Road
 MP 4.152 Bank Protection

COUNTY MAINTENANCE PROJECT NO: 1705
 PLAN SHEET

SHEET
 3 OF 6

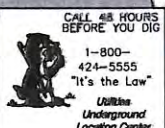

Northwest Hydraulic Consultants
 12787 Gateway Drive S.
 Seattle, WA 98168
 Phone: 206-241-6000

CROSS SECTION 20+25 (LOG JAM #1)

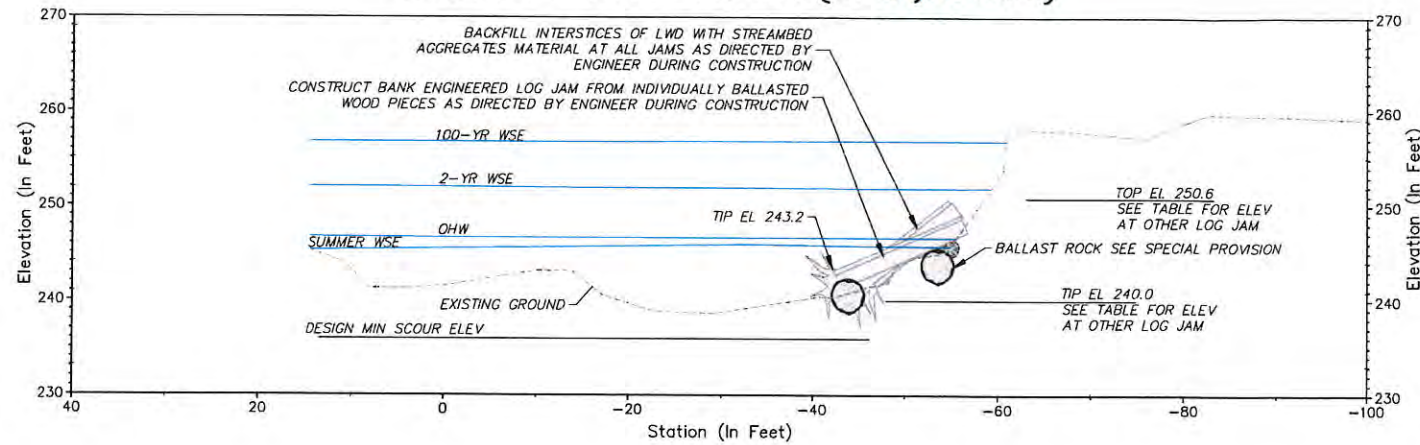

LOG JAM	STA	TIP ELEVATION	TOP ELEVATION	
1	20+25	240.0	250.6	
2	19+90	240.0	253.4	
3	19+70	240.0	254.6	
4	19+33	240.0	255.0	
5	19+12	240.0	253.7	
6	18+92	240.0	254.0	
7	18+67	240.0	251.0	
SOIL WRAP	STA	TOE ELEVATION	BOTTOM OF SOIL WRAP ELEVATION (OHW)	TOP OF SOIL WRAP ELEVATION
BETWEEN LJ 2&3	19+90 TO 19+70	240.0	246.2	254.2
BETWEEN LJ 3&4	19+70 TO 19+33	240.0	246.2	254.2

CROSS SECTION 19+90 (LOG JAM #2)

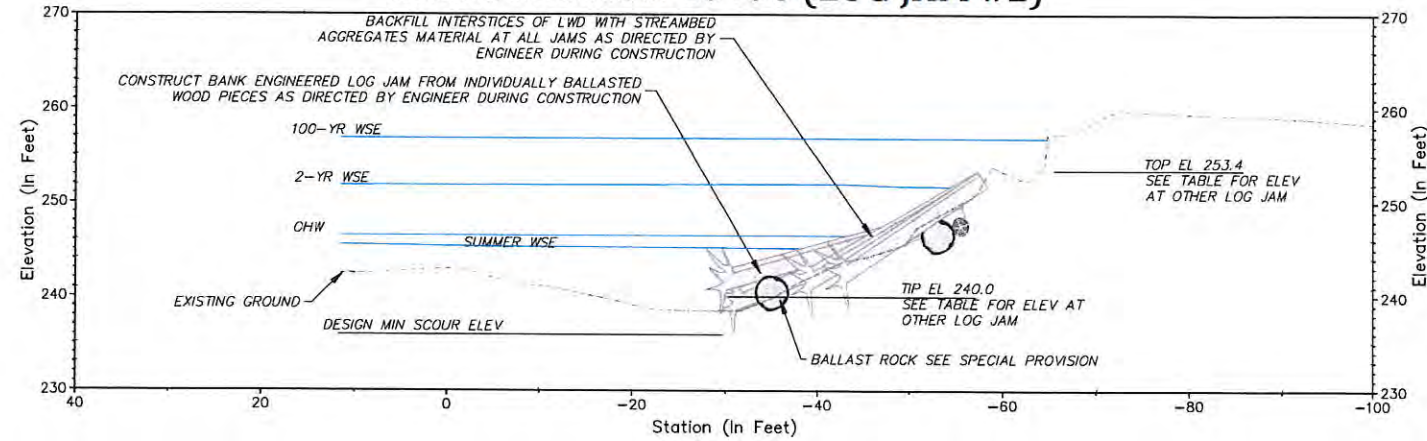

CROSS SECTION 19+78 (SOIL WRAP)

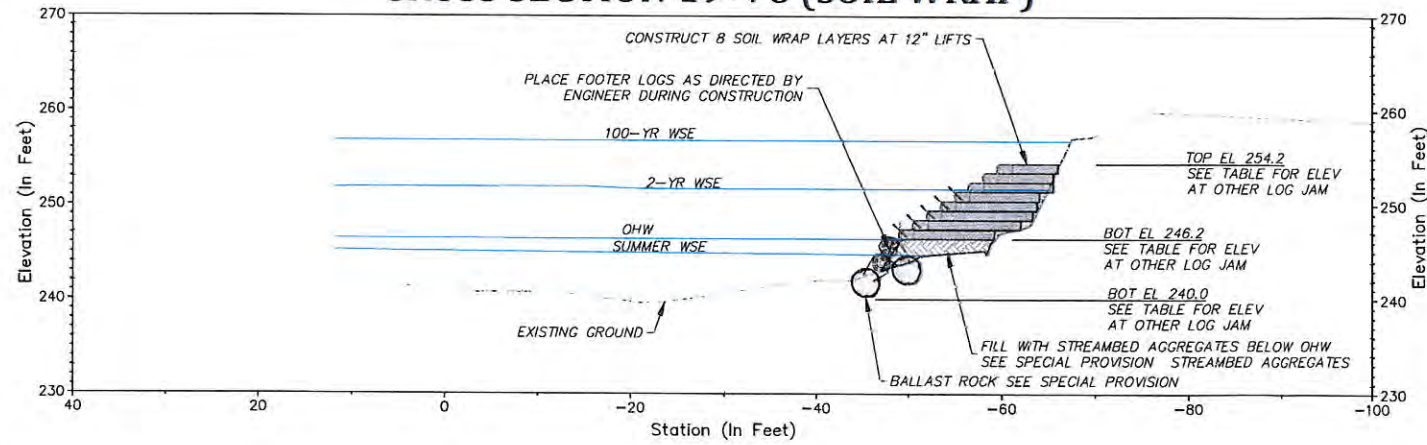

RECEIVED
AUG 10 2017

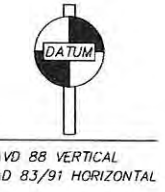
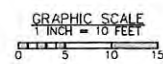

6/23/2018

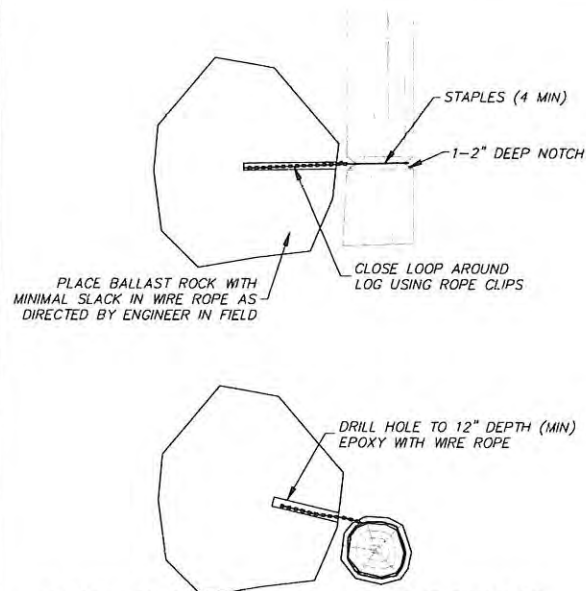

BOULDER TO LWD CONNECTION
SCALE: 1"=2'

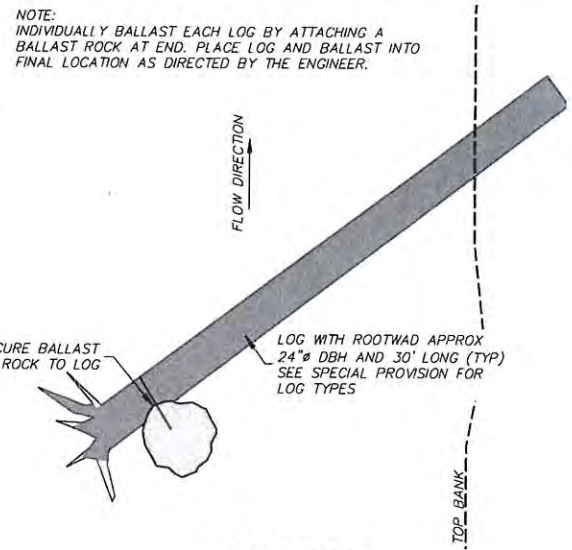

LOG DETAIL
SCALE: 1"=5'

LOG JAMS 2 - 6 MATERIALS:
5 x LOGS WITH ROOTWAD, 24" DBH, 20' LONG (TYPE A)
15 x LOGS WITH ROOTWAD, 24" DBH, 35' LONG (TYPE C)
5 x FOOTER LOGS, 24" DBH, 20' LONG (TYPE B)
35 x 4 MAN BALLAST ROCKS
10 x EARTH ANCHORS

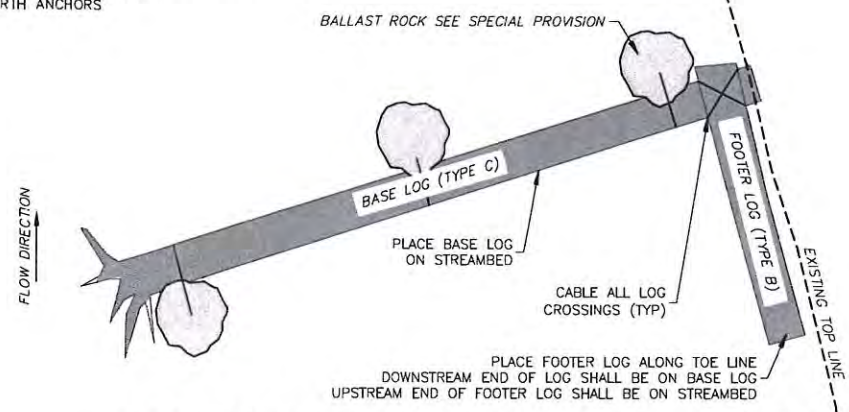

LOG JAM CONSTRUCTION SEQUENCE (STEP 1)
SCALE: NTS

LOG JAMS 1 & 7 MATERIALS:
6 x LOGS WITH ROOTWAD, 24" DBH, 20' LONG (TYPE A)
2 x FOOTER LOGS, 24" DBH, 20' LONG (TYPE B)
8 x 4 MAN BALLAST ROCKS
4 x EARTH ANCHORS

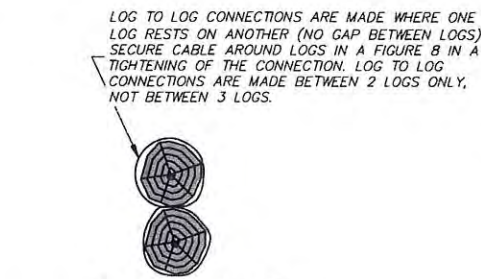
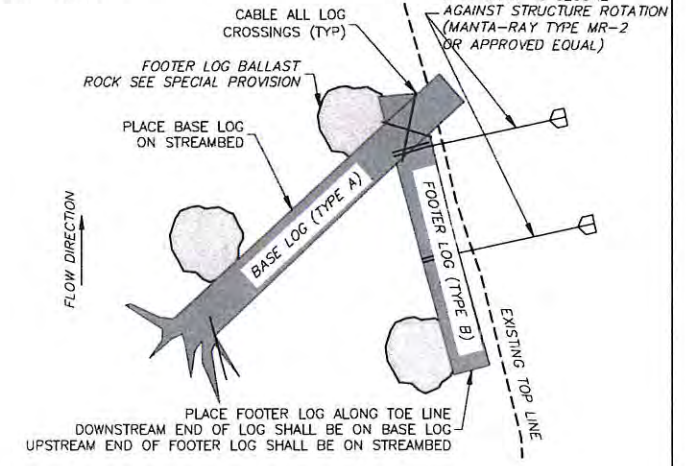

LOG TO LOG CONNECTION DETAIL
SCALE: 1"=5'

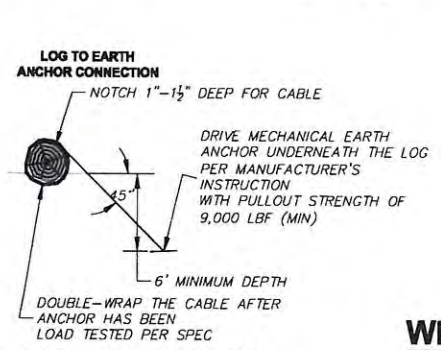

LOG TO EARTH ANCHOR DETAIL
SCALE: 1"=5'

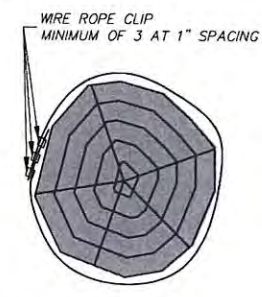

WIRE LOOP DETAIL
SCALE: 1"=1'

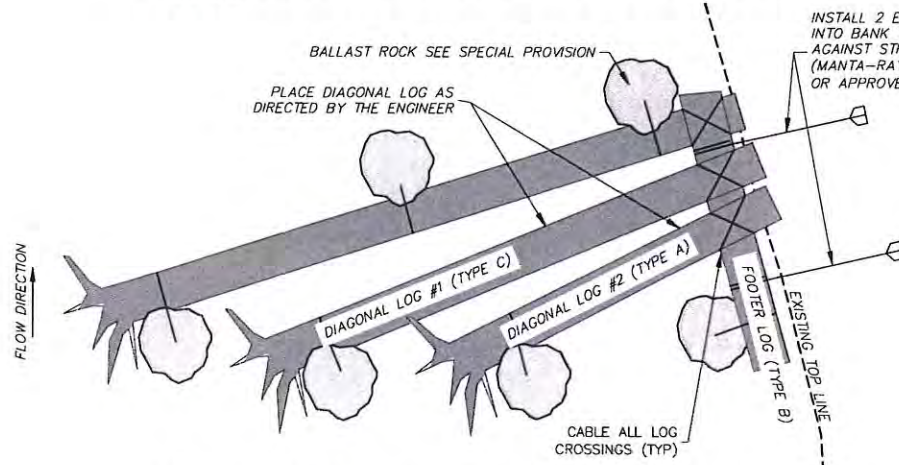

LOG JAM CONSTRUCTION SEQUENCE (STEP 2)
SCALE: NTS

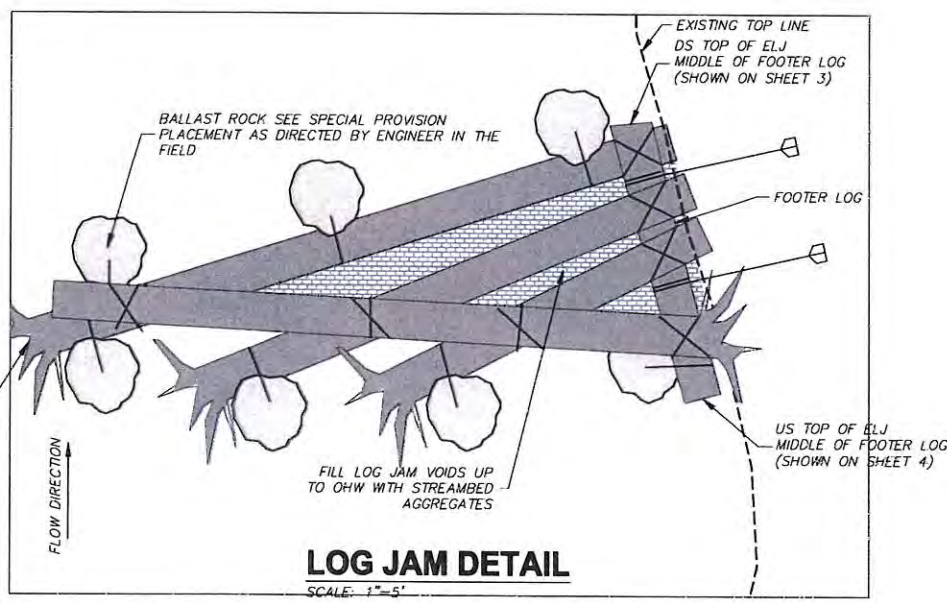
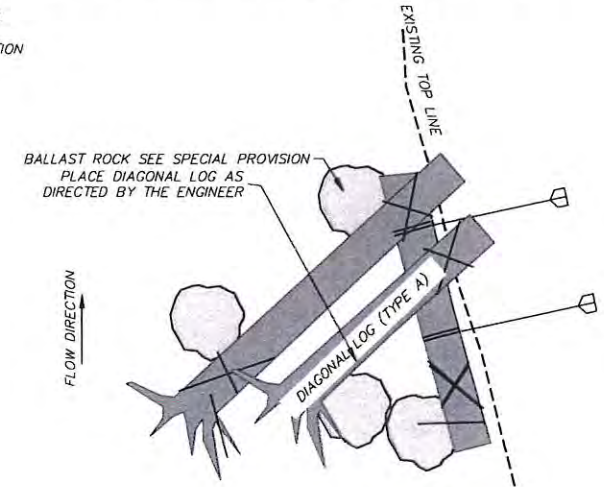

LOG JAM DETAIL
SCALE: 1"=5'

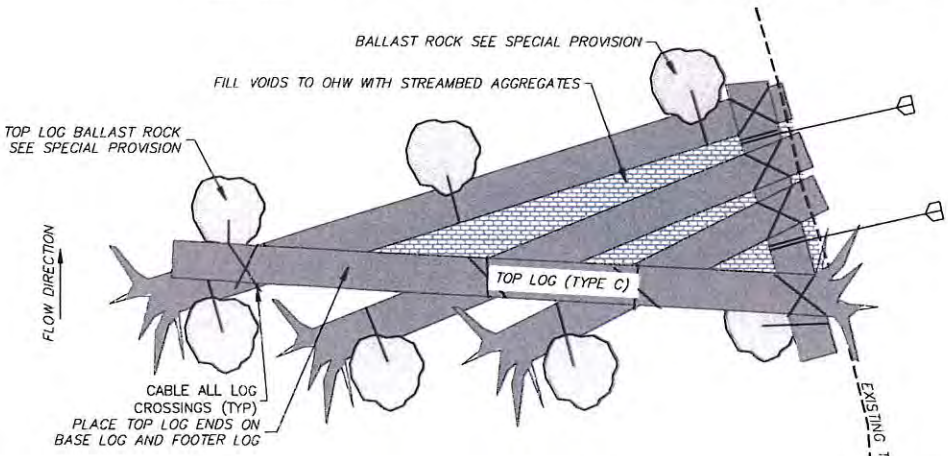

LOG JAM CONSTRUCTION SEQUENCE (STEP 3)
SCALE: NTS

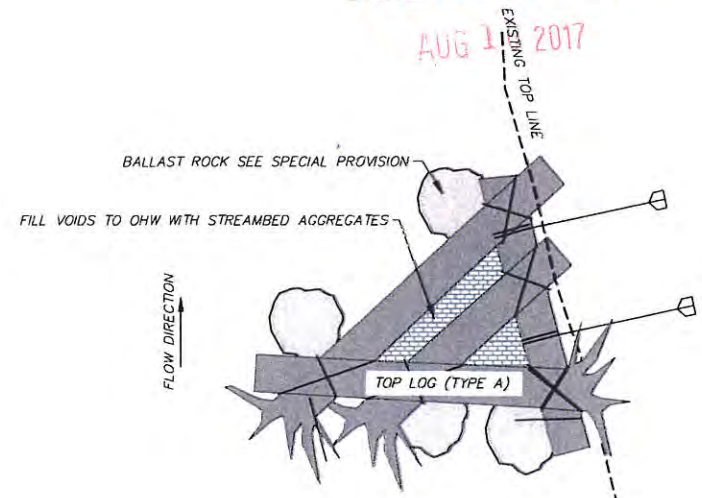

6/23/2018

RECEIVED
AUG 1 2017

	DESIGNED BY: JJP DRAWN BY: TVS CHECKED BY: BGVW DATE: 18 JULY 2017	<table border="1"> <thead> <tr> <th>NO.</th> <th>DATE</th> <th>REVISION</th> <th>BY</th> <th>APP.</th> </tr> </thead> <tbody> <tr> <td> </td> <td> </td> <td> </td> <td> </td> <td> </td> </tr> <tr> <td> </td> <td> </td> <td> </td> <td> </td> <td> </td> </tr> <tr> <td> </td> <td> </td> <td> </td> <td> </td> <td> </td> </tr> </tbody> </table>	NO.	DATE	REVISION	BY	APP.																South Fork Chehalis River at Boistfort Road MP 4.152 Bank Protection
	NO.	DATE	REVISION	BY	APP.																		
2025 N. E. KRESKY AVE. CHEHALIS WA 98532 PHONE # (360) 740-1123 FAX # (360) 740-2719	COUNTY MAINTENANCE PROJECT NO: 1706 LOG JAM DETAILS SHEET	SHEET 5 OF 6	CALL 48 HOURS BEFORE YOU DIG 1-800-424-5555 "It's the Low" Underground Location Center 12787 Gateway Drive S. Seattle, WA 98168 Phone: 206-241-6000																				

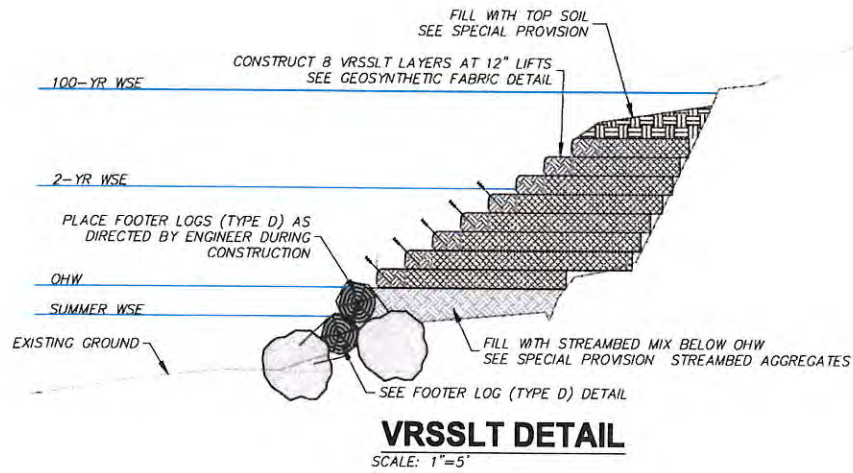

VRSSLT DETAIL
SCALE: 1"=5'

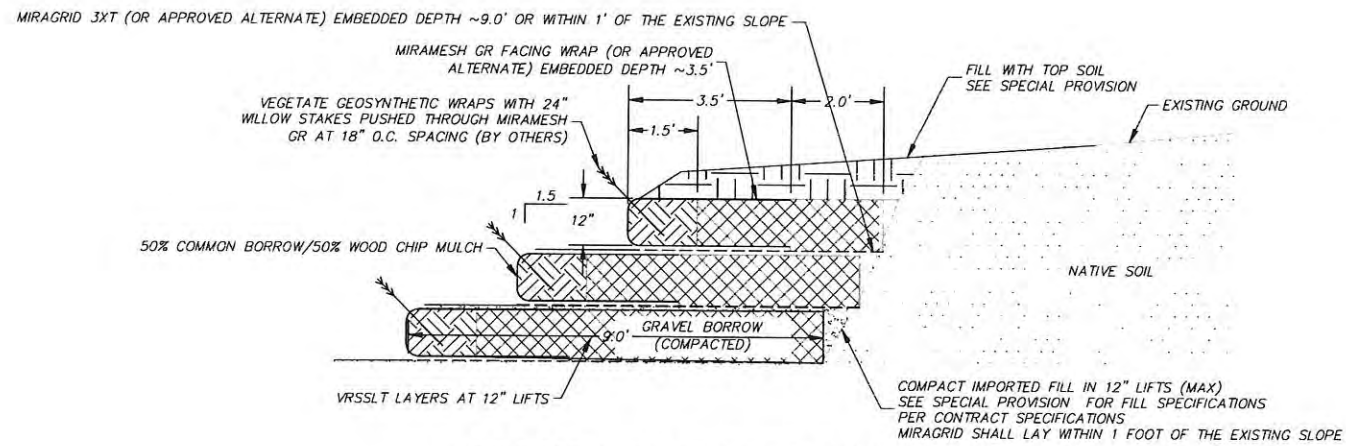

GEOSYNTHETIC FABRIC WRAP SLOPE
SCALE: 1"=2'

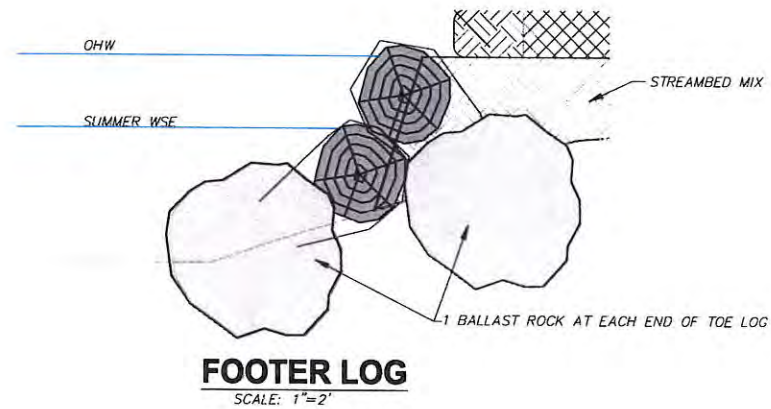

FOOTER LOG
SCALE: 1"=2'

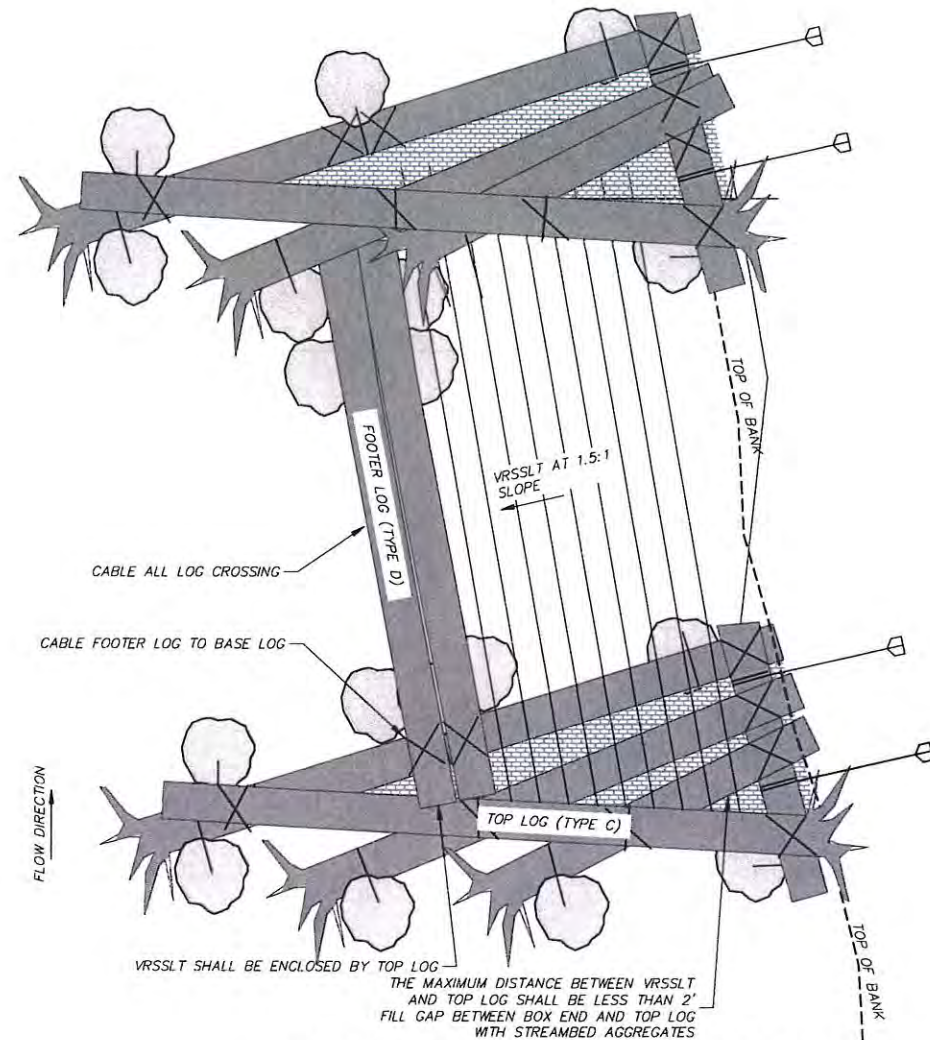

VRSSLT TRANSITION TO LOG JAM
SCALE: 1"=5'

- RECOMMENDED CONSTRUCTION SEQUENCE:
1. CONSTRUCT ALL LOG JAMS FIRST
 2. PLACE IN FOOT LOGS WITH BALLAST ROCKS
 3. FILL AND CREATE LEVEL PAD BEHIND FOOTER LOGS
 4. CONSTRUCT VRSSLT AS DIRECTED BY THE ENGINEER IN FIELD

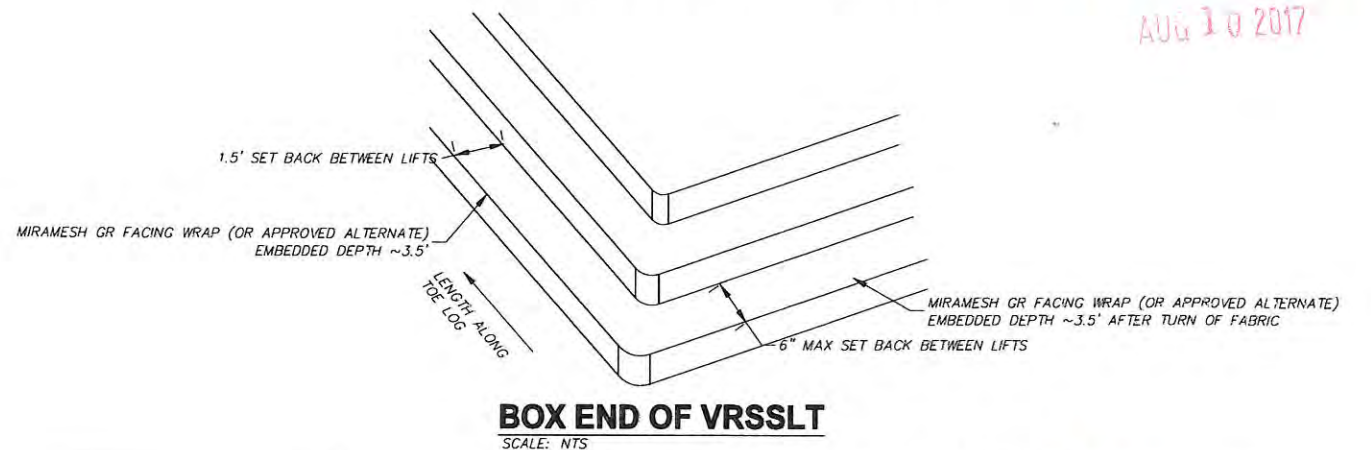

BOX END OF VRSSLT
SCALE: NTS

RECEIVED
AUG 10 2017



6/23/2018

Lewis County
2025 N. E. KRESKY AVE.
CHEHALIS WA 98532
PHONE # (360) 740-1123
FAX # (360) 740-2719

DESIGNED BY: JJP
DRAWN BY: TWS
CHECKED BY: BGW
DATE: 15 JULY 2017

NO.	DATE	REVISION	BY	APP.

South Fork Chehalis River at Boistfort Road
MP 4.152 Bank Protection

COUNTY MAINTENANCE PROJECT NO: 1706
BANK STABILIZATION DETAILS SHEET

SHEET
6
OF
6



CALL 48 HOURS BEFORE YOU DIG
1-800-424-5555
"It's the Law"
Utilizes Underground Location Center
northwest hydrologic consultants
12787 Gateway Drive S.
Seattle, WA 98168
Phone: 206-241-6000

