

REQUEST FOR SEALED BID

1. SCOPE

The purpose of this request for sealed bid is to purchase two precast concrete split-box culverts with wingwalls. The box culvert structures shall support an AASHTO HL-93 loading with a maximum soil bearing pressure of 3,000 pounds per square foot. Precast units shall be connected using weld ties at 6-ft on center maximum or an approved equivalent. Precast concrete split-box culverts include structures 18-ft wide x 10-ft high x 84-ft long (Prairie Crk.) and 14-ft wide x 7-ft high x 52-ft long (Stearns Crk. Trib)., both structures include wingwalls at all four corners per details on pages 4/8 through 8/8.

Two sets of plans for each culvert shall be stamped and certified by a Civil Engineer licensed in the State of Washington. Stamped plans shall be provided to Lewis County within twenty-one working days of contract award. Plans shall include connection details, lifting details, assembly, and installation details. The successful bidder shall provide storage of all bid items for a period of up to fifteen months (if needed) and delivery to the project sites in Lewis County. Lewis County anticipates placing the structures in August 2018. The manufacturer shall coordinate with Lewis County for delivery and material offload (by Lewis County's Contractor) at the project site.

2. NOTES

- For engineering questions, contact Project Engineer Rod Lakey via telephone at (360) 740-2780 or email (Rodney.Lakey@lewiscountywa.gov).
- Lewis County (Agency) reserves the right to ask for descriptive literature and technical specifications at the bidders' expense.
- The bid shall include cost of material as specified and **ALL** shipping to the project sites (Bid Item No. 1 to Pleasant Valley Rd MP 2.176, Napavine, WA and Bid Item No. 2 to Bunker Creek Rd MP 5.678, Adna, WA). No fuel surcharges shall be charged.
- Federal Tax Identification Number from IRS form W-9 is required on all invoices.
- Bidders are to submit a copy of any and all warranties for the proposed product(s) with their response. A copy of the warranties shall also accompany products delivered.
- Manufacturer shall determine concrete wall/top/bottom thickness, split-box culvert dimensions/configuration and wingwall design to achieve interior culvert dimensions and required wingwall limits depicted in the attached Culvert and Wingwall Plans. Plans depict estimated wall thicknesses, footing dimensions, etc. Note, proposed concrete split-box culvert base units shall incorporate interior side heights as depicted to allow placement of streambed material prior to placing top units.
- Culvert dimensions may vary 5% due to manufacturer's existing forms and/or process. The culvert top may be flat or partially arched depending on manufacturer design. The Prairie Creek culvert (Bid Item No. 2) design shall incorporate an attachment method for guardrail via WSDOT Standard Plan C-20.41-01 or an alternate method approved by Lewis County. Guardrail attachments shall be capable of supporting TL-3 (50 MPH speed limit). Lewis County shall provide all guardrail material and installation above the guardrail base plate anchors.

- Due to pending Right of Way negotiations at the various project sites, Lewis County reserves the right to award the entire material bid as listed or alternatively award individual Bid Items.
- All wingwalls shall include 3-inch diameter weep holes at 4-ft on center.

3. SPECIFICATIONS

The Contract shall be in accordance with the Washington State Department of Transportation 2018 Standard Specification for Road, Bridge, and Municipal Construction. All material components shall meet all requirements listed in the Washington State Department of Transportation 2018 Standard Specification for Road, Bridge, and Municipal Construction **Section 6-02 Concrete Structures** (including all applicable reference sections).

See Culvert and Wingwall Plans on Pages 4/8 through 8/8

Precast concrete exterior dimensions and culvert thicknesses are to be determined by the supplier.

4. PUBLIC OPENING OF PROPOSAL

Date and Time of Bid Opening

The Board of County Commissioners of Lewis County or designee, will open sealed proposals and publicly read them aloud on or after 11:00 a.m. on April 24, 2018, at the Lewis County Courthouse, Chehalis, Washington, for the Culvert Material Purchase – CMP 1603 Stearns Crk. Tributary (Pleasant Valley Road MP 2.179) and CMP 1604 Prairie Crk. (Bunker Crk. Rd. MP 5.678) Barrier Removal Projects.

SEALED BIDS MUST BE DELIVERED BY OR BEFORE 11:00 A.M. on Tuesday, April 24, 2018

(Lewis County official time is displayed on Axxess Intertel phones in the office of the Board of County Commissioners. **Bids submitted after 11:00 AM will not be considered for this project.**)

Delivery and Marking of Sealed Bid Proposals

Sealed proposals must be delivered to the Clerk of the Board of Lewis County Commissioners (351 N.W. North Street, Room 210, CMS-01, Chehalis, Washington 98532) by or before **11:00 a.m.** on the date specified for opening, and in an envelope clearly marked: ***“SEALED BID FOR CULVERT MATERIAL PURCHASE – CMP 1603 Stearns Crk. Tributary (Pleasant Valley Road MP 2.179) and CMP 1604 Prairie Crk. (Bunker Crk. Rd. MP 5.678) Barrier Removal Projects, TO BE OPENED ON OR AFTER 11:00 A.M. ON TUESDAY, APRIL 24, 2018.”***

All bid proposals shall be accompanied by a **bid proposal deposit** in cash, certified check, cashier's check or surety bond in an amount **equal to five percent (5%) of the amount of such bid proposal**. Should the successful bidder fail to enter into such contract within the time stated in the specifications, the bid proposal deposit shall be forfeited to the Lewis County Public Works Department.

5. BID SUBMITTALS (Entries shall be typed or entered using an ink pen)

Item	Description	PRICE SHEET		Unit Price	Total Price
		Quantity	Unit		
1	CMP 1603 – Stearns Creek Trib. Pleasant Valley Rd MP 2.179 (Napavine, WA) 14-ft Span by 7-ft High by 52-ft long Precast Concrete Split Box Culvert with Four Wingwalls (as specified) and Delivery.	1	Lump Sum	_____	_____
2	CMP 1604 – Prairie Creek Bunker Creek Rd MP 5.678 (Adna, WA) 18-ft Span by 10-ft High by 84-ft long Precast Concrete Split Box Culvert with Four Wingwalls (as specified) and Delivery.	1	Lump Sum	_____	_____
				SUBTOTAL	_____
				Washington State Sales Tax 7.8%	_____
				TOTAL	_____

6. CONDITIONS

By signature below, the Authorized Official(s) of the company submitting this Proposal do hereby acknowledge that in the event this Proposal is deemed to be the lowest responsive bid, this document shall be construed to be the legal contract for the purchase of the materials specified herein. The successful bidder shall be liable, and hereby agrees to reimburse Lewis County, for any and all costs incurred by Lewis County due to delays in the delivery of any materials specified herein beyond the agreed delivery date as identified in Part 1. The liability for costs due to material delivery delays shall be limited to the total cost of the bid for the materials as contained in this Proposal. Please be apprised that a bid bond shall accompany this proposal in order for this proposal to be valid as per the Call for Bid.

*Receipt is hereby acknowledged of addendum(s) Number(s) 1 _____, 2 _____, 3 _____.

SIGNATURE OF AUTHORIZED OFFICIAL(S)

Proposal Must be Signed

Company Name _____

Address _____

Unified Business Identifier (U.B.I.) No. _____

Telephone # _____

Federal ID No. _____

FOR COUNTY USE ONLY

AWARD RESOLUTION NO. _____

APPROVED: _____
County Engineer

PROFILE VIEW

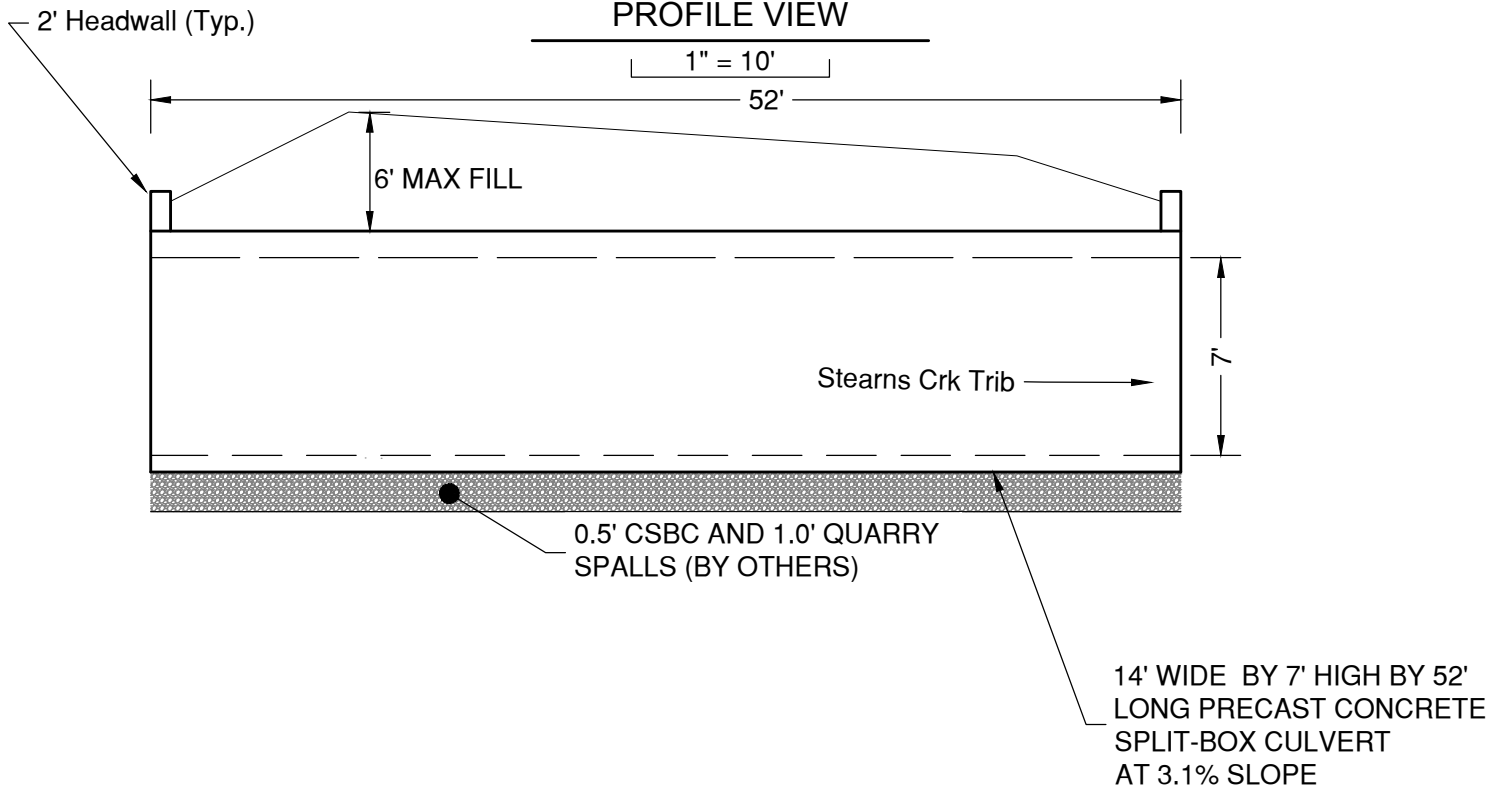

14' WIDE BY 7' HIGH BY 52' LONG PRECAST CONCRETE SPLIT-BOX CULVERT WITH 6-FT MAXIMUM FILL (ARCH TOP ALSO ACCEPTABLE)

SECTION VIEW

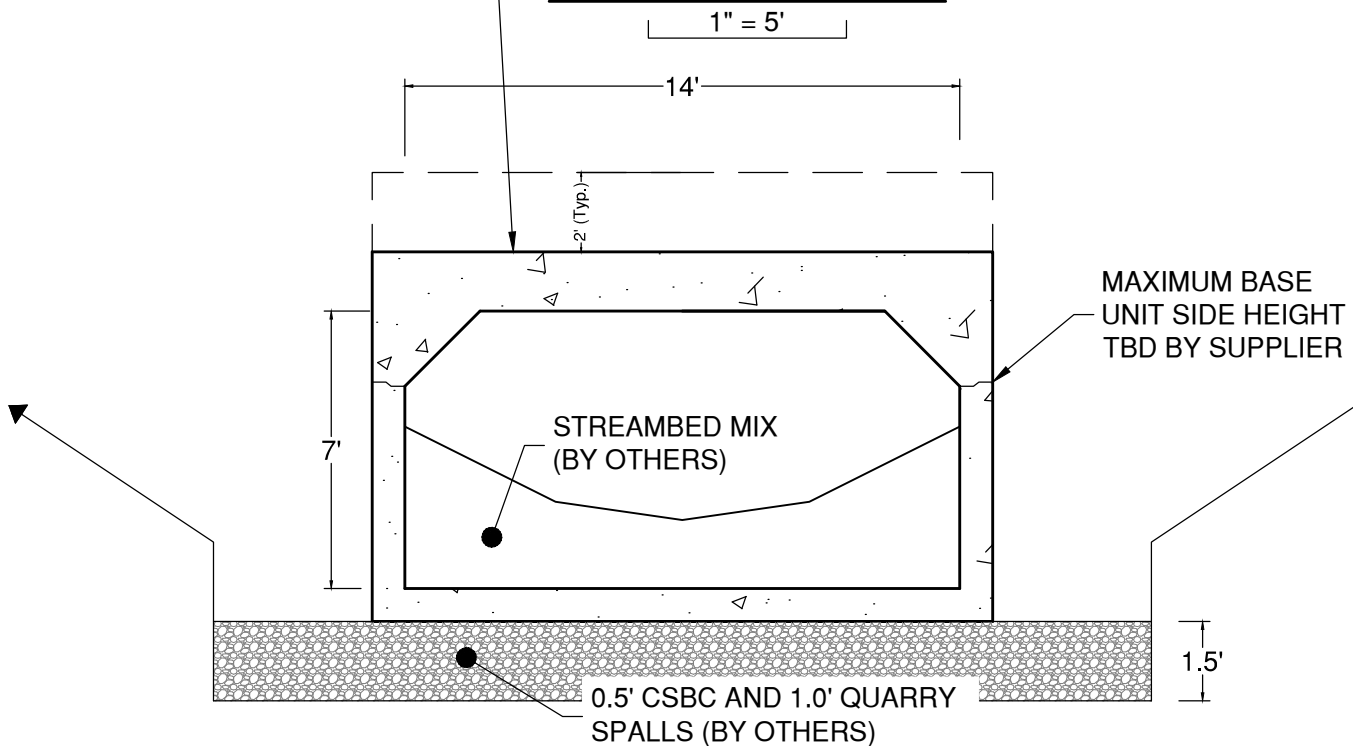

NOTES:

- * CULVERT DIMENSIONS MAY VARY 5% DUE TO MANUFACTURER'S EXISTING FORMS AND/OR PROCESS
- ** DEPTH OF FILL ABOVE CULVERT ±6'

LEWIS COUNTY PUBLIC WORKS
CULVERT MATERIAL PURCHASE

PAGE 4 OF 8
DATE: 04/04/18

BID ITEM NO. 1
CMP 1603 - STEARNS CRK TRIB.
(PLEASANT VALLEY RD MP 2.179)



WINGWALL DETAILS

NOT TO SCALE

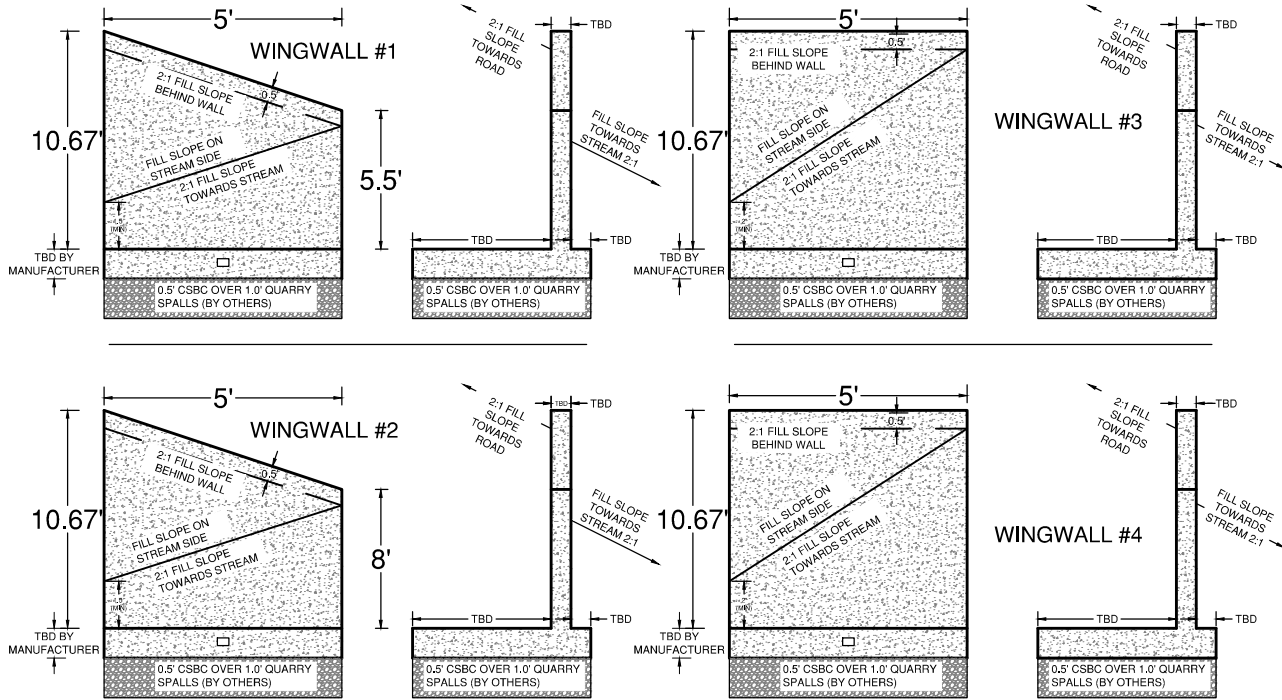

PLAN VIEW

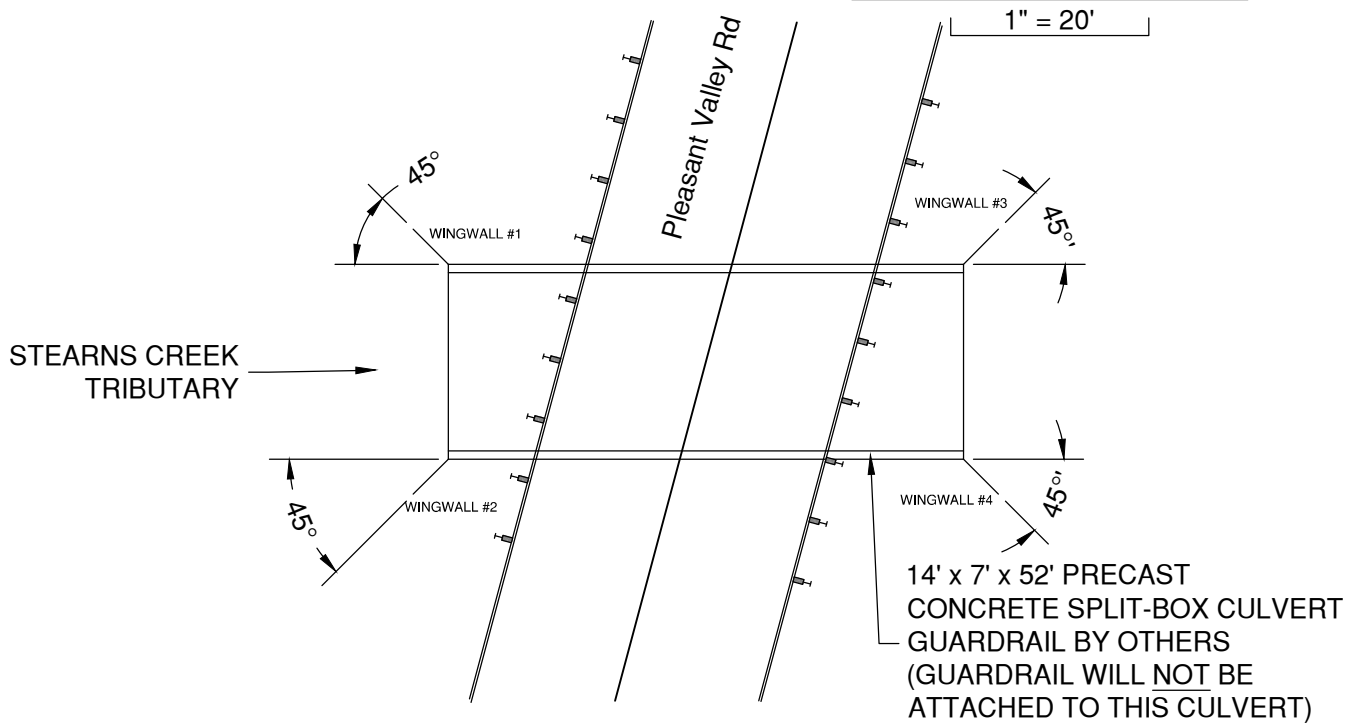

PROFILE VIEW

1" = 20'

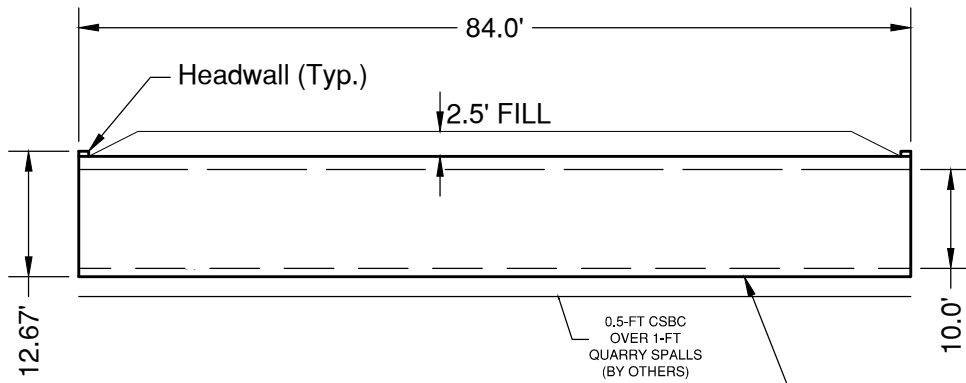

18' WIDE BY 10' HIGH BY 84' LONG PRECAST CONCRETE SPLIT-BOX CULVERT AT 0% SLOPE

18' WIDE BY 10' HIGH BY 84' LONG PRECAST CONCRETE SPLIT-BOX CULVERT WITH 2.5-FT FILL TO ROADWAY CENTERLINE (ARCH TOP ALSO ACCEPTABLE)

SECTION VIEW

1" = 5'

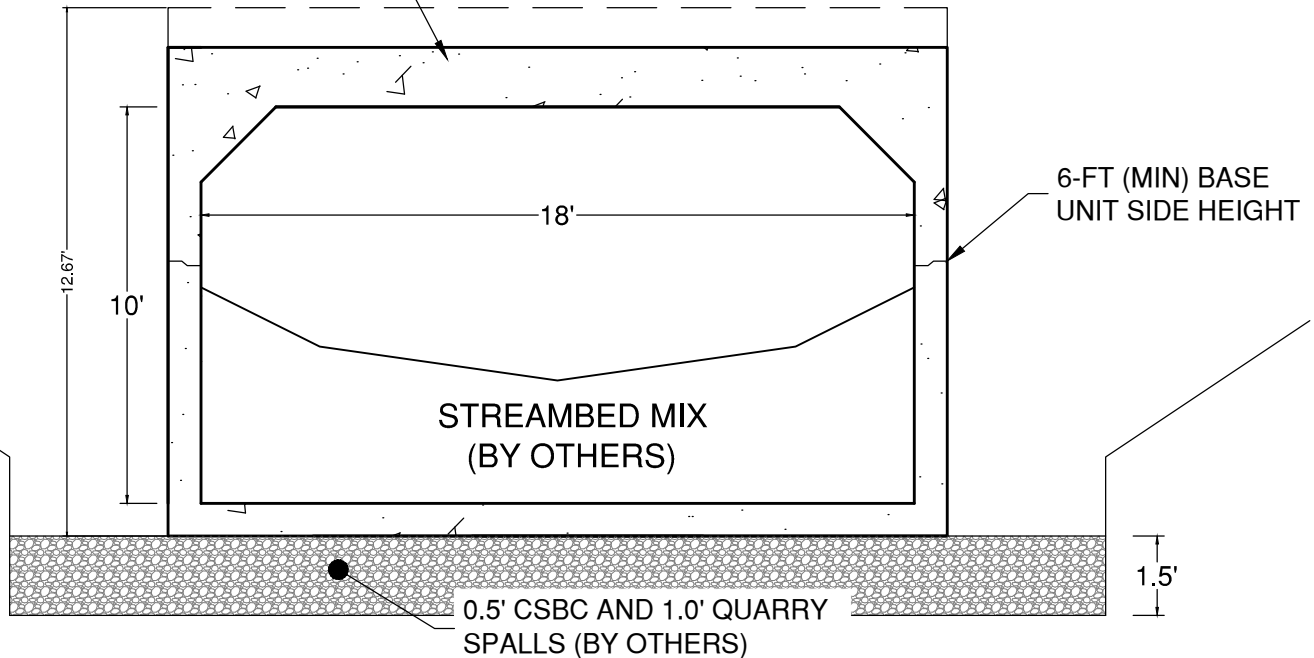

NOTES:

* CULVERT DIMENSIONS MAY VARY 5% DUE TO MANUFACTURER'S EXISTING FORMS AND/OR PROCESS

** DEPTH OF FILL ABOVE CULVERT ±2.5'

LEWIS COUNTY PUBLIC WORKS
CULVERT MATERIAL PURCHASE

PAGE 6 OF 8
DATE: 04/04/18

BID ITEM NO.2
CMP 1604 - PRAIRIE CREEK
BUNKER CREEK RD MP 5.678



WINGWALL DETAILS

NOT TO SCALE

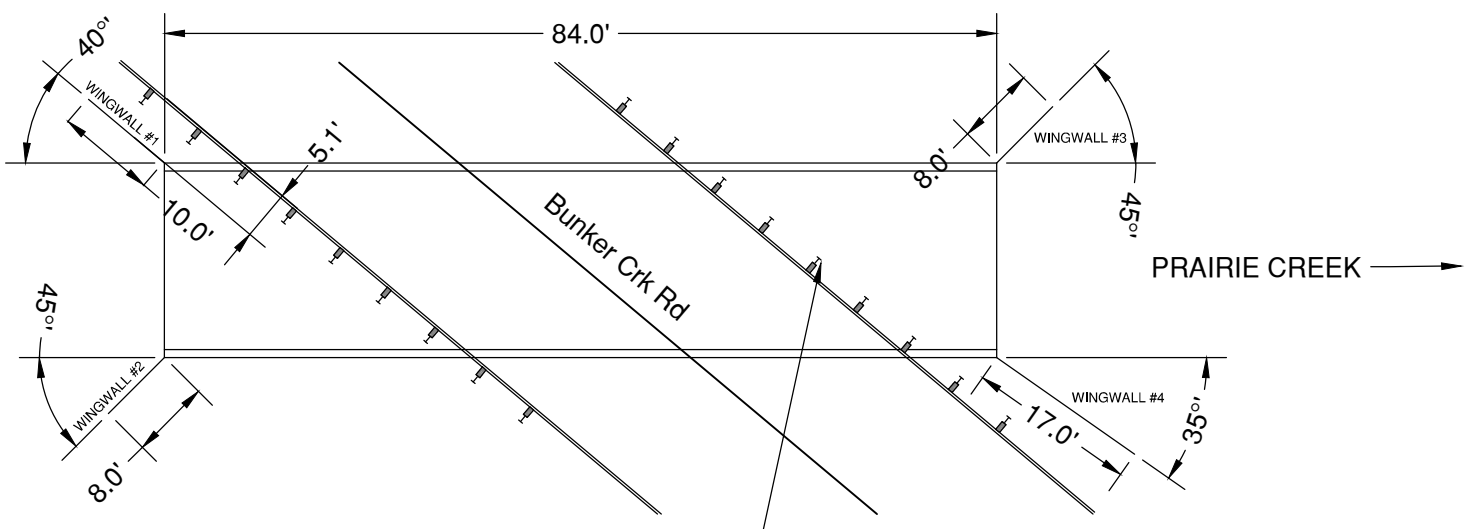
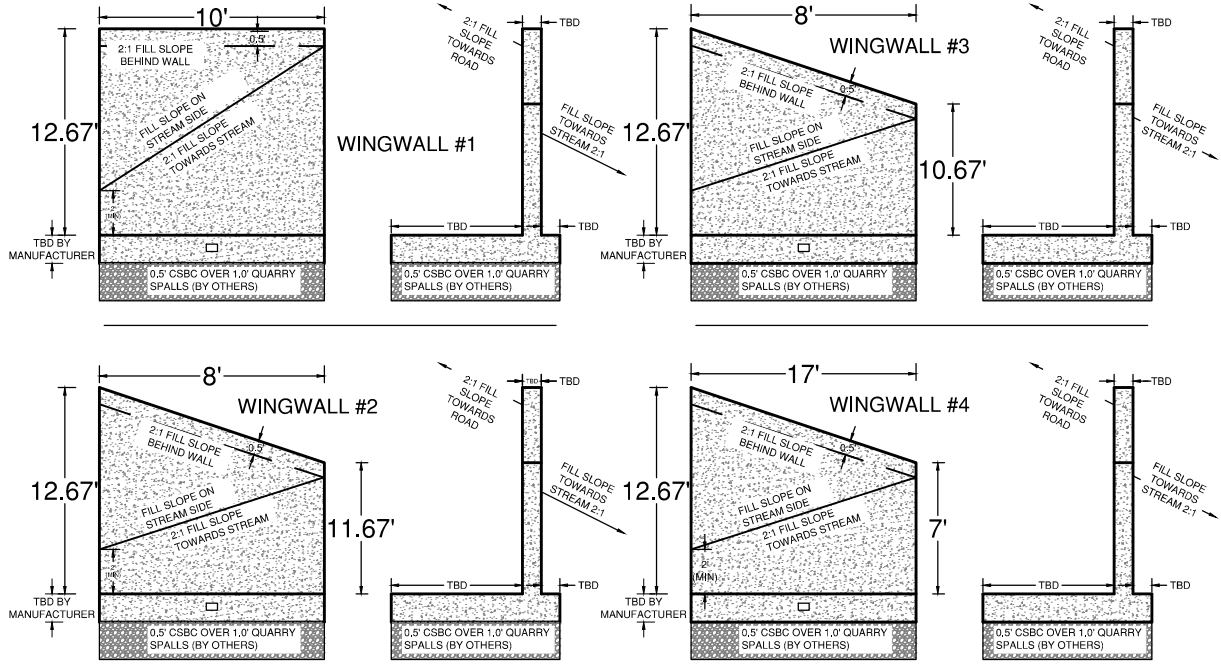

PLAN VIEW

1" = 20'

THE PRECAST 18'X10'X84' CONCRETE SPLIT-BOX CULVERT SHALL BE DESIGNED TO ATTACH GUARDRAIL POSTS PER WSDOT STANDARD PLAN C-20.41-01 OR AN ALTERNATE ATTACHMENT METHOD APPROVED BY LEWIS COUNTY -- 50 MPH POSTED SPEED LIMIT AT THIS SITE (COMPONENTS ABOVE BASE PLATE ANCHORS BY OTHERS)



BID ITEM NO. 2
CMP 1604 - PRAIRIE CREEK
BUNKER CREEK RD MP 5.678
 Adjacent Address: 1246 Bunker
 Creek Road, Adna, WA

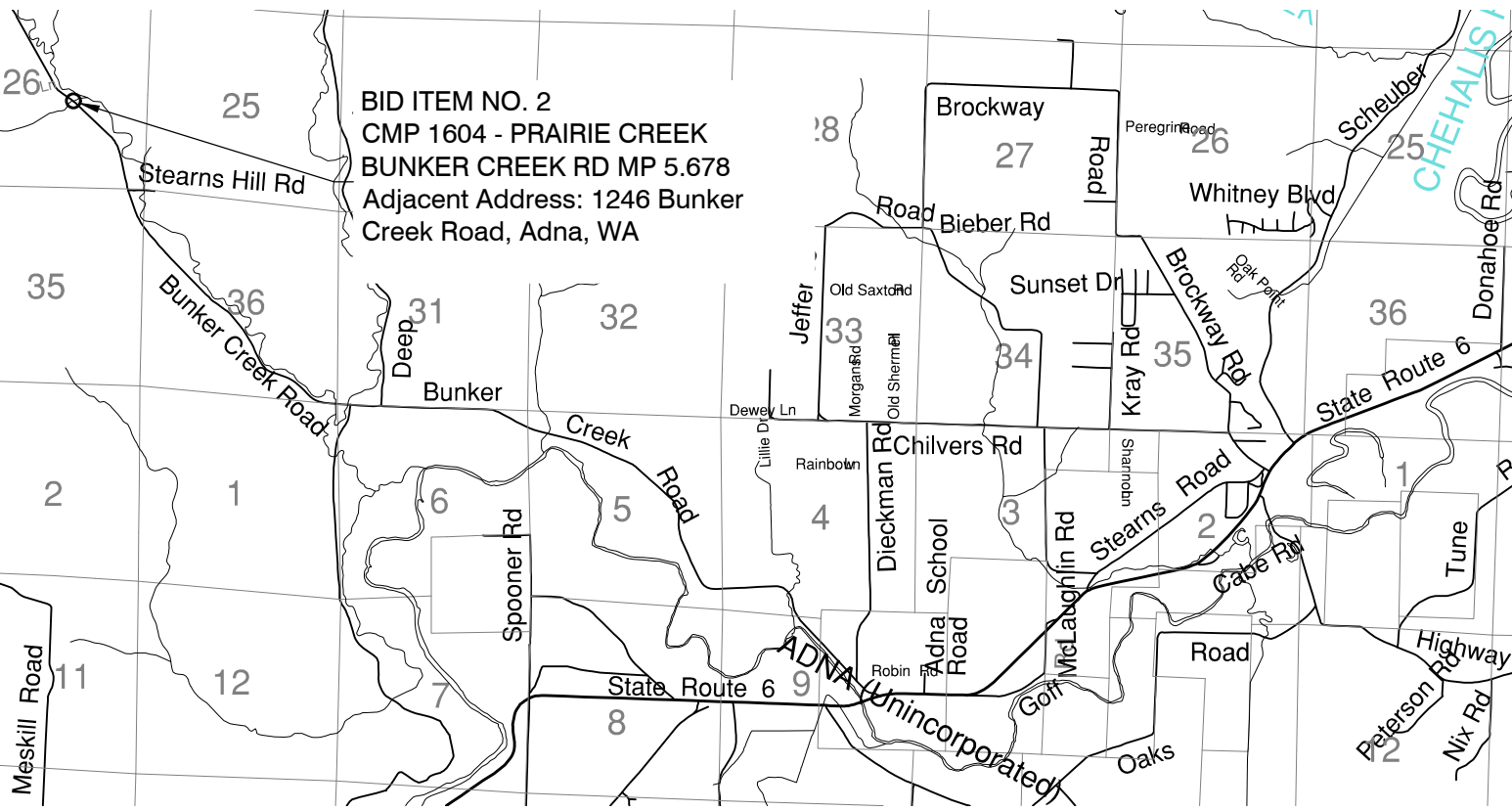

BID ITEM NO. 1
CMP 1603 - STEARNS CRK TRIB.
(PLEASANT VALLEY RD MP 2.179)
 Adjacent Address: 552 Pleasant
 Valley Road, Napavine, WA

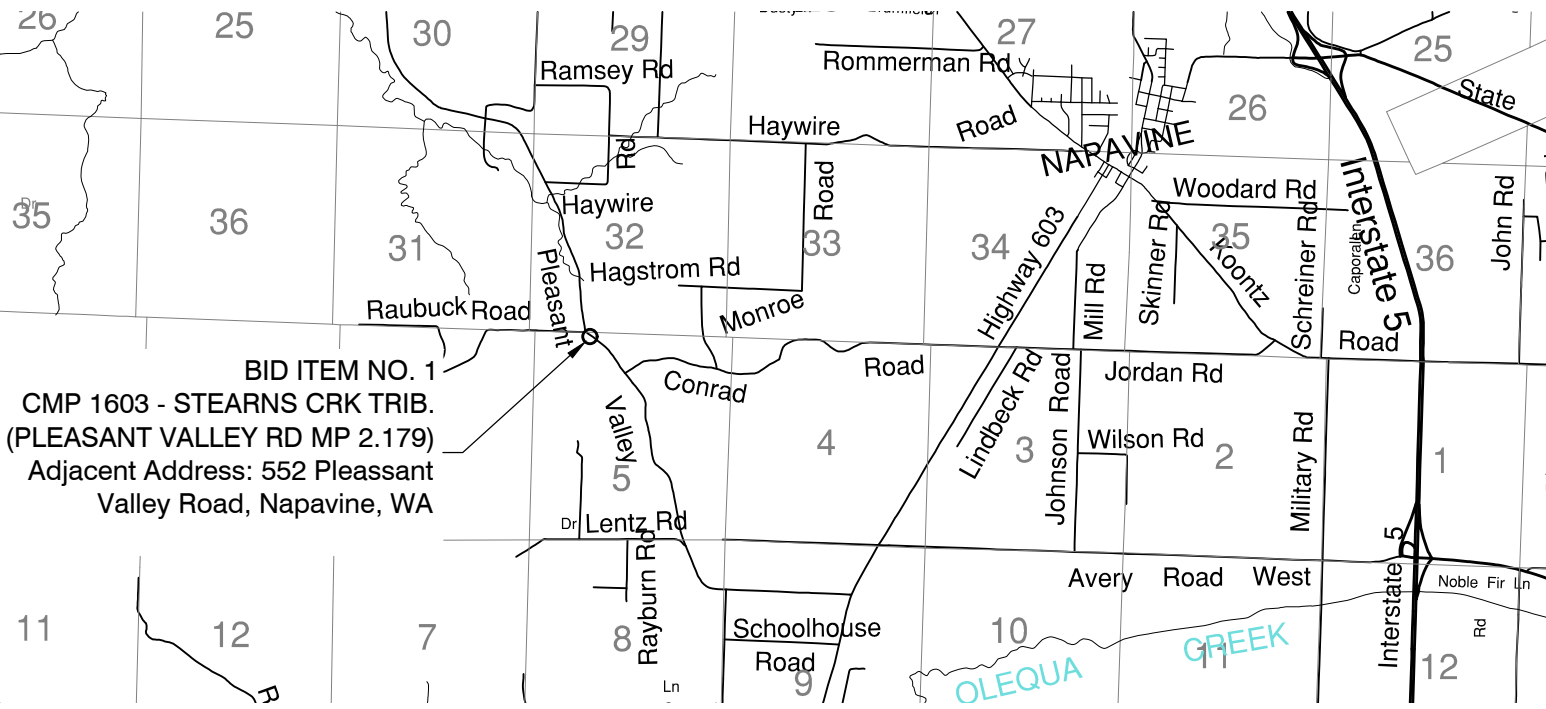

LEWIS COUNTY PUBLIC WORKS **PAGE 8 OF 8**
CULVERT MATERIAL PURCHASE **DATE: 04/04/18**

VICINITY MAP
 1" = 1 Mile