

Lewis County
Department of Public Works
Engineering Division

**CONTRACT
PROVISIONS AND PLANS
FOR CONSTRUCTION OF:**
***INTERSTATE AVENUE
PAVING PROJECT***

**FEDERAL AID PROJECT NO. STPUS-HIPUS-5686(001)
F.A. Contract No. TA-6614
COUNTY ROAD PROJECT NO. 2187D
July, 2019
BOOK 2 OF 2**

Lewis County Public Works
2025 NE Kresky Ave.
Chehalis, WA 98532-2626



BOARD OF COUNTY COMMISSIONERS

Edna Fund, District No. 1
Robert C. Jackson, District No. 2
Gary Stamper, District No. 3

APPENDIX A

WASHINGTON STATE PREVAILING WAGE RATES

INCLUDING:

State Wage Rates

Wage Rate Supplements

Wage Rate Benefit Codes

Federal Wage Rates

State of Washington
Department of Labor & Industries
Prevailing Wage Section - Telephone 360-902-5335
PO Box 44540, Olympia, WA 98504-4540

Washington State Prevailing Wage

The PREVAILING WAGES listed here include both the hourly wage rate and the hourly rate of fringe benefits. On public works projects, worker's wage and benefit rates must add to not less than this total. A brief description of overtime calculation requirements are provided on the Benefit Code Key.

Journey Level Prevailing Wage Rates for the Effective Date: 7/3/2019

| <u>County</u> | <u>Trade</u> | <u>Job Classification</u> | <u>Wage</u> | <u>Holiday</u> | <u>Overtime</u> | <u>Note</u> | <u>*Risk Class</u> |
|---------------|--|---|-------------|----------------|-----------------|-------------|----------------------|
| Lewis | Asbestos Abatement Workers | Journey Level | \$46.57 | <u>5D</u> | <u>1H</u> | | View |
| Lewis | Boilermakers | Journey Level | \$66.54 | <u>5N</u> | <u>1C</u> | | View |
| Lewis | Brick Mason | Journey Level | \$57.32 | <u>5A</u> | <u>1M</u> | | View |
| Lewis | Brick Mason | Pointer-Caulker-Cleaner | \$57.32 | <u>5A</u> | <u>1M</u> | | View |
| Lewis | Building Service Employees | Janitor | \$12.00 | | <u>1</u> | | View |
| Lewis | Building Service Employees | Shampooer | \$12.00 | | <u>1</u> | | View |
| Lewis | Building Service Employees | Waxer | \$12.00 | | <u>1</u> | | View |
| Lewis | Building Service Employees | Window Cleaner | \$13.22 | | <u>1</u> | | View |
| Lewis | Cabinet Makers (In Shop) | Journey Level | \$23.17 | | <u>1</u> | | View |
| Lewis | Carpenters | Acoustical Worker | \$60.04 | <u>5D</u> | <u>4C</u> | | View |
| Lewis | Carpenters | Bridge, Dock And Wharf Carpenters | \$60.04 | <u>5D</u> | <u>4C</u> | | View |
| Lewis | Carpenters | Carpenter | \$60.04 | <u>5D</u> | <u>4C</u> | | View |
| Lewis | Carpenters | Carpenters on Stationary Tools | \$60.17 | <u>5D</u> | <u>4C</u> | | View |
| Lewis | Carpenters | Creosoted Material | \$60.14 | <u>5D</u> | <u>4C</u> | | View |
| Lewis | Carpenters | Floor Finisher | \$60.04 | <u>5D</u> | <u>4C</u> | | View |
| Lewis | Carpenters | Floor Layer | \$60.04 | <u>5D</u> | <u>4C</u> | | View |
| Lewis | Carpenters | Scaffold Erector | \$60.04 | <u>5D</u> | <u>4C</u> | | View |
| Lewis | Cement Masons | Journey Level | \$60.07 | <u>7A</u> | <u>4U</u> | | View |
| Lewis | Divers & Tenders | Bell/Vehicle or Submersible Operator (Not Under Pressure) | \$113.60 | <u>5D</u> | <u>4C</u> | | View |
| Lewis | Divers & Tenders | Dive Supervisor/Master | \$76.33 | <u>5D</u> | <u>4C</u> | | View |
| Lewis | Divers & Tenders | Diver | \$113.60 | <u>5D</u> | <u>4C</u> | <u>8V</u> | View |
| Lewis | Divers & Tenders | Diver On Standby | \$71.33 | <u>5D</u> | <u>4C</u> | | View |
| Lewis | Divers & Tenders | Diver Tender | \$64.71 | <u>5D</u> | <u>4C</u> | | View |
| Lewis | Divers & Tenders | Manifold Operator | \$64.71 | <u>5D</u> | <u>4C</u> | | View |

| | | | | | | | |
|-------|--|---|----------|--------------------|--------------------|--------------------|----------------------|
| Lewis | Divers & Tenders | Manifold Operator Mixed Gas | \$69.71 | 5D | 4C | | View |
| Lewis | Divers & Tenders | Remote Operated Vehicle Operator/Technician | \$64.71 | 5D | 4C | | View |
| Lewis | Divers & Tenders | Remote Operated Vehicle Tender | \$60.29 | 5A | 4C | | View |
| Lewis | Dredge Workers | Assistant Engineer | \$56.44 | 5D | 3F | | View |
| Lewis | Dredge Workers | Assistant Mate (Deckhand) | \$56.00 | 5D | 3F | | View |
| Lewis | Dredge Workers | Boatmen | \$56.44 | 5D | 3F | | View |
| Lewis | Dredge Workers | Engineer Welder | \$57.51 | 5D | 3F | | View |
| Lewis | Dredge Workers | Leverman, Hydraulic | \$58.67 | 5D | 3F | | View |
| Lewis | Dredge Workers | Mates | \$56.44 | 5D | 3F | | View |
| Lewis | Dredge Workers | Oiler | \$56.00 | 5D | 3F | | View |
| Lewis | Drywall Applicator | Journey Level | \$58.48 | 5D | 1H | | View |
| Lewis | Drywall Tapers | Journey Level | \$59.32 | 5P | 1E | | View |
| Lewis | Electrical Fixture Maintenance Workers | Journey Level | \$12.00 | | 1 | | View |
| Lewis | Electricians - Inside | Cable Splicer | \$71.81 | 5C | 1G | | View |
| Lewis | Electricians - Inside | Journey Level | \$67.31 | 5C | 1G | | View |
| Lewis | Electricians - Inside | Lead Covered Cable Splicer | \$76.31 | 5C | 1G | | View |
| Lewis | Electricians - Inside | Welder | \$71.81 | 5C | 1G | | View |
| Lewis | Electricians - Motor Shop | Craftsman | \$15.37 | | 1 | | View |
| Lewis | Electricians - Motor Shop | Journey Level | \$14.69 | | 1 | | View |
| Lewis | Electricians - Powerline Construction | Cable Splicer | \$79.60 | 5A | 4D | | View |
| Lewis | Electricians - Powerline Construction | Certified Line Welder | \$72.98 | 5A | 4D | | View |
| Lewis | Electricians - Powerline Construction | Groundperson | \$47.94 | 5A | 4D | | View |
| Lewis | Electricians - Powerline Construction | Heavy Line Equipment Operator | \$72.98 | 5A | 4D | | View |
| Lewis | Electricians - Powerline Construction | Journey Level Lineperson | \$72.98 | 5A | 4D | | View |
| Lewis | Electricians - Powerline Construction | Line Equipment Operator | \$62.06 | 5A | 4D | | View |
| Lewis | Electricians - Powerline Construction | Meter Installer | \$47.94 | 5A | 4D | 8W | View |
| Lewis | Electricians - Powerline Construction | Pole Sprayer | \$72.98 | 5A | 4D | | View |
| Lewis | Electricians - Powerline Construction | Powderperson | \$54.55 | 5A | 4D | | View |
| Lewis | Electronic Technicians | Journey Level | \$43.19 | 6Z | 1B | | View |
| Lewis | Elevator Constructors | Mechanic | \$94.22 | 7D | 4A | | View |
| Lewis | Elevator Constructors | Mechanic In Charge | \$101.73 | 7D | 4A | | View |
| Lewis | Fabricated Precast Concrete Products | Journey Level | \$13.50 | | 1 | | View |
| Lewis | Fabricated Precast Concrete Products | Journey Level - In-Factory Work Only | \$13.50 | | 1 | | View |

| | | | | | | |
|-------|--|---------------------------------------|---------|--------------------|--------------------|----------------------|
| Lewis | Fence Erectors | Fence Erector | \$41.45 | 7A | 3I | View |
| Lewis | Fence Erectors | Fence Laborer | \$41.45 | 7A | 3I | View |
| Lewis | Flaggers | Journey Level | \$41.45 | 7A | 3I | View |
| Lewis | Glaziers | Journey Level | \$64.56 | 7L | 1Y | View |
| Lewis | Heat & Frost Insulators And Asbestos Workers | Journeyman | \$73.58 | 5J | 4H | View |
| Lewis | Heating Equipment Mechanics | Journey Level | \$82.51 | 7F | 1E | View |
| Lewis | Hod Carriers & Mason Tenders | Journey Level | \$50.42 | 7A | 3I | View |
| Lewis | Industrial Power Vacuum Cleaner | Journey Level | \$12.00 | | 1 | View |
| Lewis | Inland Boatmen | Boat Operator | \$61.41 | 5B | 1K | View |
| Lewis | Inland Boatmen | Cook | \$56.48 | 5B | 1K | View |
| Lewis | Inland Boatmen | Deckhand | \$57.48 | 5B | 1K | View |
| Lewis | Inland Boatmen | Deckhand Engineer | \$58.81 | 5B | 1K | View |
| Lewis | Inland Boatmen | Launch Operator | \$58.89 | 5B | 1K | View |
| Lewis | Inland Boatmen | Mate | \$57.31 | 5B | 1K | View |
| Lewis | Inspection/Cleaning/Sealing Of Sewer & Water Systems By Remote Control | Cleaner Operator, Foamer Operator | \$12.00 | | 1 | View |
| Lewis | Inspection/Cleaning/Sealing Of Sewer & Water Systems By Remote Control | Grout Truck Operator | \$12.00 | | 1 | View |
| Lewis | Inspection/Cleaning/Sealing Of Sewer & Water Systems By Remote Control | Head Operator | \$12.78 | | 1 | View |
| Lewis | Inspection/Cleaning/Sealing Of Sewer & Water Systems By Remote Control | Technician | \$12.00 | | 1 | View |
| Lewis | Inspection/Cleaning/Sealing Of Sewer & Water Systems By Remote Control | Tv Truck Operator | \$12.00 | | 1 | View |
| Lewis | Insulation Applicators | Journey Level | \$60.04 | 5D | 4C | View |
| Lewis | Ironworkers | Journeyman | \$70.68 | 7N | 1O | View |
| Lewis | Laborers | Air, Gas Or Electric Vibrating Screed | \$48.90 | 7A | 3I | View |
| Lewis | Laborers | Airtrac Drill Operator | \$50.42 | 7A | 3I | View |
| Lewis | Laborers | Ballast Regular Machine | \$48.90 | 7A | 3I | View |
| Lewis | Laborers | Batch Weighman | \$41.45 | 7A | 3I | View |
| Lewis | Laborers | Brick Pavers | \$48.90 | 7A | 3I | View |
| Lewis | Laborers | Brush Cutter | \$48.90 | 7A | 3I | View |
| Lewis | Laborers | Brush Hog Feeder | \$48.90 | 7A | 3I | View |
| Lewis | Laborers | Burner | \$48.90 | 7A | 3I | View |
| Lewis | Laborers | Caisson Worker | \$50.42 | 7A | 3I | View |
| Lewis | Laborers | Carpenter Tender | \$48.90 | 7A | 3I | View |
| Lewis | Laborers | Caulker | \$48.90 | 7A | 3I | View |
| Lewis | Laborers | Cement Dumper-paving | \$49.81 | 7A | 3I | View |
| Lewis | Laborers | Cement Finisher Tender | \$48.90 | 7A | 3I | View |
| Lewis | Laborers | Change House Or Dry | \$48.90 | 7A | 3I | View |

| | | | | | | |
|-------|--------------------------|--|---------|--------------------|--------------------|----------------------|
| | | Shack | | | | |
| Lewis | Laborers | Chipping Gun (under 30 Lbs.) | \$48.90 | 7A | 3I | View |
| Lewis | Laborers | Chipping Gun(30 Lbs. And Over) | \$49.81 | 7A | 3I | View |
| Lewis | Laborers | Choker Setter | \$48.90 | 7A | 3I | View |
| Lewis | Laborers | Chuck Tender | \$48.90 | 7A | 3I | View |
| Lewis | Laborers | Clary Power Spreader | \$49.81 | 7A | 3I | View |
| Lewis | Laborers | Clean-up Laborer | \$48.90 | 7A | 3I | View |
| Lewis | Laborers | Concrete Dumper/chute Operator | \$49.81 | 7A | 3I | View |
| Lewis | Laborers | Concrete Form Stripper | \$48.90 | 7A | 3I | View |
| Lewis | Laborers | Concrete Placement Crew | \$49.81 | 7A | 3I | View |
| Lewis | Laborers | Concrete Saw Operator/core Driller | \$49.81 | 7A | 3I | View |
| Lewis | Laborers | Crusher Feeder | \$41.45 | 7A | 3I | View |
| Lewis | Laborers | Curing Laborer | \$48.90 | 7A | 3I | View |
| Lewis | Laborers | Demolition: Wrecking & Moving (incl. Charred Material) | \$48.90 | 7A | 3I | View |
| Lewis | Laborers | Ditch Digger | \$48.90 | 7A | 3I | View |
| Lewis | Laborers | Diver | \$50.42 | 7A | 3I | View |
| Lewis | Laborers | Drill Operator (hydraulic,diamond) | \$49.81 | 7A | 3I | View |
| Lewis | Laborers | Dry Stack Walls | \$48.90 | 7A | 3I | View |
| Lewis | Laborers | Dump Person | \$48.90 | 7A | 3I | View |
| Lewis | Laborers | Epoxy Technician | \$48.90 | 7A | 3I | View |
| Lewis | Laborers | Erosion Control Worker | \$48.90 | 7A | 3I | View |
| Lewis | Laborers | Faller & Bucker Chain Saw | \$49.81 | 7A | 3I | View |
| Lewis | Laborers | Fine Graders | \$48.90 | 7A | 3I | View |
| Lewis | Laborers | Firewatch | \$41.45 | 7A | 3I | View |
| Lewis | Laborers | Form Setter | \$48.90 | 7A | 3I | View |
| Lewis | Laborers | Gabian Basket Builders | \$48.90 | 7A | 3I | View |
| Lewis | Laborers | General Laborer | \$48.90 | 7A | 3I | View |
| Lewis | Laborers | Grade Checker & Transit Person | \$50.42 | 7A | 3I | View |
| Lewis | Laborers | Grinders | \$48.90 | 7A | 3I | View |
| Lewis | Laborers | Grout Machine Tender | \$48.90 | 7A | 3I | View |
| Lewis | Laborers | Groutmen (pressure)including Post Tension Beams | \$49.81 | 7A | 3I | View |
| Lewis | Laborers | Guardrail Erector | \$48.90 | 7A | 3I | View |
| Lewis | Laborers | Hazardous Waste Worker (level A) | \$50.42 | 7A | 3I | View |
| Lewis | Laborers | Hazardous Waste Worker (level B) | \$49.81 | 7A | 3I | View |
| Lewis | Laborers | Hazardous Waste Worker (level C) | \$48.90 | 7A | 3I | View |

| | | | | | | |
|-------|--------------------------|--|---------|--------------------|--------------------|----------------------|
| Lewis | Laborers | High Scaler | \$50.42 | 7A | 3I | View |
| Lewis | Laborers | Jackhammer | \$49.81 | 7A | 3I | View |
| Lewis | Laborers | Laserbeam Operator | \$49.81 | 7A | 3I | View |
| Lewis | Laborers | Maintenance Person | \$48.90 | 7A | 3I | View |
| Lewis | Laborers | Manhole Builder-mudman | \$49.81 | 7A | 3I | View |
| Lewis | Laborers | Material Yard Person | \$48.90 | 7A | 3I | View |
| Lewis | Laborers | Motorman-dinky Locomotive | \$49.81 | 7A | 3I | View |
| Lewis | Laborers | Nozzleman (concrete Pump, Green Cutter When Using Combination Of High Pressure Air & Water On Concrete & Rock, Sandblast, Guniting, Shotcrete, Water Bla | \$49.81 | 7A | 3I | View |
| Lewis | Laborers | Pavement Breaker | \$49.81 | 7A | 3I | View |
| Lewis | Laborers | Pilot Car | \$41.45 | 7A | 3I | View |
| Lewis | Laborers | Pipe Layer Lead | \$50.42 | 7A | 3I | View |
| Lewis | Laborers | Pipe Layer/tailor | \$49.81 | 7A | 3I | View |
| Lewis | Laborers | Pipe Pot Tender | \$49.81 | 7A | 3I | View |
| Lewis | Laborers | Pipe Reliner | \$49.81 | 7A | 3I | View |
| Lewis | Laborers | Pipe Wrapper | \$49.81 | 7A | 3I | View |
| Lewis | Laborers | Pot Tender | \$48.90 | 7A | 3I | View |
| Lewis | Laborers | Powderman | \$50.42 | 7A | 3I | View |
| Lewis | Laborers | Powderman's Helper | \$48.90 | 7A | 3I | View |
| Lewis | Laborers | Power Jacks | \$49.81 | 7A | 3I | View |
| Lewis | Laborers | Railroad Spike Puller - Power | \$49.81 | 7A | 3I | View |
| Lewis | Laborers | Raker - Asphalt | \$50.42 | 7A | 3I | View |
| Lewis | Laborers | Re-timberman | \$50.42 | 7A | 3I | View |
| Lewis | Laborers | Remote Equipment Operator | \$49.81 | 7A | 3I | View |
| Lewis | Laborers | Rigger/signal Person | \$49.81 | 7A | 3I | View |
| Lewis | Laborers | Rip Rap Person | \$48.90 | 7A | 3I | View |
| Lewis | Laborers | Rivet Buster | \$49.81 | 7A | 3I | View |
| Lewis | Laborers | Rodder | \$49.81 | 7A | 3I | View |
| Lewis | Laborers | Scaffold Erector | \$48.90 | 7A | 3I | View |
| Lewis | Laborers | Scale Person | \$48.90 | 7A | 3I | View |
| Lewis | Laborers | Sloper (over 20") | \$49.81 | 7A | 3I | View |
| Lewis | Laborers | Sloper Sprayer | \$48.90 | 7A | 3I | View |
| Lewis | Laborers | Spreader (concrete) | \$49.81 | 7A | 3I | View |
| Lewis | Laborers | Stake Hopper | \$48.90 | 7A | 3I | View |
| Lewis | Laborers | Stock Piler | \$48.90 | 7A | 3I | View |
| Lewis | Laborers | Tamper & Similar Electric, Air & Gas Operated Tools | \$49.81 | 7A | 3I | View |
| Lewis | Laborers | Tamper (multiple & Self- propelled) | \$49.81 | 7A | 3I | View |
| Lewis | Laborers | Timber Person - Sewer (lagger, Shorer & Cribber) | \$49.81 | 7A | 3I | View |

| | | | | | | | |
|-------|--|---|----------|--------------------|--------------------|--------------------|----------------------|
| Lewis | Laborers | Toolroom Person (at Jobsite) | \$48.90 | 7A | 3I | | View |
| Lewis | Laborers | Topper | \$48.90 | 7A | 3I | | View |
| Lewis | Laborers | Track Laborer | \$48.90 | 7A | 3I | | View |
| Lewis | Laborers | Track Liner (power) | \$49.81 | 7A | 3I | | View |
| Lewis | Laborers | Traffic Control Laborer | \$44.33 | 7A | 3I | 8R | View |
| Lewis | Laborers | Traffic Control Supervisor | \$44.33 | 7A | 3I | 8R | View |
| Lewis | Laborers | Truck Spotter | \$48.90 | 7A | 3I | | View |
| Lewis | Laborers | Tugger Operator | \$49.81 | 7A | 3I | | View |
| Lewis | Laborers | Tunnel Work-Compressed Air Worker 0-30 psi | \$107.60 | 7A | 3I | 8Q | View |
| Lewis | Laborers | Tunnel Work-Compressed Air Worker 30.01-44.00 psi | \$112.63 | 7A | 3I | 8Q | View |
| Lewis | Laborers | Tunnel Work-Compressed Air Worker 44.01-54.00 psi | \$116.31 | 7A | 3I | 8Q | View |
| Lewis | Laborers | Tunnel Work-Compressed Air Worker 54.01-60.00 psi | \$122.01 | 7A | 3I | 8Q | View |
| Lewis | Laborers | Tunnel Work-Compressed Air Worker 60.01-64.00 psi | \$124.13 | 7A | 3I | 8Q | View |
| Lewis | Laborers | Tunnel Work-Compressed Air Worker 64.01-68.00 psi | \$129.23 | 7A | 3I | 8Q | View |
| Lewis | Laborers | Tunnel Work-Compressed Air Worker 68.01-70.00 psi | \$131.13 | 7A | 3I | 8Q | View |
| Lewis | Laborers | Tunnel Work-Compressed Air Worker 70.01-72.00 psi | \$133.13 | 7A | 3I | 8Q | View |
| Lewis | Laborers | Tunnel Work-Compressed Air Worker 72.01-74.00 psi | \$135.13 | 7A | 3I | 8Q | View |
| Lewis | Laborers | Tunnel Work-Guage and Lock Tender | \$50.52 | 7A | 3I | 8Q | View |
| Lewis | Laborers | Tunnel Work-Miner | \$50.52 | 7A | 3I | 8Q | View |
| Lewis | Laborers | Vibrator | \$49.81 | 7A | 3I | | View |
| Lewis | Laborers | Vinyl Seamer | \$48.90 | 7A | 3I | | View |
| Lewis | Laborers | Watchman | \$37.67 | 7A | 3I | | View |
| Lewis | Laborers | Welder | \$49.81 | 7A | 3I | | View |
| Lewis | Laborers | Well Point Laborer | \$49.81 | 7A | 3I | | View |
| Lewis | Laborers | Window Washer/cleaner | \$37.67 | 7A | 3I | | View |
| Lewis | Laborers - Underground Sewer & Water | General Laborer & Topman | \$48.90 | 7A | 3I | | View |
| Lewis | Laborers - Underground Sewer & Water | Pipe Layer | \$49.81 | 7A | 3I | | View |
| Lewis | Landscape Construction | Landscape Laborer | \$37.67 | 7A | 3I | | View |
| Lewis | Landscape Construction | Landscape Operator | \$62.71 | 7A | 3K | 8X | View |
| Lewis | Landscape Maintenance | Groundskeeper | \$12.00 | | 1 | | View |

| | | | | | | |
|-------|--|---|----------|-----------|-----------|----------------------|
| Lewis | Lathers | Journey Level | \$58.48 | <u>5D</u> | <u>1H</u> | View |
| Lewis | Marble Setters | Journey Level | \$57.32 | <u>5A</u> | <u>1M</u> | View |
| Lewis | Metal Fabrication (In Shop) | Fitter | \$15.16 | | <u>1</u> | View |
| Lewis | Metal Fabrication (In Shop) | Laborer | \$12.00 | | <u>1</u> | View |
| Lewis | Metal Fabrication (In Shop) | Machine Operator | \$12.00 | | <u>1</u> | View |
| Lewis | Metal Fabrication (In Shop) | Painter | \$12.00 | | <u>1</u> | View |
| Lewis | Metal Fabrication (In Shop) | Welder | \$15.16 | | <u>1</u> | View |
| Lewis | Millwright | Journey Level | \$61.54 | <u>5D</u> | <u>4C</u> | View |
| Lewis | Modular Buildings | Cabinet Assembly | \$12.00 | | <u>1</u> | View |
| Lewis | Modular Buildings | Electrician | \$12.00 | | <u>1</u> | View |
| Lewis | Modular Buildings | Equipment Maintenance | \$12.00 | | <u>1</u> | View |
| Lewis | Modular Buildings | Plumber | \$12.00 | | <u>1</u> | View |
| Lewis | Modular Buildings | Production Worker | \$12.00 | | <u>1</u> | View |
| Lewis | Modular Buildings | Tool Maintenance | \$12.00 | | <u>1</u> | View |
| Lewis | Modular Buildings | Utility Person | \$12.00 | | <u>1</u> | View |
| Lewis | Modular Buildings | Welder | \$12.00 | | <u>1</u> | View |
| Lewis | Painters | Journey Level | \$42.50 | <u>6Z</u> | <u>2B</u> | View |
| Lewis | Pile Driver | Crew Tender/Technician | \$64.71 | <u>5D</u> | <u>4C</u> | View |
| Lewis | Pile Driver | Hyperbaric Worker - Compressed Air Worker 0- 30.00 PSI | \$74.87 | <u>5D</u> | <u>4C</u> | View |
| Lewis | Pile Driver | Hyperbaric Worker - Compressed Air Worker 30.01 - 44.00 PSI | \$79.87 | <u>5D</u> | <u>4C</u> | View |
| Lewis | Pile Driver | Hyperbaric Worker - Compressed Air Worker 44.01 - 54.00 PSI | \$83.87 | <u>5D</u> | <u>4C</u> | View |
| Lewis | Pile Driver | Hyperbaric Worker - Compressed Air Worker 54.01 - 60.00 PSI | \$88.87 | <u>5D</u> | <u>4C</u> | View |
| Lewis | Pile Driver | Hyperbaric Worker - Compressed Air Worker 60.01 - 64.00 PSI | \$91.37 | <u>5D</u> | <u>4C</u> | View |
| Lewis | Pile Driver | Hyperbaric Worker - Compressed Air Worker 64.01 - 68.00 PSI | \$96.37 | <u>5D</u> | <u>4C</u> | View |
| Lewis | Pile Driver | Hyperbaric Worker - Compressed Air Worker 68.01 - 70.00 PSI | \$98.37 | <u>5D</u> | <u>4C</u> | View |
| Lewis | Pile Driver | Hyperbaric Worker - Compressed Air Worker 70.01 - 72.00 PSI | \$100.37 | <u>5D</u> | <u>4C</u> | View |
| Lewis | Pile Driver | Hyperbaric Worker - Compressed Air Worker 72.01 - 74.00 PSI | \$102.37 | <u>5D</u> | <u>4C</u> | View |
| Lewis | Pile Driver | Journey Level | \$60.29 | <u>5D</u> | <u>4C</u> | View |
| Lewis | Pile Driver | Manifold Operator (LST) | \$69.71 | <u>5D</u> | <u>4C</u> | View |
| Lewis | Plasterers | Journey Level | \$56.54 | <u>7Q</u> | <u>1R</u> | View |
| Lewis | Playground & Park Equipment Installers | Journey Level | \$12.00 | | <u>1</u> | View |
| Lewis | Plumbers & Pipefitters | Journey Level | \$71.42 | <u>5A</u> | <u>1G</u> | View |

| | | | | | | | |
|-------|---|---|---------|--------------------|--------------------|--------------------|----------------------|
| Lewis | Power Equipment Operators | Asphalt Plant Operator | \$63.76 | 7A | 3K | 8X | View |
| Lewis | Power Equipment Operators | Assistant Engineers | \$59.98 | 7A | 3K | 8X | View |
| Lewis | Power Equipment Operators | Barrier Machine (zipper) | \$63.20 | 7A | 3K | 8X | View |
| Lewis | Power Equipment Operators | Batch Plant Operator: Concrete | \$63.20 | 7A | 3K | 8X | View |
| Lewis | Power Equipment Operators | Bobcat | \$59.98 | 7A | 3K | 8X | View |
| Lewis | Power Equipment Operators | Brokk - Remote Demolition Equipment | \$59.98 | 7A | 3K | 8X | View |
| Lewis | Power Equipment Operators | Brooms | \$59.98 | 7A | 3K | 8X | View |
| Lewis | Power Equipment Operators | Bump Cutter | \$63.20 | 7A | 3K | 8X | View |
| Lewis | Power Equipment Operators | Cableways | \$63.76 | 7A | 3K | 8X | View |
| Lewis | Power Equipment Operators | Chipper | \$63.20 | 7A | 3K | 8X | View |
| Lewis | Power Equipment Operators | Compressor | \$59.98 | 7A | 3K | 8X | View |
| Lewis | Power Equipment Operators | Concrete Pump: Truck Mount With Boom Attachment Over 42m | \$63.76 | 7A | 3K | 8X | View |
| Lewis | Power Equipment Operators | Concrete Finish Machine - laser Screed | \$59.98 | 7A | 3K | 8X | View |
| Lewis | Power Equipment Operators | Concrete Pump - Mounted Or Trailer High Pressure Line Pump, Pump High Pressure | \$62.71 | 7A | 3K | 8X | View |
| Lewis | Power Equipment Operators | Concrete Pump: Truck Mount With Boom Attachment Up To 42m | \$63.20 | 7A | 3K | 8X | View |
| Lewis | Power Equipment Operators | Conveyors | \$62.71 | 7A | 3K | 8X | View |
| Lewis | Power Equipment Operators | Cranes, 100 Tons - 199 Tons, Or 150 Ft Of Boom (including Jib With Attachments) | \$64.41 | 7A | 3K | 8X | View |
| Lewis | Power Equipment Operators | Cranes: 20 Tons Through 44 Tons With Attachments | \$63.20 | 7A | 3K | 8X | View |
| Lewis | Power Equipment Operators | Cranes: 200 tons to 299 tons, or 250' of boom (including jib with attachments) | \$65.06 | 7A | 3K | 8X | View |
| Lewis | Power Equipment Operators | Cranes: 300 tons and over, or 300' of boom (including jib with attachments) | \$65.70 | 7A | 3K | 8X | View |
| Lewis | Power Equipment Operators | Cranes: 45 Tons Through 99 Tons, Under 150' Of Boom (including Jib With Attachments) | \$63.76 | 7A | 3K | 8X | View |
| Lewis | Power Equipment Operators | Cranes: A-frame - 10 Tons And Under | \$59.98 | 7A | 3K | 8X | View |
| Lewis | Power Equipment Operators | Cranes: Friction 200 tons and over. Tower Cranes: over 250' in height from base to boom. | \$65.70 | 7A | 3K | 8X | View |
| Lewis | Power Equipment Operators | Cranes: Friction cranes through 199 tons | \$65.06 | 7A | 3K | 8X | View |

| | | | | | | | |
|-------|---|--|---------|--------------------|--------------------|--------------------|----------------------|
| Lewis | Power Equipment Operators | Cranes: Through 19 Tons With Attachments A-frame Over 10 Tons | \$62.71 | 7A | 3K | 8X | View |
| Lewis | Power Equipment Operators | Crusher | \$63.20 | 7A | 3K | 8X | View |
| Lewis | Power Equipment Operators | Deck Engineer/deck Winches (power) | \$63.20 | 7A | 3K | 8X | View |
| Lewis | Power Equipment Operators | Derricks, On Building Work | \$63.76 | 7A | 3K | 8X | View |
| Lewis | Power Equipment Operators | Dozers D-9 & Under | \$62.71 | 7A | 3K | 8X | View |
| Lewis | Power Equipment Operators | Drill Oilers: Auger Type, Truck Or Crane Mount | \$62.71 | 7A | 3K | 8X | View |
| Lewis | Power Equipment Operators | Drilling Machine | \$64.41 | 7A | 3K | 8X | View |
| Lewis | Power Equipment Operators | Elevator And Man-lift: Permanent And Shaft Type | \$59.98 | 7A | 3K | 8X | View |
| Lewis | Power Equipment Operators | Finishing Machine, Bidwell And Gamaco & Similar Equipment | \$63.20 | 7A | 3K | 8X | View |
| Lewis | Power Equipment Operators | Forklift: 3000 Lbs And Over With Attachments | \$62.71 | 7A | 3K | 8X | View |
| Lewis | Power Equipment Operators | Forklifts: Under 3000 Lbs. With Attachments | \$59.98 | 7A | 3K | 8X | View |
| Lewis | Power Equipment Operators | Grade Engineer: Using Blueprints, Cut Sheets,etc. | \$63.20 | 7A | 3K | 8X | View |
| Lewis | Power Equipment Operators | Gradechecker/stakeman | \$59.98 | 7A | 3K | 8X | View |
| Lewis | Power Equipment Operators | Guardrail punch/Auger | \$63.20 | 7A | 3K | 8X | View |
| Lewis | Power Equipment Operators | Hard Tail End Dump Articulating Off- Road Equipment 45 Yards. & Over | \$63.76 | 7A | 3K | 8X | View |
| Lewis | Power Equipment Operators | Hard Tail End Dump Articulating Off-road Equipment Under 45 Yards | \$63.20 | 7A | 3K | 8X | View |
| Lewis | Power Equipment Operators | Horizontal/directional Drill Locator | \$62.71 | 7A | 3K | 8X | View |
| Lewis | Power Equipment Operators | Horizontal/directional Drill Operator | \$63.20 | 7A | 3K | 8X | View |
| Lewis | Power Equipment Operators | Hydralifts/Boom Trucks Over 10 Tons | \$62.71 | 7A | 3K | 8X | View |
| Lewis | Power Equipment Operators | Hydralifts/boom Trucks, 10 Tons And Under | \$59.98 | 7A | 3K | 8X | View |
| Lewis | Power Equipment Operators | Loader, Overhead 8 Yards. & Over | \$64.41 | 7A | 3K | 8X | View |
| Lewis | Power Equipment Operators | Loader, Overhead, 6 Yards. But Not Including 8 Yards | \$63.76 | 7A | 3K | 8X | View |
| Lewis | Power Equipment Operators | Loaders, Overhead Under 6 Yards | \$63.20 | 7A | 3K | 8X | View |
| Lewis | Power Equipment Operators | Loaders, Plant Feed | \$63.20 | 7A | 3K | 8X | View |
| Lewis | Power Equipment Operators | Loaders: Elevating Type Belt | \$62.71 | 7A | 3K | 8X | View |

| | | | | | | | |
|-------|---|--|---------|--------------------|--------------------|--------------------|----------------------|
| Lewis | Power Equipment Operators | Locomotives, All | \$63.20 | 7A | 3K | 8X | View |
| Lewis | Power Equipment Operators | Material Transfer Device | \$63.20 | 7A | 3K | 8X | View |
| Lewis | Power Equipment Operators | Mechanics, All (Leadmen - \$0.50 Per Hour Over Mechanic) | \$64.41 | 7A | 3K | 8X | View |
| Lewis | Power Equipment Operators | Motor patrol graders | \$63.76 | 7A | 3K | 8X | View |
| Lewis | Power Equipment Operators | Mucking Machine, Mole, Tunnel Drill, Boring, Road Header And/or Shield | \$63.76 | 7A | 3K | 8X | View |
| Lewis | Power Equipment Operators | Oil Distributors, Blower Distribution & Mulch Seeding Operator | \$59.98 | 7A | 3K | 8X | View |
| Lewis | Power Equipment Operators | Outside Hoists (elevators And Manlifts), Air Tuggers, strato | \$62.71 | 7A | 3K | 8X | View |
| Lewis | Power Equipment Operators | Overhead, Bridge Type Crane: 20 Tons Through 44 Tons | \$63.20 | 7A | 3K | 8X | View |
| Lewis | Power Equipment Operators | Overhead, Bridge Type: 100 Tons And Over | \$64.41 | 7A | 3K | 8X | View |
| Lewis | Power Equipment Operators | Overhead, Bridge Type: 45 Tons Through 99 Tons | \$63.76 | 7A | 3K | 8X | View |
| Lewis | Power Equipment Operators | Pavement Breaker | \$59.98 | 7A | 3K | 8X | View |
| Lewis | Power Equipment Operators | Pile Driver (other Than Crane Mount) | \$63.20 | 7A | 3K | 8X | View |
| Lewis | Power Equipment Operators | Plant Oiler - Asphalt, Crusher | \$62.71 | 7A | 3K | 8X | View |
| Lewis | Power Equipment Operators | Posthole Digger, Mechanical | \$59.98 | 7A | 3K | 8X | View |
| Lewis | Power Equipment Operators | Power Plant | \$59.98 | 7A | 3K | 8X | View |
| Lewis | Power Equipment Operators | Pumps - Water | \$59.98 | 7A | 3K | 8X | View |
| Lewis | Power Equipment Operators | Quad 9, HD 41, D10 And Over | \$63.76 | 7A | 3K | 8X | View |
| Lewis | Power Equipment Operators | Quick Tower - No Cab, Under 100 Feet In Height Based To Boom | \$59.98 | 7A | 3K | 8X | View |
| Lewis | Power Equipment Operators | Remote Control Operator On Rubber Tired Earth Moving Equipment | \$63.76 | 7A | 3K | 8X | View |
| Lewis | Power Equipment Operators | Rigger And Bellman | \$59.98 | 7A | 3K | 8X | View |
| Lewis | Power Equipment Operators | Rigger/Signal Person, Bellman (Certified) | \$62.71 | 7A | 3K | 8X | View |
| Lewis | Power Equipment Operators | Rollagon | \$63.76 | 7A | 3K | 8X | View |
| Lewis | Power Equipment Operators | Roller, Other Than Plant Mix | \$59.98 | 7A | 3K | 8X | View |
| Lewis | Power Equipment Operators | Roller, Plant Mix Or Multi-lift Materials | \$62.71 | 7A | 3K | 8X | View |
| Lewis | Power Equipment Operators | Roto-mill, Roto-grinder | \$63.20 | 7A | 3K | 8X | View |
| Lewis | Power Equipment Operators | Saws - Concrete | \$62.71 | 7A | 3K | 8X | View |
| Lewis | Power Equipment Operators | Scraper, Self Propelled Under 45 Yards | \$63.20 | 7A | 3K | 8X | View |
| Lewis | Power Equipment Operators | Scrapers - Concrete & | \$62.71 | 7A | 3K | 8X | View |

| | | | | | | | |
|-------|--|--|---------|--------------------|--------------------|--------------------|----------------------|
| | | Carry All | | | | | |
| Lewis | Power Equipment Operators | Scrapers, Self-propelled: 45 Yards And Over | \$63.76 | 7A | 3K | 8X | View |
| Lewis | Power Equipment Operators | Service Engineers - Equipment | \$62.71 | 7A | 3K | 8X | View |
| Lewis | Power Equipment Operators | Shotcrete/gunite Equipment | \$59.98 | 7A | 3K | 8X | View |
| Lewis | Power Equipment Operators | Shovel , Excavator, Backhoe, Tractors Under 15 Metric Tons. | \$62.71 | 7A | 3K | 8X | View |
| Lewis | Power Equipment Operators | Shovel, Excavator, Backhoe: Over 30 Metric Tons To 50 Metric Tons | \$63.76 | 7A | 3K | 8X | View |
| Lewis | Power Equipment Operators | Shovel, Excavator, Backhoes, Tractors: 15 To 30 Metric Tons | \$63.20 | 7A | 3K | 8X | View |
| Lewis | Power Equipment Operators | Shovel, Excavator, Backhoes: Over 50 Metric Tons To 90 Metric Tons | \$64.41 | 7A | 3K | 8X | View |
| Lewis | Power Equipment Operators | Shovel, Excavator, Backhoes: Over 90 Metric Tons | \$65.06 | 7A | 3K | 8X | View |
| Lewis | Power Equipment Operators | Slipform Pavers | \$63.76 | 7A | 3K | 8X | View |
| Lewis | Power Equipment Operators | Spreader, Topsider & Screedman | \$63.76 | 7A | 3K | 8X | View |
| Lewis | Power Equipment Operators | Subgrader Trimmer | \$63.20 | 7A | 3K | 8X | View |
| Lewis | Power Equipment Operators | Tower Bucket Elevators | \$62.71 | 7A | 3K | 8X | View |
| Lewis | Power Equipment Operators | Tower crane over 175' through 250' in height, base to boom | \$65.06 | 7A | 3K | 8X | View |
| Lewis | Power Equipment Operators | Tower Crane Up: To 175' In Height, Base To Boom | \$64.41 | 7A | 3K | 8X | View |
| Lewis | Power Equipment Operators | Transporters, All Track Or Truck Type | \$63.76 | 7A | 3K | 8X | View |
| Lewis | Power Equipment Operators | Trenching Machines | \$62.71 | 7A | 3K | 8X | View |
| Lewis | Power Equipment Operators | Truck Crane Oiler/driver - 100 Tons And Over | \$63.20 | 7A | 3K | 8X | View |
| Lewis | Power Equipment Operators | Truck Crane Oiler/driver Under 100 Tons | \$62.71 | 7A | 3K | 8X | View |
| Lewis | Power Equipment Operators | Truck Mount Portable Conveyor | \$63.20 | 7A | 3K | 8X | View |
| Lewis | Power Equipment Operators | Welder | \$63.76 | 7A | 3K | 8X | View |
| Lewis | Power Equipment Operators | Wheel Tractors, Farmall Type | \$59.98 | 7A | 3K | 8X | View |
| Lewis | Power Equipment Operators | Yo Yo Pay Dozer | \$63.20 | 7A | 3K | 8X | View |
| Lewis | Power Equipment Operators- Underground Sewer & Water | Asphalt Plant Operator | \$63.76 | 7A | 3K | 8X | View |
| Lewis | Power Equipment Operators- Underground Sewer & Water | Assistant Engineers | \$59.98 | 7A | 3K | 8X | View |
| Lewis | Power Equipment Operators- Underground | Barrier Machine (zipper) | \$63.20 | 7A | 3K | 8X | View |

| | | | | | | | |
|-------|--|---|---------|--------------------|--------------------|--------------------|----------------------|
| | Sewer & Water | | | | | | |
| Lewis | Power Equipment Operators- Underground Sewer & Water | Batch Plant Operator: Concrete | \$63.20 | 7A | 3K | 8X | View |
| Lewis | Power Equipment Operators- Underground Sewer & Water | Bobcat | \$59.98 | 7A | 3K | 8X | View |
| Lewis | Power Equipment Operators- Underground Sewer & Water | Brokk - Remote Demolition Equipment | \$59.98 | 7A | 3K | 8X | View |
| Lewis | Power Equipment Operators- Underground Sewer & Water | Brooms | \$59.98 | 7A | 3K | 8X | View |
| Lewis | Power Equipment Operators- Underground Sewer & Water | Bump Cutter | \$63.20 | 7A | 3K | 8X | View |
| Lewis | Power Equipment Operators- Underground Sewer & Water | Cableways | \$63.76 | 7A | 3K | 8X | View |
| Lewis | Power Equipment Operators- Underground Sewer & Water | Chipper | \$63.20 | 7A | 3K | 8X | View |
| Lewis | Power Equipment Operators- Underground Sewer & Water | Compressor | \$59.98 | 7A | 3K | 8X | View |
| Lewis | Power Equipment Operators- Underground Sewer & Water | Concrete Pump: Truck Mount With Boom Attachment Over 42m | \$63.76 | 7A | 3K | 8X | View |
| Lewis | Power Equipment Operators- Underground Sewer & Water | Concrete Finish Machine - laser Screed | \$59.98 | 7A | 3K | 8X | View |
| Lewis | Power Equipment Operators- Underground Sewer & Water | Concrete Pump - Mounted Or Trailer High Pressure Line Pump, Pump High Pressure | \$62.71 | 7A | 3K | 8X | View |
| Lewis | Power Equipment Operators- Underground Sewer & Water | Concrete Pump: Truck Mount With Boom Attachment Up To 42m | \$63.20 | 7A | 3K | 8X | View |
| Lewis | Power Equipment Operators- Underground Sewer & Water | Conveyors | \$62.71 | 7A | 3K | 8X | View |
| Lewis | Power Equipment Operators- Underground Sewer & Water | Cranes, 100 Tons - 199 Tons, Or 150 Ft Of Boom (including Jib With Attachments) | \$64.41 | 7A | 3K | 8X | View |
| Lewis | Power Equipment Operators- Underground Sewer & Water | Cranes, 200 tons to 299 tons, or 250' of boom (including jib with attachments) | \$65.06 | 7A | 3K | 8X | View |
| Lewis | Power Equipment Operators- Underground Sewer & Water | Cranes, Over 300 Tons, Or 300' Of Boom Including Jib With Attachments | \$65.70 | 7A | 3K | 8X | View |
| Lewis | Power Equipment Operators- Underground Sewer & Water | Cranes: 20 Tons Through 44 Tons With Attachments | \$63.20 | 7A | 3K | 8X | View |

| | | | | | | | |
|-------|--|--|---------|--------------------|--------------------|--------------------|----------------------|
| Lewis | Power Equipment Operators- Underground Sewer & Water | cranes: 300 tons and over, or 300' of boom (including jib with attachments) | \$65.70 | 7A | 3K | 8X | View |
| Lewis | Power Equipment Operators- Underground Sewer & Water | Cranes: 45 Tons Through 99 Tons, Under 150' Of Boom (including Jib With Attachments) | \$63.76 | 7A | 3K | 8X | View |
| Lewis | Power Equipment Operators- Underground Sewer & Water | Cranes: A-frame - 10 Tons And Under | \$59.98 | 7A | 3K | 8X | View |
| Lewis | Power Equipment Operators- Underground Sewer & Water | Cranes: Friction 200 tons and over. Tower Cranes: over 250' in height from base to boom. | \$65.70 | 7A | 3K | 8X | View |
| Lewis | Power Equipment Operators- Underground Sewer & Water | Cranes: Friction cranes through 199 tons | \$65.06 | 7A | 3K | 8X | View |
| Lewis | Power Equipment Operators- Underground Sewer & Water | Cranes: Through 19 Tons With Attachments A-frame Over 10 Tons | \$62.71 | 7A | 3K | 8X | View |
| Lewis | Power Equipment Operators- Underground Sewer & Water | Crusher | \$63.20 | 7A | 3K | 8X | View |
| Lewis | Power Equipment Operators- Underground Sewer & Water | Deck Engineer/deck Winches (power) | \$63.20 | 7A | 3K | 8X | View |
| Lewis | Power Equipment Operators- Underground Sewer & Water | Derricks, On Building Work | \$63.76 | 7A | 3K | 8X | View |
| Lewis | Power Equipment Operators- Underground Sewer & Water | Dozers D-9 & Under | \$62.71 | 7A | 3K | 8X | View |
| Lewis | Power Equipment Operators- Underground Sewer & Water | Drill Oilers: Auger Type, Truck Or Crane Mount | \$62.71 | 7A | 3K | 8X | View |
| Lewis | Power Equipment Operators- Underground Sewer & Water | Drilling Machine | \$64.41 | 7A | 3K | 8X | View |
| Lewis | Power Equipment Operators- Underground Sewer & Water | Elevator And Man-lift: Permanent And Shaft Type | \$59.98 | 7A | 3K | 8X | View |
| Lewis | Power Equipment Operators- Underground Sewer & Water | Finishing Machine, Bidwell And Gamaco & Similar Equipment | \$63.20 | 7A | 3K | 8X | View |
| Lewis | Power Equipment Operators- Underground Sewer & Water | Forklift: 3000 Lbs And Over With Attachments | \$62.71 | 7A | 3K | 8X | View |
| Lewis | Power Equipment Operators- Underground Sewer & Water | Forklifts: Under 3000 Lbs. With Attachments | \$59.98 | 7A | 3K | 8X | View |
| Lewis | Power Equipment Operators- Underground Sewer & Water | Grade Engineer: Using Blueprints, Cut Sheets,etc. | \$63.20 | 7A | 3K | 8X | View |
| Lewis | Power Equipment | Gradechecker/stakeman | \$59.98 | 7A | 3K | 8X | View |

| | | | | | | | |
|-------|--|--|---------|--------------------|--------------------|--------------------|----------------------|
| | Operators- Underground Sewer & Water | | | | | | |
| Lewis | Power Equipment Operators- Underground Sewer & Water | Guardrail punch/Auger | \$63.20 | 7A | 3K | 8X | View |
| Lewis | Power Equipment Operators- Underground Sewer & Water | Hard Tail End Dump Articulating Off- Road Equipment 45 Yards. & Over | \$63.76 | 7A | 3K | 8X | View |
| Lewis | Power Equipment Operators- Underground Sewer & Water | Hard Tail End Dump Articulating Off-road Equipment Under 45 Yards | \$63.20 | 7A | 3K | 8X | View |
| Lewis | Power Equipment Operators- Underground Sewer & Water | Horizontal/directional Drill Locator | \$62.71 | 7A | 3K | 8X | View |
| Lewis | Power Equipment Operators- Underground Sewer & Water | Horizontal/directional Drill Operator | \$63.20 | 7A | 3K | 8X | View |
| Lewis | Power Equipment Operators- Underground Sewer & Water | Hydralifts/Boom Trucks Over 10 Tons | \$62.71 | 7A | 3K | 8X | View |
| Lewis | Power Equipment Operators- Underground Sewer & Water | Hydralifts/boom Trucks, 10 Tons And Under | \$59.98 | 7A | 3K | 8X | View |
| Lewis | Power Equipment Operators- Underground Sewer & Water | Loader, Overhead 8 Yards. & Over | \$64.41 | 7A | 3K | 8X | View |
| Lewis | Power Equipment Operators- Underground Sewer & Water | Loader, Overhead, 6 Yards. But Not Including 8 Yards | \$63.76 | 7A | 3K | 8X | View |
| Lewis | Power Equipment Operators- Underground Sewer & Water | Loaders, Overhead Under 6 Yards | \$63.20 | 7A | 3K | 8X | View |
| Lewis | Power Equipment Operators- Underground Sewer & Water | Loaders, Plant Feed | \$63.20 | 7A | 3K | 8X | View |
| Lewis | Power Equipment Operators- Underground Sewer & Water | Loaders: Elevating Type Belt | \$62.71 | 7A | 3K | 8X | View |
| Lewis | Power Equipment Operators- Underground Sewer & Water | Locomotives, All | \$63.20 | 7A | 3K | 8X | View |
| Lewis | Power Equipment Operators- Underground Sewer & Water | Material Transfer Device | \$63.20 | 7A | 3K | 8X | View |
| Lewis | Power Equipment Operators- Underground Sewer & Water | Mechanics, All (Leadmen - \$0.50 Per Hour Over Mechanic) | \$64.41 | 7A | 3K | 8X | View |
| Lewis | Power Equipment Operators- Underground Sewer & Water | Motor patrol graders | \$63.76 | 7A | 3K | 8X | View |
| Lewis | Power Equipment Operators- Underground Sewer & Water | Mucking Machine, Mole, Tunnel Drill, Boring, Road Header And/or Shield | \$63.76 | 7A | 3K | 8X | View |

| | | | | | | | |
|-------|--|--|---------|--------------------|--------------------|--------------------|----------------------|
| Lewis | Power Equipment Operators- Underground Sewer & Water | Oil Distributors, Blower Distribution & Mulch Seeding Operator | \$59.98 | 7A | 3K | 8X | View |
| Lewis | Power Equipment Operators- Underground Sewer & Water | Outside Hoists (elevators And Manlifts), Air Tuggers, strato | \$62.71 | 7A | 3K | 8X | View |
| Lewis | Power Equipment Operators- Underground Sewer & Water | Overhead, Bridge Type Crane: 20 Tons Through 44 Tons | \$63.20 | 7A | 3K | 8X | View |
| Lewis | Power Equipment Operators- Underground Sewer & Water | Overhead, Bridge Type: 100 Tons And Over | \$64.41 | 7A | 3K | 8X | View |
| Lewis | Power Equipment Operators- Underground Sewer & Water | Overhead, Bridge Type: 45 Tons Through 99 Tons | \$63.76 | 7A | 3K | 8X | View |
| Lewis | Power Equipment Operators- Underground Sewer & Water | Pavement Breaker | \$59.98 | 7A | 3K | 8X | View |
| Lewis | Power Equipment Operators- Underground Sewer & Water | Pile Driver (other Than Crane Mount) | \$63.20 | 7A | 3K | 8X | View |
| Lewis | Power Equipment Operators- Underground Sewer & Water | Plant Oiler - Asphalt, Crusher | \$62.71 | 7A | 3K | 8X | View |
| Lewis | Power Equipment Operators- Underground Sewer & Water | Posthole Digger, Mechanical | \$59.98 | 7A | 3K | 8X | View |
| Lewis | Power Equipment Operators- Underground Sewer & Water | Power Plant | \$59.98 | 7A | 3K | 8X | View |
| Lewis | Power Equipment Operators- Underground Sewer & Water | Pumps - Water | \$59.98 | 7A | 3K | 8X | View |
| Lewis | Power Equipment Operators- Underground Sewer & Water | Quad 9, HD 41, D10 And Over | \$63.76 | 7A | 3K | 8X | View |
| Lewis | Power Equipment Operators- Underground Sewer & Water | Quick Tower - No Cab, Under 100 Feet In Height Based To Boom | \$59.98 | 7A | 3K | 8X | View |
| Lewis | Power Equipment Operators- Underground Sewer & Water | Remote Control Operator On Rubber Tired Earth Moving Equipment | \$63.76 | 7A | 3K | 8X | View |
| Lewis | Power Equipment Operators- Underground Sewer & Water | Rigger And Bellman | \$59.98 | 7A | 3K | 8X | View |
| Lewis | Power Equipment Operators- Underground Sewer & Water | Rigger/Signal Person, Bellman (Certified) | \$62.71 | 7A | 3K | 8X | View |
| Lewis | Power Equipment Operators- Underground Sewer & Water | Rollagon | \$63.76 | 7A | 3K | 8X | View |
| Lewis | Power Equipment Operators- Underground Sewer & Water | Roller, Other Than Plant Mix | \$59.98 | 7A | 3K | 8X | View |
| Lewis | Power Equipment | Roller, Plant Mix Or Multi- | \$62.71 | 7A | 3K | 8X | View |

| | | | | | | | |
|-------|--|--|---------|--------------------|--------------------|--------------------|----------------------|
| | Operators- Underground Sewer & Water | lift Materials | | | | | |
| Lewis | Power Equipment Operators- Underground Sewer & Water | Roto-mill, Roto-grinder | \$63.20 | 7A | 3K | 8X | View |
| Lewis | Power Equipment Operators- Underground Sewer & Water | Saws - Concrete | \$62.71 | 7A | 3K | 8X | View |
| Lewis | Power Equipment Operators- Underground Sewer & Water | Scraper, Self Propelled Under 45 Yards | \$63.20 | 7A | 3K | 8X | View |
| Lewis | Power Equipment Operators- Underground Sewer & Water | Scrapers - Concrete & Carry All | \$62.71 | 7A | 3K | 8X | View |
| Lewis | Power Equipment Operators- Underground Sewer & Water | Scrapers, Self-propelled: 45 Yards And Over | \$63.76 | 7A | 3K | 8X | View |
| Lewis | Power Equipment Operators- Underground Sewer & Water | Service Engineers - Equipment | \$62.71 | 7A | 3K | 8X | View |
| Lewis | Power Equipment Operators- Underground Sewer & Water | Shotcrete/gunite Equipment | \$59.98 | 7A | 3K | 8X | View |
| Lewis | Power Equipment Operators- Underground Sewer & Water | Shovel , Excavator, Backhoe, Tractors Under 15 Metric Tons. | \$62.71 | 7A | 3K | 8X | View |
| Lewis | Power Equipment Operators- Underground Sewer & Water | Shovel, Excavator, Backhoe: Over 30 Metric Tons To 50 Metric Tons | \$63.76 | 7A | 3K | 8X | View |
| Lewis | Power Equipment Operators- Underground Sewer & Water | Shovel, Excavator, Backhoes, Tractors: 15 To 30 Metric Tons | \$63.20 | 7A | 3K | 8X | View |
| Lewis | Power Equipment Operators- Underground Sewer & Water | Shovel, Excavator, Backhoes: Over 50 Metric Tons To 90 Metric Tons | \$64.41 | 7A | 3K | 8X | View |
| Lewis | Power Equipment Operators- Underground Sewer & Water | Shovel, Excavator, Backhoes: Over 90 Metric Tons | \$65.06 | 7A | 3K | 8X | View |
| Lewis | Power Equipment Operators- Underground Sewer & Water | Slipform Pavers | \$63.76 | 7A | 3K | 8X | View |
| Lewis | Power Equipment Operators- Underground Sewer & Water | Spreader, Topsider & Screedman | \$63.76 | 7A | 3K | 8X | View |
| Lewis | Power Equipment Operators- Underground Sewer & Water | Subgrader Trimmer | \$63.20 | 7A | 3K | 8X | View |
| Lewis | Power Equipment Operators- Underground Sewer & Water | Tower Bucket Elevators | \$62.71 | 7A | 3K | 8X | View |
| Lewis | Power Equipment Operators- Underground Sewer & Water | Tower crane over 175' through 250' in height, base to boom | \$65.06 | 7A | 3K | 8X | View |
| Lewis | Power Equipment Operators- Underground Sewer & Water | Tower Crane: Up To 175' In Height, Base To Boom | \$64.41 | 7A | 3K | 8X | View |

| | | | | | | | |
|-------|--|--|---------|-----------|-----------|-----------|----------------------|
| | Sewer & Water | | | | | | |
| Lewis | Power Equipment Operators- Underground Sewer & Water | Transporters, All Track Or Truck Type | \$63.76 | <u>7A</u> | <u>3K</u> | <u>8X</u> | View |
| Lewis | Power Equipment Operators- Underground Sewer & Water | Trenching Machines | \$62.71 | <u>7A</u> | <u>3K</u> | <u>8X</u> | View |
| Lewis | Power Equipment Operators- Underground Sewer & Water | Truck Crane Oiler/driver - 100 Tons And Over | \$63.20 | <u>7A</u> | <u>3K</u> | <u>8X</u> | View |
| Lewis | Power Equipment Operators- Underground Sewer & Water | Truck Crane Oiler/driver Under 100 Tons | \$62.71 | <u>7A</u> | <u>3K</u> | <u>8X</u> | View |
| Lewis | Power Equipment Operators- Underground Sewer & Water | Truck Mount Portable Conveyor | \$63.20 | <u>7A</u> | <u>3K</u> | <u>8X</u> | View |
| Lewis | Power Equipment Operators- Underground Sewer & Water | Welder | \$63.76 | <u>7A</u> | <u>3K</u> | <u>8X</u> | View |
| Lewis | Power Equipment Operators- Underground Sewer & Water | Wheel Tractors, Farmall Type | \$59.98 | <u>7A</u> | <u>3K</u> | <u>8X</u> | View |
| Lewis | Power Equipment Operators- Underground Sewer & Water | Yo Yo Pay Dozer | \$63.20 | <u>7A</u> | <u>3K</u> | <u>8X</u> | View |
| Lewis | Power Line Clearance Tree Trimmers | Journey Level In Charge | \$49.96 | <u>5A</u> | <u>4A</u> | | View |
| Lewis | Power Line Clearance Tree Trimmers | Spray Person | \$47.37 | <u>5A</u> | <u>4A</u> | | View |
| Lewis | Power Line Clearance Tree Trimmers | Tree Equipment Operator | \$49.96 | <u>5A</u> | <u>4A</u> | | View |
| Lewis | Power Line Clearance Tree Trimmers | Tree Trimmer | \$44.57 | <u>5A</u> | <u>4A</u> | | View |
| Lewis | Power Line Clearance Tree Trimmers | Tree Trimmer Groundperson | \$33.60 | <u>5A</u> | <u>4A</u> | | View |
| Lewis | Refrigeration & Air Conditioning Mechanics | Journey Level | \$70.71 | <u>5A</u> | <u>1G</u> | | View |
| Lewis | Residential Brick Mason | Journey Level | \$21.96 | | <u>1</u> | | View |
| Lewis | Residential Carpenters | Journey Level | \$24.89 | | <u>1</u> | | View |
| Lewis | Residential Cement Masons | Journey Level | \$16.79 | | <u>1</u> | | View |
| Lewis | Residential Drywall Applicators | Journey Level | \$36.07 | | <u>1</u> | | View |
| Lewis | Residential Drywall Tapers | Journey Level | \$24.48 | | <u>1</u> | | View |
| Lewis | Residential Electricians | Journey Level | \$34.53 | <u>5A</u> | <u>1B</u> | | View |
| Lewis | Residential Glaziers | Journey Level | \$25.40 | | <u>1</u> | | View |
| Lewis | Residential Insulation Applicators | Journey Level | \$17.05 | | <u>1</u> | | View |
| Lewis | Residential Laborers | Journey Level | \$23.10 | | <u>1</u> | | View |
| Lewis | Residential Marble Setters | Journey Level | \$21.96 | | <u>1</u> | | View |
| Lewis | Residential Painters | Journey Level | \$18.76 | | <u>1</u> | | View |
| Lewis | Residential Plumbers & Pipefitters | Journey Level | \$26.35 | | <u>1</u> | | View |
| | | | | | | | |

| | | | | | | |
|-------|--|--------------------------------------|---------|-----------|-----------|----------------------|
| Lewis | Residential Refrigeration & Air Conditioning Mechanics | Journey Level | \$32.14 | | <u>1</u> | View |
| Lewis | Residential Sheet Metal Workers | Journey Level | \$33.28 | | <u>1</u> | View |
| Lewis | Residential Soft Floor Layers | Journey Level | \$14.86 | | <u>1</u> | View |
| Lewis | Residential Sprinkler Fitters (Fire Protection) | Journey Level | \$20.28 | | <u>1</u> | View |
| Lewis | Residential Stone Masons | Journey Level | \$21.96 | | <u>1</u> | View |
| Lewis | Residential Terrazzo Workers | Journey Level | \$14.86 | | <u>1</u> | View |
| Lewis | Residential Terrazzo/Tile Finishers | Journey Level | \$14.86 | | <u>1</u> | View |
| Lewis | Residential Tile Setters | Journey Level | \$14.86 | | <u>1</u> | View |
| Lewis | Roofers | Journey Level | \$52.87 | <u>5A</u> | <u>20</u> | View |
| Lewis | Roofers | Using Irritable Bituminous Materials | \$55.87 | <u>5A</u> | <u>20</u> | View |
| Lewis | Sheet Metal Workers | Journey Level (Field or Shop) | \$82.51 | <u>7F</u> | <u>1E</u> | View |
| Lewis | Sign Makers & Installers (Electrical) | Journey Level | \$18.04 | | <u>1</u> | View |
| Lewis | Sign Makers & Installers (Non-Electrical) | Journey Level | \$48.90 | <u>7A</u> | <u>3I</u> | View |
| Lewis | Soft Floor Layers | Journey Level | \$49.43 | <u>5A</u> | <u>3J</u> | View |
| Lewis | Solar Controls For Windows | Journey Level | \$12.00 | | <u>1</u> | View |
| Lewis | Sprinkler Fitters (Fire Protection) | Journey Level | \$61.68 | <u>7J</u> | <u>1R</u> | View |
| Lewis | Stage Rigging Mechanics (Non Structural) | Journey Level | \$13.23 | | <u>1</u> | View |
| Lewis | Stone Masons | Journey Level | \$57.32 | <u>5A</u> | <u>1M</u> | View |
| Lewis | Street And Parking Lot Sweeper Workers | Journey Level | \$16.00 | | <u>1</u> | View |
| Lewis | Surveyors | Chain Person | \$62.14 | <u>7A</u> | <u>3K</u> | View |
| Lewis | Surveyors | Instrument Person | \$62.71 | <u>7A</u> | <u>3K</u> | View |
| Lewis | Surveyors | Party Chief | \$63.76 | <u>7A</u> | <u>3K</u> | View |
| Lewis | Telecommunication Technicians | Journey Level | \$43.19 | <u>6Z</u> | <u>1B</u> | View |
| Lewis | Telephone Line Construction - Outside | Cable Splicer | \$41.22 | <u>5A</u> | <u>2B</u> | View |
| Lewis | Telephone Line Construction - Outside | Hole Digger/Ground Person | \$23.12 | <u>5A</u> | <u>2B</u> | View |
| Lewis | Telephone Line Construction - Outside | Installer (Repairer) | \$39.53 | <u>5A</u> | <u>2B</u> | View |
| Lewis | Telephone Line Construction - Outside | Special Aparatus Installer I | \$41.22 | <u>5A</u> | <u>2B</u> | View |
| Lewis | Telephone Line Construction - Outside | Special Apparatus Installer II | \$40.41 | <u>5A</u> | <u>2B</u> | View |
| Lewis | Telephone Line Construction - Outside | Telephone Equipment Operator (Heavy) | \$41.22 | <u>5A</u> | <u>2B</u> | View |
| Lewis | Telephone Line Construction - Outside | Telephone Equipment Operator (Light) | \$38.36 | <u>5A</u> | <u>2B</u> | View |
| Lewis | Telephone Line Construction - Outside | Telephone Lineperson | \$38.36 | <u>5A</u> | <u>2B</u> | View |

| | | | | | | | |
|-------|--|---------------------------------|---------|-----------|-----------|-----------|----------------------|
| Lewis | Telephone Line Construction - Outside | Television Groundperson | \$21.92 | <u>5A</u> | <u>2B</u> | | View |
| Lewis | Telephone Line Construction - Outside | Television Lineperson/Installer | \$29.13 | <u>5A</u> | <u>2B</u> | | View |
| Lewis | Telephone Line Construction - Outside | Television System Technician | \$34.68 | <u>5A</u> | <u>2B</u> | | View |
| Lewis | Telephone Line Construction - Outside | Television Technician | \$31.18 | <u>5A</u> | <u>2B</u> | | View |
| Lewis | Telephone Line Construction - Outside | Tree Trimmer | \$38.36 | <u>5A</u> | <u>2B</u> | | View |
| Lewis | Terrazzo Workers | Journey Level | \$52.61 | <u>5A</u> | <u>1M</u> | | View |
| Lewis | Tile Setters | Journey Level | \$52.61 | <u>5A</u> | <u>1M</u> | | View |
| Lewis | Tile, Marble & Terrazzo Finishers | Finisher | \$43.44 | <u>5A</u> | <u>1B</u> | | View |
| Lewis | Traffic Control Stripers | Journey Level | \$46.23 | <u>7A</u> | <u>1K</u> | | View |
| Lewis | Truck Drivers | Asphalt Mix Over 16 Yards | \$57.81 | <u>5D</u> | <u>3A</u> | <u>8L</u> | View |
| Lewis | Truck Drivers | Asphalt Mix To 16 Yards | \$56.97 | <u>5D</u> | <u>3A</u> | <u>8L</u> | View |
| Lewis | Truck Drivers | Dump Truck | \$56.97 | <u>5D</u> | <u>3A</u> | <u>8L</u> | View |
| Lewis | Truck Drivers | Dump Truck & Trailer | \$57.81 | <u>5D</u> | <u>3A</u> | <u>8L</u> | View |
| Lewis | Truck Drivers | Other Trucks | \$57.81 | <u>5D</u> | <u>3A</u> | <u>8L</u> | View |
| Lewis | Truck Drivers - Ready Mix | Transit Mix | \$57.81 | <u>5D</u> | <u>3A</u> | <u>8L</u> | View |
| Lewis | Well Drillers & Irrigation Pump Installers | Irrigation Pump Installer | \$18.18 | | <u>1</u> | | View |
| Lewis | Well Drillers & Irrigation Pump Installers | Oiler | \$12.00 | | <u>1</u> | | View |
| Lewis | Well Drillers & Irrigation Pump Installers | Well Driller | \$18.00 | | <u>1</u> | | View |

Washington State Department of Labor and Industries
Policy Statement
(Regarding the Production of "Standard" or "Non-standard" Items)

Below is the department's (State L&I's) list of criteria to be used in determining whether a prefabricated item is "standard" or "non-standard". For items not appearing on WSDOT's predetermined list, these criteria shall be used by the Contractor (and the Contractor's subcontractors, agents to subcontractors, suppliers, manufacturers, and fabricators) to determine coverage under RCW 39.12. The production, in the State of Washington, of non-standard items is covered by RCW 39.12, and the production of standard items is not. The production of any item outside the State of Washington is not covered by RCW 39.12.

1. Is the item fabricated for a public works project? If not, it is not subject to RCW 39.12. If it is, go to question 2.
2. Is the item fabricated on the public works jobsite? If it is, the work is covered under RCW 39.12. If not, go to question 3.
3. Is the item fabricated in an assembly/fabrication plant set up for, and dedicated primarily to, the public works project? If it is, the work is covered by RCW 39.12. If not, go to question 4.
4. Does the item require any assembly, cutting, modification or other fabrication by the supplier? If not, the work is not covered by RCW 39.12. If yes, go to question 5.
5. Is the prefabricated item intended for the public works project typically an inventory item which could reasonably be sold on the general market? If not, the work is covered by RCW 39.12. If yes, go to question 6.
6. Does the specific prefabricated item, generally defined as standard, have any unusual characteristics such as shape, type of material, strength requirements, finish, etc? If yes, the work is covered under RCW 39.12.

Any firm with questions regarding the policy, WSDOT's Predetermined List, or for determinations of covered and non-covered workers shall be directed to State L&I at (360) 902-5330.

**WSDOT's
Predetermined List for
Suppliers - Manufactures - Fabricator**

Below is a list of potentially prefabricated items, originally furnished by WSDOT to Washington State Department of Labor and Industries, that may be considered non-standard and therefore covered by the prevailing wage law, RCW 39.12. Items marked with an X in the "YES" column should be considered to be non-standard and therefore covered by RCW 39.12. Items marked with an X in the "NO" column should be considered to be standard and therefore not covered. Of course, exceptions to this general list may occur, and in that case shall be evaluated according to the criteria described in State and L&I's policy statement.

| ITEM DESCRIPTION | YES | NO |
|---|------------|-----------|
| 1. Metal rectangular frames, solid metal covers, herringbone grates, and bi-directional vaned grates for Catch Basin Types 1, 1L, 1P, and 2 and Concrete Inlets. See Std. Plans | | X |
| 2. Metal circular frames (rings) and covers, circular grates, and prefabricated ladders for Manhole Types 1, 2, and 3, Drywell Types 1, 2, and 3 and Catch Basin Type 2. See Std. Plans | | X |
| 3. Prefabricated steel grate supports and welded grates, metal frames and dual vaned grates, and Type 1, 2, and 3 structural tubing grates for Drop Inlets. See Std. Plans. | | X |
| 4. Concrete Pipe - Plain Concrete pipe and reinforced concrete pipe Class 2 to 5 sizes smaller than 60 inch diameter. | | X |
| 5. Concrete Pipe - Plain Concrete pipe and reinforced concrete pipe Class 2 to 5 sizes larger than 60 inch diameter. | | X |
| 6. Corrugated Steel Pipe - Steel lock seam corrugated pipe for culverts and storm sewers, sizes 30 inch to 120 inches in diameter. May also be treated, 1 thru 5. | | X |
| 7. Corrugated Aluminum Pipe - Aluminum lock seam corrugated pipe for culverts and storm sewers, sizes 30 inch to 120 inches in diameter. May also be treated, #5. | | X |

| ITEM DESCRIPTION | YES | NO |
|---|----------|----------|
| 8. Anchor Bolts & Nuts - Anchor Bolts and Nuts, for mounting sign structures, luminaries and other items, shall be made from commercial bolt stock. See Contract Plans and Std. Plans for size and material type. | | X |
| 9. Aluminum Pedestrian Handrail - Pedestrian handrail conforming to the type and material specifications set forth in the contract plans. Welding of aluminum shall be in accordance with Section 9-28.14(3). | X | |
| 10. Major Structural Steel Fabrication - Fabrication of major steel items such as trusses, beams, girders, etc., for bridges. | X | |
| 11. Minor Structural Steel Fabrication - Fabrication of minor steel Items such as special hangers, brackets, access doors for structures, access ladders for irrigation boxes, bridge expansion joint systems, etc., involving welding, cutting, punching and/or boring of holes. See Contact Plans for item description and shop drawings. | X | |
| 12. Aluminum Bridge Railing Type BP - Metal bridge railing conforming to the type and material specifications set forth in the Contract Plans. Welding of aluminum shall be in accordance with Section 9-28.14(3). | | X |
| 13. Concrete Piling--Precast-Prestressed concrete piling for use as 55 and 70 ton concrete piling. Concrete to conform to Section 9-19.1 of Std. Spec.. | X | |
| 14. Precast Manhole Types 1, 2, and 3 with cones, adjustment sections and flat top slabs. See Std. Plans. | | X |
| 15. Precast Drywell Types 1, 2, and with cones and adjustment Sections. See Std. Plans. | | X |
| 16. Precast Catch Basin - Catch Basin type 1, 1L, 1P, and 2 With adjustment sections. See Std. Plans. | | X |

| ITEM DESCRIPTION | YES | NO |
|--|------------|-----------|
| 17. Precast Concrete Inlet - with adjustment sections, See Std. Plans | | X |
| 18. Precast Drop Inlet Type 1 and 2 with metal grate supports. See Std. Plans. | | X |
| 19. Precast Grate Inlet Type 2 with extension and top units. See Std. Plans | | X |
| 20. Metal frames, vaned grates, and hoods for Combination Inlets. See Std. Plans | | X |
| 21. Precast Concrete Utility Vaults - Precast Concrete utility vaults of various sizes. Used for in ground storage of utility facilities and controls. See Contract Plans for size and construction requirements. Shop drawings are to be provided for approval prior to casting | | X |
| 22. Vault Risers - For use with Valve Vaults and Utilities X Vaults. | | X |
| 23. Valve Vault - For use with underground utilities. See Contract Plans for details. | | X |
| 24. Precast Concrete Barrier - Precast Concrete Barrier for use as new barrier or may also be used as Temporary Concrete Barrier. Only new state approved barrier may be used as permanent barrier. | | X |
| 25. Reinforced Earth Wall Panels – Reinforced Earth Wall Panels in size and shape as shown in the Plans. Fabrication plant has annual approval for methods and materials to be used. See Shop Drawing. Fabrication at other locations may be approved, after facilities inspection, contact HQ. Lab. | X | |
| 26. Precast Concrete Walls - Precast Concrete Walls - tilt-up wall panel in size and shape as shown in Plans. Fabrication plant has annual approval for methods and materials to be used | X | |

| ITEM DESCRIPTION | YES | NO |
|---|----------|----------|
| 27. Precast Railroad Crossings - Concrete Crossing Structure Slabs. | X | |
| 28. 12, 18 and 26 inch Standard Precast Prestressed Girder – Standard Precast Prestressed Girder for use in structures. Fabricator plant has annual approval of methods and materials to be used. Shop Drawing to be provided for approval prior to casting girders. See Std. Spec. Section 6-02.3(25)A | X | |
| 29. Prestressed Concrete Girder Series 4-14 - Prestressed Concrete Girders for use in structures. Fabricator plant has annual approval of methods and materials to be used. Shop Drawing to be provided for approval prior to casting girders. See Std. Spec. Section 6-02.3(25)A | X | |
| 30. Prestressed Tri-Beam Girder - Prestressed Tri-Beam Girders for use in structures. Fabricator plant has annual approval of methods and materials to be used. Shop Drawing to be provided for approval prior to casting girders. See Std. Spec. Section 6-02.3(25)A | X | |
| 31. Prestressed Precast Hollow-Core Slab – Precast Prestressed Hollow-core slab for use in structures. Fabricator plant has annual approval of methods and materials to be used. Shop Drawing to be provided for approval prior to casting girders. See Std. Spec. Section 6-02.3(25)A. | X | |
| 32. Prestressed-Bulb Tee Girder - Bulb Tee Prestressed Girder for use in structures. Fabricator plant has annual approval of methods and materials to be used. Shop Drawing to be provided for approval prior to casting girders. See Std. Spec. Section 6-02.3(25)A | X | |
| 33. Monument Case and Cover See Std. Plan. | | X |

| ITEM DESCRIPTION | YES | NO |
|---|----------|----------|
| 34. Cantilever Sign Structure - Cantilever Sign Structure fabricated from steel tubing meeting AASHTO-M-183. See Std. Plans, and Contract Plans for details. The steel structure shall be galvanized after fabrication in accordance with AASHTO-M-111. | X | |
| 35. Mono-tube Sign Structures - Mono-tube Sign Bridge fabricated to details shown in the Plans. Shop drawings for approval are required prior to fabrication. | X | |
| 36. Steel Sign Bridges - Steel Sign Bridges fabricated from steel tubing meeting AASHTO-M-138 for Aluminum Alloys. See Std. Plans, and Contract Plans for details. The steel structure shall be galvanized after fabrication in accordance with AASHTO-M-111. | X | |
| 37. Steel Sign Post - Fabricated Steel Sign Posts as detailed in Std Plans. Shop drawings for approval are to be provided prior to fabrication | | X |
| 38. Light Standard-Prestressed - Spun, prestressed, hollow concrete poles. | X | |
| 39. Light Standards - Lighting Standards for use on highway illumination systems, poles to be fabricated to conform with methods and materials as specified on Std. Plans. See Special Provisions for pre-approved drawings. | X | |
| 40. Traffic Signal Standards - Traffic Signal Standards for use on highway and/or street signal systems. Standards to be fabricated to conform with methods and material as specified on Std. Plans. See Special Provisions for pre-approved drawings | X | |
| 41. Precast Concrete Sloped Mountable Curb (Single and DualFaced) See Std. Plans. | | X |

| ITEM DESCRIPTION | YES | NO |
|--|----------------------------|---------------------|
| 42. Traffic Signs - Prior to approval of a Fabricator of Traffic Signs, the sources of the following materials must be submitted and approved for reflective sheeting, legend material, and aluminum sheeting. NOTE: *** Fabrication inspection required. Only signs tagged "Fabrication Approved" by WSDOT Sign Fabrication Inspector to be installed | X | X |
| | Custom Message | Std Signing Message |
| 43. Cutting & bending reinforcing steel | | X |
| 44. Guardrail components | X | X |
| | Custom End Sec | Standard Sec |
| 45. Aggregates/Concrete mixes | Covered by WAC 296-127-018 | |
| 46. Asphalt | Covered by WAC 296-127-018 | |
| 47. Fiber fabrics | | X |
| 48. Electrical wiring/components | | X |
| 49. treated or untreated timber pile | | X |
| 50. Girder pads (elastomeric bearing) | X | |
| 51. Standard Dimension lumber | | X |
| 52. Irrigation components | | X |

| ITEM DESCRIPTION | YES | NO |
|--|----------|----------|
| 53. Fencing materials | | X |
| 54. Guide Posts | | X |
| 55. Traffic Buttons | | X |
| 56. Epoxy | | X |
| 57. Cribbing | | X |
| 58. Water distribution materials | | X |
| 59. Steel "H" piles | | X |
| 60. Steel pipe for concrete pile casings | | X |
| 61. Steel pile tips, standard | | X |
| 62. Steel pile tips, custom | X | |

Prefabricated items specifically produced for public works projects that are prefabricated in a county other than the county wherein the public works project is to be completed, the wage for the offsite prefabrication shall be the applicable prevailing wage for the county in which the actual prefabrication takes place.

It is the manufacturer of the prefabricated product to verify that the correct county wage rates are applied to work they perform.

See RCW [39.12.010](#)

(The definition of "locality" in RCW [39.12.010](#)(2) contains the phrase "wherein the physical work is being performed." The department interprets this phrase to mean the actual work site.

WSDOT's List of State Occupations not applicable to Heavy and Highway Construction Projects

This project is subject to the state hourly minimum rates for wages and fringe benefits in the contract provisions, as provided by the state Department of Labor and Industries.

The following list of occupations, is comprised of those occupations that are not normally used in the construction of heavy and highway projects.

When considering job classifications for use and / or payment when bidding on, or building heavy and highway construction projects for, or administered by WSDOT, these Occupations will be excepted from the included "Washington State Prevailing Wage Rates For Public Work Contracts" documents.

- Building Service Employees
- Electrical Fixture Maintenance Workers
- Electricians - Motor Shop
- Heating Equipment Mechanics
- Industrial Engine and Machine Mechanics
- Industrial Power Vacuum Cleaners
- Inspection, Cleaning, Sealing of Water Systems by Remote Control
- Laborers - Underground Sewer & Water
- Machinists (Hydroelectric Site Work)
- Modular Buildings
- Playground & Park Equipment Installers
- Power Equipment Operators - Underground Sewer & Water
- Residential *** ALL ASSOCIATED RATES ***
- Sign Makers and Installers (Non-Electrical)
- Sign Makers and Installers (Electrical)
- Stage Rigging Mechanics (Non Structural)

The following occupations may be used only as outlined in the preceding text concerning "WSDOT's list for Suppliers - Manufacturers - Fabricators"

- Fabricated Precast Concrete Products
- Metal Fabrication (In Shop)

Definitions for the Scope of Work for prevailing wages may be found at the Washington State Department of Labor and Industries web site and in WAC Chapter 296-127.

**Washington State Department of Labor and Industries
Policy Statements
(Regarding Production and Delivery of Gravel, Concrete, Asphalt, etc.)**

WAC 296-127-018 Agency filings affecting this section

Coverage and exemptions of workers involved in the production and delivery of gravel, concrete, asphalt, or similar materials.

(1) The materials covered under this section include but are not limited to: Sand, gravel, crushed rock, concrete, asphalt, or other similar materials.

(2) All workers, regardless of by whom employed, are subject to the provisions of chapter 39.12 RCW when they perform any or all of the following functions:

(a) They deliver or discharge any of the above-listed materials to a public works project site:

(i) At one or more point(s) directly upon the location where the material will be incorporated into the project; or

(ii) At multiple points at the project; or

(iii) Adjacent to the location and coordinated with the incorporation of those materials.

(b) They wait at or near a public works project site to perform any tasks subject to this section of the rule.

(c) They remove any materials from a public works construction site pursuant to contract requirements or specifications (e.g., excavated materials, materials from demolished structures, clean-up materials, etc.).

(d) They work in a materials production facility (e.g., batch plant, borrow pit, rock quarry, etc.) which is established for a public works project for the specific, but not necessarily exclusive, purpose of supplying materials for the project.

(e) They deliver concrete to a public works site regardless of the method of incorporation.

(f) They assist or participate in the incorporation of any materials into the public works project.

(3) All travel time that relates to the work covered under subsection (2) of this section requires the payment of prevailing wages. Travel time includes time spent waiting to load, loading, transporting, waiting to unload, and delivering materials. Travel time would include all time spent in travel in support of a public works project whether the vehicle is empty or full. For example, travel time spent returning to a supply source to obtain another load of material for use on a public works site or returning to the public works site to obtain another load of excavated material is time spent in travel that is subject to prevailing wage. Travel to a supply source, including travel from a public works site, to obtain materials for use on a private project would not be travel subject to the prevailing wage.

(4) Workers are not subject to the provisions of chapter 39.12 RCW when they deliver materials to a stockpile.

(a) A "stockpile" is defined as materials delivered to a pile located away from the site of incorporation such that the stockpiled materials must be physically moved from the stockpile and transported to another location on the project site in order to be incorporated into the project.

(b) A stockpile does not include any of the functions described in subsection (2)(a) through (f) of this section; nor does a stockpile include materials delivered or distributed to multiple locations upon the project site; nor does a stockpile include materials dumped at the place of incorporation, or adjacent to the location and coordinated with the incorporation.

(5) The applicable prevailing wage rate shall be determined by the locality in which the work is performed. Workers subject to subsection (2)(d) of this section, who produce such materials at an off-site facility shall be paid the applicable prevailing wage rates for the county in which the off-site facility is located. Workers subject to subsection (2) of this section, who deliver such materials to a public works project site shall be paid the applicable prevailing wage rates for the county in which the public works project is located.

[Statutory Authority: Chapter 39.12 RCW, RCW 43.22.051 and 43.22.270. 08-24-101, § 296-127-018, filed 12/2/08, effective 1/2/09. Statutory Authority: Chapters 39.04 and 39.12 RCW and RCW 43.22.270. 92-01-104 and 92-08-101, § 296-127-018, filed 12/18/91 and 4/1/92, effective 8/31/92.]

Benefit Code Key – Effective 3/3/2019 thru 8/30/2019

Overtime Codes

Overtime calculations are based on the hourly rate actually paid to the worker. On public works projects, the hourly rate must be not less than the prevailing rate of wage minus the hourly rate of the cost of fringe benefits actually provided for the worker.

1. ALL HOURS WORKED IN EXCESS OF EIGHT (8) HOURS PER DAY OR FORTY (40) HOURS PER WEEK SHALL BE PAID AT ONE AND ONE-HALF TIMES THE HOURLY RATE OF WAGE.
 - B. All hours worked on Saturdays shall be paid at one and one-half times the hourly rate of wage. All hours worked on Sundays and holidays shall be paid at double the hourly rate of wage.
 - C. The first two (2) hours after eight (8) regular hours Monday through Friday and the first ten (10) hours on Saturday shall be paid at one and one-half times the hourly rate of wage. All other overtime hours and all hours worked on Sundays and holidays shall be paid at double the hourly rate of wage.
 - D. The first two (2) hours before or after a five-eight (8) hour workweek day or a four-ten (10) hour workweek day and the first eight (8) hours worked the next day after either workweek shall be paid at one and one-half times the hourly rate of wage. All additional hours worked and all worked on Sundays and holidays shall be paid at double the hourly rate of wage.
 - E. The first two (2) hours after eight (8) regular hours Monday through Friday and the first eight (8) hours on Saturday shall be paid at one and one-half times the hourly rate of wage. All other hours worked Monday through Saturday, and all hours worked on Sundays and holidays shall be paid at double the hourly rate of wage.
 - F. The first two (2) hours after eight (8) regular hours Monday through Friday and the first ten (10) hours on Saturday shall be paid at one and one-half times the hourly rate of wage. All other overtime hours worked, except Labor Day, shall be paid at double the hourly rate of wage. All hours worked on Labor Day shall be paid at three times the hourly rate of wage.
 - G. The first ten (10) hours worked on Saturdays and the first ten (10) hours worked on a fifth calendar weekday in a four-ten hour schedule, shall be paid at one and one-half times the hourly rate of wage. All hours worked in excess of ten (10) hours per day Monday through Saturday and all hours worked on Sundays and holidays shall be paid at double the hourly rate of wage.
 - H. All hours worked on Saturdays (except makeup days if work is lost due to inclement weather conditions or equipment breakdown) shall be paid at one and one-half times the hourly rate of wage. All hours worked Monday through Saturday over twelve (12) hours and all hours worked on Sundays and holidays shall be paid at double the hourly rate of wage.
 - I. All hours worked on Sundays and holidays shall also be paid at double the hourly rate of wage.
 - J. The first two (2) hours after eight (8) regular hours Monday through Friday and the first ten (10) hours on Saturday shall be paid at one and one-half times the hourly rate of wage. All hours worked over ten (10) hours Monday through Saturday, Sundays and holidays shall be paid at double the hourly rate of wage.
 - K. All hours worked on Saturdays and Sundays shall be paid at one and one-half times the hourly rate of wage. All hours worked on holidays shall be paid at double the hourly rate of wage.
 - M. All hours worked on Saturdays (except makeup days if work is lost due to inclement weather conditions) shall be paid at one and one-half times the hourly rate of wage. All hours worked on Sundays and holidays shall be paid at double the hourly rate of wage.
 - N. All hours worked on Saturdays (except makeup days) shall be paid at one and one-half times the hourly rate of wage. All hours worked on Sundays and holidays shall be paid at double the hourly rate of wage.

Overtime Codes Continued

1. O. The first ten (10) hours worked on Saturday shall be paid at one and one-half times the hourly rate of wage. All hours worked on Sundays, holidays and after twelve (12) hours, Monday through Friday and after ten (10) hours on Saturday shall be paid at double the hourly rate of wage.
- P. All hours worked on Saturdays (except makeup days if circumstances warrant) and Sundays shall be paid at one and one-half times the hourly rate of wage. All hours worked on holidays shall be paid at double the hourly rate of wage.
- Q. The first two (2) hours after eight (8) regular hours Monday through Friday and up to ten (10) hours worked on Saturdays shall be paid at one and one-half times the hourly rate of wage. All hours worked in excess of ten (10) hours per day Monday through Saturday and all hours worked on Sundays and holidays (except Christmas day) shall be paid at double the hourly rate of wage. All hours worked on Christmas day shall be paid at two and one-half times the hourly rate of wage.
- R. All hours worked on Sundays and holidays shall be paid at two times the hourly rate of wage.
- S. The first two (2) hours after eight (8) regular hours Monday through Friday and the first eight (8) hours on Saturday shall be paid at one and one-half times the hourly rate of wage. All hours worked on holidays and all other overtime hours worked, except Labor Day, shall be paid at double the hourly rate of wage. All hours worked on Labor Day shall be paid at three times the hourly rate of wage.
- U. All hours worked on Saturdays shall be paid at one and one-half times the hourly rate of wage. All hours worked on Sundays and holidays (except Labor Day) shall be paid at two times the hourly rate of wage. All hours worked on Labor Day shall be paid at three times the hourly rate of wage.
- V. All hours worked on Sundays and holidays (except Thanksgiving Day and Christmas day) shall be paid at one and one-half times the hourly rate of wage. All hours worked on Thanksgiving Day and Christmas day shall be paid at double the hourly rate of wage.
- W. All hours worked on Saturdays and Sundays (except make-up days due to conditions beyond the control of the employer)) shall be paid at one and one-half times the hourly rate of wage. All hours worked on holidays shall be paid at double the hourly rate of wage.
- X. The first four (4) hours after eight (8) regular hours Monday through Friday and the first twelve (12) hours on Saturday shall be paid at one and one-half times the hourly rate of wage. All hours worked over twelve (12) hours Monday through Saturday, Sundays and holidays shall be paid at double the hourly rate of wage. When holiday falls on Saturday or Sunday, the day before Saturday, Friday, and the day after Sunday, Monday, shall be considered the holiday and all work performed shall be paid at double the hourly rate of wage.
- Y. All hours worked outside the hours of 5:00 am and 5:00 pm (or such other hours as may be agreed upon by any employer and the employee) and all hours worked in excess of eight (8) hours per day (10 hours per day for a 4 x 10 workweek) and on Saturdays and holidays (except labor day) shall be paid at one and one-half times the hourly rate of wage. (except for employees who are absent from work without prior approval on a scheduled workday during the workweek shall be paid at the straight-time rate until they have worked 8 hours in a day (10 in a 4 x 10 workweek) or 40 hours during that workweek.) All hours worked Monday through Saturday over twelve (12) hours and all hours worked on Sundays and Labor Day shall be paid at double the hourly rate of wage.
- Z. All hours worked on Saturdays and Sundays shall be paid at one and one-half times the hourly rate of wage. All hours worked on holidays shall be paid the straight time rate of pay in addition to holiday pay.

Overtime Codes Continued

2. ALL HOURS WORKED IN EXCESS OF EIGHT (8) HOURS PER DAY OR FORTY (40) HOURS PER WEEK SHALL BE PAID AT ONE AND ONE-HALF TIMES THE HOURLY RATE OF WAGE.
- B. All hours worked on holidays shall be paid at one and one-half times the hourly rate of wage.
 - C. All hours worked on Sundays shall be paid at one and one-half times the hourly rate of wage. All hours worked on holidays shall be paid at two times the hourly rate of wage.
 - F. The first eight (8) hours worked on holidays shall be paid at the straight hourly rate of wage in addition to the holiday pay. All hours worked in excess of eight (8) hours on holidays shall be paid at double the hourly rate of wage.
 - G. All hours worked on Sunday shall be paid at two times the hourly rate of wage. All hours worked on paid holidays shall be paid at two and one-half times the hourly rate of wage including holiday pay.
 - H. All hours worked on Sunday shall be paid at two times the hourly rate of wage. All hours worked on holidays shall be paid at one and one-half times the hourly rate of wage.
 - O. All hours worked on Sundays and holidays shall be paid at one and one-half times the hourly rate of wage.
 - R. All hours worked on Sundays and holidays and all hours worked over sixty (60) in one week shall be paid at double the hourly rate of wage.
 - U. All hours worked on Saturdays shall be paid at one and one-half times the hourly rate of wage. All hours worked over 12 hours in a day or on Sundays and holidays shall be paid at double the hourly rate of wage.
 - W. The first two (2) hours after eight (8) regular hours Monday through Friday and the first eight (8) hours on Saturday shall be paid at one and one-half times the hourly rate of wage. All other hours worked Monday through Saturday, and all hours worked on Sundays and holidays shall be paid at double the hourly rate of wage. On a four-day, ten-hour weekly schedule, either Monday thru Thursday or Tuesday thru Friday schedule, all hours worked after ten shall be paid at double the hourly rate of wage. The first eight (8) hours worked on the fifth day shall be paid at one and one-half times the hourly rate of wage. All other hours worked on the fifth, sixth, and seventh days and on holidays shall be paid at double the hourly rate of wage.
3. ALL HOURS WORKED IN EXCESS OF EIGHT (8) HOURS PER DAY OR FORTY (40) HOURS PER WEEK SHALL BE PAID AT ONE AND ONE-HALF TIMES THE HOURLY RATE OF WAGE.
- A. Work performed in excess of eight (8) hours of straight time per day, or ten (10) hours of straight time per day when four ten (10) hour shifts are established, or forty (40) hours of straight time per week, Monday through Friday, or outside the normal shift, and all work on Saturdays shall be paid at time and one-half the straight time rate. Hours worked over twelve hours (12) in a single shift and all work performed after 6:00 pm Saturday to 6:00 am Monday and holidays shall be paid at double the straight time rate of pay. Any shift starting between the hours of 6:00 pm and midnight shall receive an additional one dollar (\$1.00) per hour for all hours worked that shift. The employer shall have the sole discretion to assign overtime work to employees. Primary consideration for overtime work shall be given to employees regularly assigned to the work to be performed on overtime situations. After an employee has worked eight (8) hours at an applicable overtime rate, all additional hours shall be at the applicable overtime rate until such time as the employee has had a break of eight (8) hours or more.
 - C. Work performed in excess of eight (8) hours of straight time per day, or ten (10) hours of straight time per day when four ten (10) hour shifts are established, or forty (40) hours of straight time per week, Monday through Friday, or outside the normal shift, and all work on Saturdays shall be paid at one and one-half times the hourly rate of wage. All work performed after 6:00 pm Saturday to 5:00 am Monday and Holidays shall be paid at double the hourly rate of wage. After an employee has worked eight (8) hours at an applicable overtime rate, all additional hours shall be at the applicable overtime rate until such time as the employee has had a break of eight (8) hours or more.

Overtime Codes Continued

3. E. All hours worked Sundays and holidays shall be paid at double the hourly rate of wage. Each week, once 40 hours of straight time work is achieved, then any hours worked over 10 hours per day Monday through Saturday shall be paid at double the hourly wage rate.
- F. All hours worked on Saturday shall be paid at one and one-half times the hourly rate of wage. All hours worked on Sunday shall be paid at two times the hourly rate of wage. All hours worked on paid holidays shall be paid at two and one-half times the hourly rate of wage including holiday pay.
- H. All work performed on Sundays between March 16th and October 14th and all Holidays shall be compensated for at two (2) times the regular rate of pay. Work performed on Sundays between October 15th and March 15th shall be compensated at one and one half (1-1/2) times the regular rate of pay.
- I. All hours worked on Saturdays shall be paid at one and one-half times the hourly rate of wage. In the event the job is down due to weather conditions during a five day work week (Monday through Friday,) or a four day-ten hour work week (Tuesday through Friday,) then Saturday may be worked as a voluntary make-up day at the straight time rate. However, Saturday shall not be utilized as a make-up day when a holiday falls on Friday. All hours worked Monday through Saturday over twelve (12) hours and all hours worked on Sundays and holidays shall be paid at double the hourly rate of wage.
- J. All hours worked between the hours of 10:00 pm and 5:00 am, Monday through Friday, and all hours worked on Saturdays shall be paid at a one and one-half times the hourly rate of wage. All hours worked on Sundays and holidays shall be paid at double the hourly rate of wage.
- K. Work performed in excess of eight (8) hours of straight time per day, or ten (10) hours of straight time per day when four ten (10) hour shifts are established, or forty (40) hours of straight time per week, Monday through Friday, or outside the normal 5 am to 6pm shift, and all work on Saturdays shall be paid at one and one-half times the hourly rate of wage. All work performed after 6:00 pm Saturday to 5:00 am Monday and Holidays, and all hours worked in excess of twelve (12) hours in a single shift shall be paid at double the hourly rate of wage.

After an employee has worked eight (8) hours at an applicable overtime rate, all additional hours shall be at the applicable overtime rate until such time as the employee has had a break of eight (8) hours or more. When an employee returns to work without at least eight (8) hours time off since their previous shift, all such time shall be a continuation of shift and paid at the applicable overtime rate until he/she shall have the eight (8) hours rest period.

4. ALL HOURS WORKED IN EXCESS OF EIGHT (8) HOURS PER DAY OR FORTY (40) HOURS PER WEEK SHALL BE PAID AT ONE AND ONE-HALF TIMES THE HOURLY RATE OF WAGE.
- A. All hours worked in excess of eight (8) hours per day or forty (40) hours per week shall be paid at double the hourly rate of wage. All hours worked on Saturdays, Sundays and holidays shall be paid at double the hourly rate of wage.
- B. All hours worked over twelve (12) hours per day and all hours worked on holidays shall be paid at double the hourly rate of wage.
- C. On Monday through Friday, the first four (4) hours of overtime after eight (8) hours of straight time work shall be paid at one and one half (1-1/2) times the straight time rate of pay, unless a four (4) day ten (10) hour workweek has been established. On a four (4) day ten (10) hour workweek scheduled Monday through Thursday, or Tuesday through Friday, the first two (2) hours of overtime after ten (10) hours of straight time work shall be paid at one and one half (1-1/2) times the straight time rate of pay. On Saturday, the first twelve (12) hours of work shall be paid at one and one half (1-1/2) times the straight time rate of pay, except that if the job is down on Monday through Friday due to weather conditions or other conditions outside the control of the employer, the first ten (10) hours on Saturday may be worked at the straight time rate of pay. All hours worked over twelve (12) hours in a day and all hours worked on Sunday and Holidays shall be paid at two (2) times the straight time rate of pay.

Overtime Codes Continued

4. D. All hours worked in excess of eight (8) hours per day or forty (40) hours per week shall be paid at double the hourly rate of wage. All hours worked on Saturday, Sundays and holidays shall be paid at double the hourly rate of pay. Rates include all members of the assigned crew.

EXCEPTION:

On all multipole structures and steel transmission lines, switching stations, regulating, capacitor stations, generating plants, industrial plants, associated installations and substations, except those substations whose primary function is to feed a distribution system, will be paid overtime under the following rates:

The first two (2) hours after eight (8) regular hours Monday through Friday of overtime on a regular workday, shall be paid at one and one-half times the hourly rate of wage. All hours in excess of ten (10) hours will be at two (2) times the hourly rate of wage. The first eight (8) hours worked on Saturday will be paid at one and one-half (1-1/2) times the hourly rate of wage. All hours worked in excess of eight (8) hours on Saturday, and all hours worked on Sundays and holidays will be at the double the hourly rate of wage.

All overtime eligible hours performed on the above described work that is energized, shall be paid at the double the hourly rate of wage.

- E. The first two (2) hours after eight (8) regular hours Monday through Friday and the first eight (8) hours on Saturday shall be paid at one and one-half times the hourly rate of wage. All other hours worked Monday through Saturday, and all hours worked on Sundays and holidays shall be paid at double the hourly rate of wage.

On a four-day, ten-hour weekly schedule, either Monday thru Thursday or Tuesday thru Friday schedule, all hours worked after ten shall be paid at double the hourly rate of wage. The Monday or Friday not utilized in the normal four-day, ten hour work week, and Saturday shall be paid at one and one half (1½) times the regular shift rate for the first eight (8) hours. All other hours worked Monday through Saturday, and all hours worked on Sundays and holidays shall be paid at double the hourly rate of wage.

- F. All hours worked between the hours of 6:00 pm and 6:00 am, Monday through Saturday, shall be paid at a premium rate of 20% over the hourly rate of wage. All hours worked on Sundays shall be paid at one and one-half times the hourly rate of wage. All hours worked on holidays shall be paid at double the hourly rate of wage.

- G. All hours worked on Saturdays shall be paid at one and one-half times the hourly rate of wage. All hours worked Monday through Saturday over twelve (12) hours and all hours worked on Sundays and holidays shall be paid at double the hourly rate of wage.

- H. The first two (2) hours after eight (8) regular hours Monday through Friday and the first eight (8) hours on Saturday shall be paid at one and one-half times the hourly rate of wage. All other overtime hours worked, except Labor Day, and all hours on Sunday shall be paid at double the hourly rate of wage. All hours worked on Labor Day shall be paid at three times the hourly rate of wage.

- I. The First eight (8) hours worked on Saturdays shall be paid at one and one-half times the hourly rate of wage. All hours worked in excess of eight (8) per day on Saturdays shall be paid at double the hourly rate of wage. All hours worked on Sundays and holidays shall be paid at double the hourly rate of wage.

- J. The first eight (8) hours worked on a Saturday shall be paid at one and one-half times the hourly rate of wage. All hours worked in excess of eight (8) hours on a Saturday shall be paid at double the hourly rate of wage. All hours worked over twelve (12) in a day, and all hours worked on Sundays and Holidays shall be paid at double the hourly rate of wage.

- K. All hours worked on a Saturday shall be paid at one and one-half times the hourly rate of wage, so long as Saturday is the sixth consecutive day worked. All hours worked over twelve (12) in a day Monday through Saturday, and all hours worked on Sundays and Holidays shall be paid at double the hourly rate of wage.

Benefit Code Key – Effective 3/3/2019 thru 8/30/2019

4. L. The first twelve (12) hours worked on a Saturday shall be paid at one and one-half times the hourly rate of wage. All hours worked on a Saturday in excess of twelve (12) hours shall be paid at double the hourly rate of pay. All hours worked over twelve (12) in a day Monday through Friday, and all hours worked on Sundays shall be paid at double the hourly rate of wage. All hours worked on a holiday shall be paid at one and one-half times the hourly rate of wage, except that all hours worked on Labor Day shall be paid at double the hourly rate of pay.
- M. All hours worked on Sunday and Holidays shall be paid at double the hourly rate. Any employee reporting to work less than nine (9) hours from their previous quitting time shall be paid for such time at time and one-half times the hourly rate.
- N. All hours worked on Saturdays shall be paid at one and one-half times the hourly rate of wage. All hours worked on Sundays and holidays, and all work performed between the hours of midnight (12:00 AM) and eight AM (8:00 AM) every day shall be paid at double the hourly rate of wage.
- O. All hours worked between midnight Friday to midnight Sunday shall be paid at one and one-half the hourly rate of wage. After an employee has worked in excess of eight (8) continuous hours in any one or more calendar days, all additional hours shall be at the applicable overtime rate until such time as the employee has had a break of six (6) hours or more. All hours worked on Holidays shall be paid at double the hourly rate of wage.
- P. All hours worked on Holidays shall be paid at one and one-half times the hourly rate of wage.
- Q. The first four (4) hours after eight (8) regular hours Monday through Friday and the first eight (8) hours on Saturday shall be paid at one and one-half times the hourly rate of wage. All hours worked over twelve (12) hours Monday through Saturday shall be paid at double the hourly rate. All hours worked on Sundays and holidays shall be paid at double the hourly rate of wage.
- R. All hours worked on Saturdays shall be paid at one and one-half times the hourly rate of wage, so long as Saturday is the sixth consecutive day worked. All hours worked on Sundays and holidays shall be paid at double the hourly rate of wage.
- S. All hours worked on Saturdays and Holidays shall be paid at one and one-half times the hourly rate of wage. All hours worked on Sundays shall be paid at double the hourly rate of wage.
- T. The first two (2) hours of overtime for hours worked Monday-Friday shall be paid at one and one-half times the hourly rate of wage. All hours worked in excess of ten (10) hours per day shall be paid at double the hourly rate of wage. All hours worked on Sundays and holidays shall be paid at double the hourly rate of wage. For work on Saturday which is scheduled prior to the end of shift on Friday, the first six (6) hours work shall be paid at one and one-half times the hourly rate of wage, and all hours over (6) shall be paid double the hourly rate of wage. For work on Saturday which was assigned following the close of shift on Friday, all work shall be paid at double the hourly rate of wage.
- U. The first four (4) hours after eight (8) regular hours Monday through Friday and the first twelve (12) hours on Saturday shall be paid at one and one-half times the hourly rate of wage. (Except on makeup days if work is lost due to inclement weather, then the first eight (8) hours on Saturday may be paid the regular rate.) All hours worked over twelve (12) hours Monday through Saturday, and all hours worked on Sundays and holidays shall be paid at double the hourly rate of wage.

Holiday Codes

5. A. Holidays: New Year's Day, Memorial Day, Independence Day, Labor Day, Thanksgiving Day, Friday after Thanksgiving Day, and Christmas Day (7).
- B. Holidays: New Year's Day, Memorial Day, Independence Day, Labor Day, Thanksgiving Day, Friday after Thanksgiving Day, the day before Christmas, and Christmas Day (8).

Holiday Codes Continued

- 5. C. Holidays: New Year's Day, Presidents' Day, Memorial Day, Independence Day, Labor Day, Thanksgiving Day, the Friday after Thanksgiving Day, And Christmas Day (8).
- D. Holidays: New Year's Day, Memorial Day, Independence Day, Labor Day, Thanksgiving Day, the Friday and Saturday after Thanksgiving Day, And Christmas Day (8).
- H. Holidays: New Year's Day, Memorial Day, Independence Day, Thanksgiving Day, the Day after Thanksgiving Day, And Christmas (6).
- I. Holidays: New Year's Day, Memorial Day, Independence Day, Labor Day, Thanksgiving Day, and Christmas Day (6).
- J. Holidays: New Year's Day, Memorial Day, Independence Day, Thanksgiving Day, Friday after Thanksgiving Day, Christmas Eve Day, And Christmas Day (7).
- K. Holidays: New Year's Day, Presidents' Day, Memorial Day, Independence Day, Labor Day, Thanksgiving Day, Friday After Thanksgiving Day, The Day Before Christmas, And Christmas Day (9).
- L. Holidays: New Year's Day, Martin Luther King Jr. Day, Memorial Day, Independence Day, Labor Day, Thanksgiving Day, Friday after Thanksgiving Day, And Christmas Day (8).
- N. Holidays: New Year's Day, Presidents' Day, Memorial Day, Independence Day, Labor Day, Veterans' Day, Thanksgiving Day, The Friday After Thanksgiving Day, And Christmas Day (9).
- P. Holidays: New Year's Day, Memorial Day, Independence Day, Labor Day, Thanksgiving Day, Friday And Saturday After Thanksgiving Day, The Day Before Christmas, And Christmas Day (9). If A Holiday Falls On Sunday, The Following Monday Shall Be Considered As A Holiday.
- Q. Paid Holidays: New Year's Day, Memorial Day, Independence Day, Labor Day, Thanksgiving Day, and Christmas Day (6).
- R. Paid Holidays: New Year's Day, Memorial Day, Independence Day, Labor Day, Thanksgiving Day, Day After Thanksgiving Day, One-Half Day Before Christmas Day, And Christmas Day. (7 1/2).
- S. Paid Holidays: New Year's Day, Presidents' Day, Memorial Day, Independence Day, Labor Day, Thanksgiving Day, And Christmas Day (7).
- T. Paid Holidays: New Year's Day, Washington's Birthday, Memorial Day, Independence Day, Labor Day, Thanksgiving Day, The Friday After Thanksgiving Day, Christmas Day, And The Day Before Or After Christmas (9).
- Z. Holidays: New Year's Day, Memorial Day, Independence Day, Labor Day, Veterans Day, Thanksgiving Day, the Friday after Thanksgiving Day, And Christmas Day (8).
- 6. A. Paid Holidays: New Year's Day, Presidents' Day, Memorial Day, Independence Day, Labor Day, Thanksgiving Day, the Friday after Thanksgiving Day, And Christmas Day (8).
- E. Paid Holidays: New Year's Day, Day Before Or After New Year's Day, Presidents Day, Memorial Day, Independence Day, Labor Day, Thanksgiving Day, the Friday after Thanksgiving Day, Christmas Day, and a Half-

Benefit Code Key – Effective 3/3/2019 thru 8/30/2019

Day On Christmas Eve Day. (9 1/2).

Holiday Codes Continued

6. G. Paid Holidays: New Year's Day, Martin Luther King Jr. Day, Presidents' Day, Memorial Day, Independence Day, Labor Day, Veterans' Day, Thanksgiving Day, the Friday after Thanksgiving Day, Christmas Day, and Christmas Eve Day (11).
- H. Paid Holidays: New Year's Day, New Year's Eve Day, Memorial Day, Independence Day, Labor Day, Thanksgiving Day, Friday After Thanksgiving Day, Christmas Day, The Day After Christmas, And A Floating Holiday (10).
- I. Paid Holidays: New Year's Day, Memorial Day, Independence Day, Labor Day, Thanksgiving Day, Friday After Thanksgiving Day, And Christmas Day (7).
6. T. Paid Holidays: New Year's Day, Presidents' Day, Memorial Day, Independence Day, Labor Day, Thanksgiving Day, The Friday After Thanksgiving Day, The Last Working Day Before Christmas Day, And Christmas Day (9).
- Z. Holidays: New Year's Day, Memorial Day, Independence Day, Labor Day, Thanksgiving Day, Friday after Thanksgiving Day, And Christmas Day (7). If a holiday falls on Saturday, the preceding Friday shall be considered as the holiday. If a holiday falls on Sunday, the following Monday shall be considered as the holiday.
7. A. Holidays: New Year's Day, Memorial Day, Independence Day, Labor Day, Thanksgiving Day, the Friday and Saturday after Thanksgiving Day, And Christmas Day (8). Any Holiday Which Falls On A Sunday Shall Be Observed As A Holiday On The Following Monday. If any of the listed holidays falls on a Saturday, the preceding Friday shall be a regular work day.
- B. Holidays: New Year's Day, Memorial Day, Independence Day, Labor Day, Thanksgiving Day, the Friday and Saturday after Thanksgiving Day, And Christmas Day (8). Any holiday which falls on a Sunday shall be observed as a holiday on the following Monday. Any holiday which falls on a Saturday shall be observed as a holiday on the preceding Friday.
- C. Holidays: New Year's Day, Martin Luther King Jr. Day, Memorial Day, Independence Day, Labor Day, Thanksgiving Day, the Friday after Thanksgiving Day, And Christmas Day (8). Any holiday which falls on a Sunday shall be observed as a holiday on the following Monday. Any holiday which falls on a Saturday shall be observed as a holiday on the preceding Friday.
- D. Paid Holidays: New Year's Day, Memorial Day, Independence Day, Labor Day, Veteran's Day, Thanksgiving Day, the Friday after Thanksgiving Day, And Christmas Day (8). Unpaid Holidays: President's Day. Any paid holiday which falls on a Sunday shall be observed as a holiday on the following Monday. Any paid holiday which falls on a Saturday shall be observed as a holiday on the preceding Friday.
- E. Holidays: New Year's Day, Memorial Day, Independence Day, Labor Day, Thanksgiving Day, the Friday after Thanksgiving Day, And Christmas Day (7). Any holiday which falls on a Sunday shall be observed as a holiday on the following Monday. Any holiday which falls on a Saturday shall be observed as a holiday on the preceding Friday.
- F. Holidays: New Year's Day, Memorial Day, Independence Day, Labor Day, Thanksgiving Day, the Friday after Thanksgiving Day, the last working day before Christmas day and Christmas day (8). Any holiday which falls on a Sunday shall be observed as a holiday on the following Monday. Any holiday which falls on a Saturday shall be observed as a holiday on the preceding Friday.
- G. Holidays: New Year's Day, Memorial Day, Independence Day, Labor Day, Thanksgiving Day, and Christmas Day (6). Any holiday which falls on a Sunday shall be observed as a holiday on the following Monday.

Holiday Codes Continued

7. H. Holidays: New Year's Day, Martin Luther King Jr. Day, Independence Day, Memorial Day, Labor Day, Thanksgiving Day, the Friday after Thanksgiving Day, the Last Working Day before Christmas Day and Christmas Day (9). Any holiday which falls on a Sunday shall be observed as a holiday on the following Monday. Any holiday which falls on a Saturday shall be observed as a holiday on the preceding Friday.
- I. Holidays: New Year's Day, President's Day, Independence Day, Memorial Day, Labor Day, Thanksgiving Day, The Friday After Thanksgiving Day, The Day Before Christmas Day And Christmas Day (9). Any holiday which falls on a Sunday shall be observed as a holiday on the following Monday. Any holiday which falls on a Saturday shall be observed as a holiday on the preceding Friday.
- J. Holidays: New Year's Day, Independence Day, Memorial Day, Labor Day, Thanksgiving Day and Christmas Day (6). Any holiday which falls on a Sunday shall be observed as a holiday on the following Monday. Any holiday which falls on a Saturday shall be observed as a holiday on the preceding Friday.
- K. Holidays: New Year's Day, Memorial Day, Independence Day, Thanksgiving Day, the Friday and Saturday after Thanksgiving Day, And Christmas Day (8). Any holiday which falls on a Sunday shall be observed as a holiday on the following Monday. Any holiday which falls on a Saturday shall be observed as a holiday on the preceding Friday.
- L. Holidays: New Year's Day, Memorial Day, Labor Day, Independence Day, Thanksgiving Day, the Last Work Day before Christmas Day, And Christmas Day (7). Any holiday which falls on a Sunday shall be observed as a holiday on the following Monday. Any holiday which falls on a Saturday shall be observed as a holiday on the preceding Friday.
- M. Paid Holidays: New Year's Day, The Day after or before New Year's Day, President's Day, Memorial Day, Independence Day, Labor Day, Thanksgiving Day, the Friday after Thanksgiving Day, Christmas Day, And the Day after or before Christmas Day (10). Any holiday which falls on a Sunday shall be observed as a holiday on the following Monday. Any holiday which falls on a Saturday shall be observed as a holiday on the preceding Friday.
- N. Holidays: New Year's Day, Memorial Day, Independence Day, Labor Day, Thanksgiving Day, the Friday after Thanksgiving Day, And Christmas Day (7). Any holiday which falls on a Sunday shall be observed as a holiday on the following Monday. When Christmas falls on a Saturday, the preceding Friday shall be observed as a holiday.
- P. Holidays: New Year's Day, Memorial Day, Independence Day, Labor Day, Thanksgiving Day, Friday after Thanksgiving Day, And Christmas Day (7). Any holiday which falls on a Sunday shall be observed as a holiday on the following Monday.
- Q. Holidays: New Year's Day, Memorial Day, Independence Day, Labor Day, Thanksgiving Day, the Friday after Thanksgiving Day, the Last Working Day before Christmas Day and Christmas Day (8). Any holiday which falls on a Sunday shall be observed as a holiday on the following Monday. If any of the listed holidays falls on a Saturday, the preceding Friday shall be a regular work day.
- R. Paid Holidays: New Year's Day, the day after or before New Year's Day, President's Day, Memorial Day, Independence Day, Labor Day, Thanksgiving Day, the Friday after Thanksgiving Day, Christmas Day, and the day after or before Christmas Day (10). If any of the listed holidays fall on Saturday, the preceding Friday shall be observed as the holiday. If any of the listed holidays falls on a Sunday, the day observed by the Nation shall be considered a holiday and compensated accordingly.
- S. Paid Holidays: New Year's Day, Memorial Day, Independence Day, Labor Day, Thanksgiving Day, Friday after Thanksgiving Day, Christmas Day, the Day after Christmas, and A Floating Holiday (9). If any of the listed holidays falls on a Sunday, the day observed by the Nation shall be considered a holiday and compensated accordingly.

Holiday Codes Continued

7. T. Paid Holidays: New Year's Day, the Day after or before New Year's Day, President's Day, Memorial Day, Independence Day, Labor Day, Thanksgiving Day, the Friday after Thanksgiving Day, Christmas Day, and The Day after or before Christmas Day. (10). If any of the listed holidays falls on a Sunday, the day observed by the Nation shall be considered a holiday and compensated accordingly. Any holiday which falls on a Saturday shall be observed as a holiday on the preceding Friday.
- V. Holidays: New Year's Day, President's Birthday, Memorial Day, Independence Day, Labor Day, Thanksgiving Day, the Friday after Thanksgiving Day, Christmas Day, the day before or after Christmas, and the day before or after New Year's Day. If any of the above listed holidays falls on a Sunday, the day observed by the Nation shall be considered a holiday and compensated accordingly.
- W. Holidays: New Year's Day, Day After New Year's, Memorial Day, Independence Day, Labor Day, Thanksgiving Day, the Friday after Thanksgiving Day, Christmas Eve Day, Christmas Day, the day after Christmas, the day before New Year's Day, and a Floating Holiday.
- X. Holidays: New Year's Day, Day before or after New Year's Day, Presidents' Day, Memorial Day, Independence Day, Labor Day, Thanksgiving Day, the Friday after Thanksgiving Day, Christmas Day, and the day before or after Christmas day. If a holiday falls on a Saturday or on a Friday that is the normal day off, then the holiday will be taken on the last normal workday. If the holiday falls on a Monday that is the normal day off or on a Sunday, then the holiday will be taken on the next normal workday.
- Y. Holidays: New Year's Day, Presidents' Day, Memorial Day, Independence Day, Labor Day, Thanksgiving Day, the Friday after Thanksgiving Day, and Christmas Day. (8) If the holiday falls on a Sunday, then the day observed by the federal government shall be considered a holiday and compensated accordingly.
- Z. Holidays: New Year's Day, President's Day, Independence Day, Memorial Day, Labor Day, Thanksgiving Day, The Friday After Thanksgiving Day, And Christmas Day (8). Any holiday which falls on a Sunday shall be observed as a holiday on the following Monday. Any holiday which falls on a Saturday shall be observed as a holiday on the preceding Friday.
15. A. Holidays: New Year's Day, Memorial Day, Independence Day, Labor Day, Thanksgiving Day, the Friday after Thanksgiving Day, the day before Christmas Day and Christmas Day. (8) Any holiday which falls on a Sunday shall be observed as a holiday on the following Monday.
- B. Holidays: New Year's Day, Martin Luther King Jr. Day, President's Day, Memorial Day, Independence Day, Labor Day, Veteran's Day, Thanksgiving Day, and Christmas Day. (9)
- C. Holidays: New Year's Day, Memorial Day, Independence Day, Labor Day, Thanksgiving Day, the Friday after Thanksgiving Day, the day before Christmas Day and Christmas Day. (8)
- D. Holidays: New Year's Day, Presidents' Day, Memorial Day, Independence Day, Labor Day, Thanksgiving Day, Friday after Thanksgiving Day, Christmas Day, and the day after Christmas.

Benefit Code Key – Effective 3/3/2019 thru 8/30/2019

Note Codes

8. D. Workers working with supplied air on hazmat projects receive an additional \$1.00 per hour.
- L. Workers on hazmat projects receive additional hourly premiums as follows -Level A: \$0.75, Level B: \$0.50, And Level C: \$0.25.
- M. Workers on hazmat projects receive additional hourly premiums as follows: Levels A & B: \$1.00, Levels C & D: \$0.50.
- N. Workers on hazmat projects receive additional hourly premiums as follows -Level A: \$1.00, Level B: \$0.75, Level C: \$0.50, And Level D: \$0.25.
- P. Workers on hazmat projects receive additional hourly premiums as follows -Class A Suit: \$2.00, Class B Suit: \$1.50, Class C Suit: \$1.00, And Class D Suit \$0.50.
- Q. The highest pressure registered on the gauge for an accumulated time of more than fifteen (15) minutes during the shift shall be used in determining the scale paid.
- R. Effective August 31, 2012 – A Traffic Control Supervisor shall be present on the project whenever flagging or spotting or other traffic control labor is being utilized. A Traffic Control Laborer performs the setup, maintenance and removal of all temporary traffic control devices and construction signs necessary to control vehicular, bicycle, and pedestrian traffic during construction operations. Flaggers and Spotters shall be posted where shown on approved Traffic Control Plans or where directed by the Engineer. All flaggers and spotters shall possess a current flagging card issued by the State of Washington, Oregon, Montana, or Idaho. These classifications are only effective on or after August 31, 2012.
- S. Effective August 31, 2012 – A Traffic Control Supervisor shall be present on the project whenever flagging or spotting or other traffic control labor is being utilized. Flaggers and Spotters shall be posted where shown on approved Traffic Control Plans or where directed by the Engineer. All flaggers and spotters shall possess a current flagging card issued by the State of Washington, Oregon, Montana, or Idaho. This classification is only effective on or after August 31, 2012.
- T. Effective August 31, 2012 – A Traffic Control Laborer performs the setup, maintenance and removal of all temporary traffic control devices and construction signs necessary to control vehicular, bicycle, and pedestrian traffic during construction operations. Flaggers and Spotters shall be posted where shown on approved Traffic Control Plans or where directed by the Engineer. All flaggers and spotters shall possess a current flagging card issued by the State of Washington, Oregon, Montana, or Idaho. This classification is only effective on or after August 31, 2012.
- U. Workers on hazmat projects receive additional hourly premiums as follows – Class A Suit: \$2.00, Class B Suit: \$1.50, And Class C Suit: \$1.00. Workers performing underground work receive an additional \$0.40 per hour for any and all work performed underground, including operating, servicing and repairing of equipment. The premium for underground work shall be paid for the entire shift worked. Workers who work suspended by a rope or cable receive an additional \$0.50 per hour. The premium for work suspended shall be paid for the entire shift worked. Workers who do “pioneer” work (break open a cut, build road, etc.) more than one hundred fifty (150) feet above grade elevation receive an additional \$0.50 per hour.

Note Codes Continued

8. V. In addition to the hourly wage and fringe benefits, the following depth and enclosure premiums shall be paid. The premiums are to be calculated for the maximum depth and distance into an enclosure that a diver reaches in a day. The premiums are to be paid one time for the day and are not used in calculating overtime pay.

Depth premiums apply to depths of fifty feet or more. Over 50' to 100' - \$2.00 per foot for each foot over 50 feet. Over 101' to 150' - \$3.00 per foot for each foot over 101 feet. Over 151' to 220' - \$4.00 per foot for each foot over 220 feet. Over 221' - \$5.00 per foot for each foot over 221 feet.

Enclosure premiums apply when divers enter enclosures (such as pipes or tunnels) where there is no vertical ascent and is measured by the distance travelled from the entrance. 25' to 300' - \$1.00 per foot from entrance. 300' to 600' - \$1.50 per foot beginning at 300'. Over 600' - \$2.00 per foot beginning at 600'.

- W. Meter Installers work on single phase 120/240V self-contained residential meters. The Lineman/Groundmen rates would apply to meters not fitting this description.

- X. Workers on hazmat projects receive additional hourly premiums as follows - Class A Suit: \$2.00, Class B Suit: \$1.50, Class C Suit: \$1.00, and Class D Suit: \$0.50. Special Shift Premium: Basic hourly rate plus \$2.00 per hour.

When due to conditions beyond the control of the Employer or when an owner (not acting as the contractor), a government agency or the contract specifications requires that work can only be performed outside the normal 5 am to 6pm shift, then the special shift premium will be applied to the basic hourly rate. When an employee works on a special shift, they shall be paid a special shift premium for each hour worked unless they are in OT or Double-time status. (For example, the special shift premium does not waive the overtime requirements for work performed on Saturday or Sunday.)

"General Decision Number: WA20190001 07/05/2019

Superseded General Decision Number: WA20180001

State: Washington

Construction Type: Highway

Counties: Washington Statewide.

HIGHWAY (Excludes D.O.E. Hanford Site in Benton and Franklin Counties)

Note: Under Executive Order (EO) 13658, an hourly minimum wage of \$10.60 for calendar year 2019 applies to all contracts subject to the Davis-Bacon Act for which the contract is awarded (and any solicitation was issued) on or after January 1, 2015. If this contract is covered by the EO, the contractor must pay all workers in any classification listed on this wage determination at least \$10.60 per hour (or the applicable wage rate listed on this wage determination, if it is higher) for all hours spent performing on the contract in calendar year 2019. If this contract is covered by the EO and a classification considered necessary for performance of work on the contract does not appear on this wage determination, the contractor must pay workers in that classification at least the wage rate determined through the conformance process set forth in 29 CFR 5.5(a)(1)(ii) (or the EO minimum wage rate, if it is higher than the conformed wage rate). The EO minimum wage rate will be adjusted annually. Please note that this EO applies to the above-mentioned types of contracts entered into by the federal government that are subject to the Davis-Bacon Act itself, but it does not apply to contracts subject only to the Davis-Bacon Related Acts, including those set forth at 29 CFR 5.1(a)(2)-(60). Additional information on contractor requirements and worker protections under the EO is available at www.dol.gov/whd/govcontracts.

| Modification Number | Publication Date |
|---------------------|-------------------|
| 0 | 01/04/2019 |
| 1 | 01/18/2019 |
| 2 | 02/15/2019 |
| 3 | 05/03/2019 |
| 4 | 05/24/2019 |
| 5 | 06/14/2019 |
| 6 | 06/28/2019 |
| 7 | 07/05/2019 |

CARP0001-008 06/01/2018

ADAMS, ASOTIN, BENTON, CHELAN, COLUMBIA, DOUGLAS, FERRY, FRANKLIN, GARFIELD, GRANT, KITTITAS, LINCOLN, OKANOGAN, PEND OREILLE, SPOKANE, STEVENS, WALLA WALLA, WHITMAN, and YAKIMA Counties

| | Rates | Fringes |
|--------------|----------|---------|
| CARPENTER | | |
| GROUP 1..... | \$ 33.40 | 16.40 |
| GROUP 2..... | \$ 45.42 | 18.83 |
| GROUP 3..... | \$ 34.52 | 16.40 |
| GROUP 4..... | \$ 34.52 | 16.40 |
| GROUP 5..... | \$ 77.52 | 16.40 |
| GROUP 6..... | \$ 37.76 | 16.40 |
| GROUP 7..... | \$ 38.76 | 16.40 |
| GROUP 8..... | \$ 35.52 | 16.40 |
| GROUP 9..... | \$ 41.76 | 16.40 |

CARPENTER & DIVER CLASSIFICATIONS:

GROUP 1: Carpenter
 GROUP 2: Millwright, Machine Erector
 GROUP 3: Piledriver - includes driving, pulling, cutting, placing collars, setting, welding, or creosote treated material, on all piling
 GROUP 4: Bridge, Dock, and Wharf carpenters
 GROUP 5: Diver Wet
 GROUP 6: Diver Tender, Manifold Operator, ROV Operator
 GROUP 7: Diver Standby
 GROUP 8: Assistant Diver Tender, ROV Tender/Technician
 GROUP 9: Manifold Operator-Mixed Gas

ZONE PAY:

| | | |
|--------|----------------|-----------------|
| ZONE 1 | 0-60 MILES | FREE |
| ZONE 2 | 61-100 | \$4.00/PER HOUR |
| ZONE 3 | OVER 100 MILES | \$6.00/PER HOUR |

DISPATCH POINTS:

CARPENTERS/MILLWRIGHTS: PASCO (515 N Neel Street) or Main Post Office of established residence of employee (Whichever is closest to the worksite).

CARPENTERS/PILEDRIVER: SPOKANE (127 E. AUGUSTA AVE.) or Main Post Office of established residence of employee (Whichever is closest to the worksite).

CARPENTERS: WENATCHEE (27 N. CHELAN) or Main Post Office of established residence of employee (Whichever is closest to the worksite).

CARPENTERS: COEUR D' ALENE (1839 N. GOVERNMENT WAY) or Main Post Office of established residence of employee (Whichever is closest to the worksite).

CARPENTERS: MOSCOW (306 N. JACKSON) or Main Post Office of established residence of employee (Whichever is closest to the worksite).

DEPTH PAY FOR DIVERS BELOW WATER SURFACE:

50-100 feet \$2.00 per foot
 101-150 feet \$3.00 per foot
 151-220 feet \$4.00 per foot
 221 feet and deeper \$5.00 per foot

PREMIUM PAY FOR DIVING IN ENCLOSURES WITH NO VERTICAL ASCENT:

0-25 feet Free
 26-300 feet \$1.00 per Foot

SATURATION DIVING:

The standby rate applies until saturation starts. The saturation diving rate applies when divers are under pressure continuously until work task and decompression are complete. the diver rate shall be paid for all saturation hours.

WORK IN COMBINATION OF CLASSIFICATIONS:

Employees working in any combination of classifications within the diving crew (except dive supervisor) in a shift are paid in the classification with the highest rate for that shift.

HAZMAT PROJECTS:

Anyone working on a HAZMAT job (task), where HAZMAT certification is required, shall be compensated at a premium, in addition to the classification working in as follows:

LEVEL D + \$.25 per hour - This is the lowest level of protection. No respirator is used and skin protection is minimal.

LEVEL C + \$.50 per hour - This level uses an air purifying respirator or additional protective clothing.

LEVEL B + \$.75 per hour - Uses same respirator protection as Level A. Supplied air line is provided in conjunction with a chemical "splash suit".

LEVEL A +\$1.00 per hour - This level utilizes a fully encapsulated suit with a self-contained breathing apparatus or a supplied air line.

 CARP0003-006 06/01/2018

SOUTHWEST WASHINGTON: CLARK, COWLITZ, KLICKITAT,
 LEWIS(Piledriver only), PACIFIC (South of a straight line made
 by extending the north boundary line of Wahkiakum County west
 to Willapa Bay to the Pacific Ocean), SKAMANIA, and WAHKIAKUM
 Counties.

| | Rates | Fringes |
|---------------------|----------|---------|
| Carpenters: | | |
| CARPENTERS..... | \$ 37.64 | 16.83 |
| DIVERS TENDERS..... | \$ 43.73 | 16.83 |
| DIVERS..... | \$ 87.73 | 16.83 |
| DRYWALL..... | \$ 37.64 | 16.83 |
| MILLWRIGHTS..... | \$ 38.17 | 16.83 |
| PILEDRIVERS..... | \$ 38.71 | 16.83 |

DEPTH PAY:
 50 TO 100 FEET \$1.00 PER FOOT OVER 50 FEET
 101 TO 150 FEET \$1.50 PER FOOT OVER 101 FEET
 151 TO 200 FEET \$2.00 PER FOOT OVER 151 FEET

Zone Differential (Add up Zone 1 rates):
 Zone 2 - \$0.85
 Zone 3 - 1.25
 Zone 4 - 1.70
 Zone 5 - 2.00
 Zone 6 - 3.00

BASEPOINTS: ASTORIA, LONGVIEW, PORTLAND, THE DALLES, AND
 VANCOUVER, (NOTE: All dispatches for Washington State
 Counties: Cowlitz, Wahkiakum and Pacific shall be from
 Longview Local #1707 and mileage shall be computed from
 that point.)

ZONE 1: Projects located within 30 miles of the respective
 city hall of the above mentioned cities
 ZONE 2: Projects located more than 30 miles and less than 40
 miles of the respective city of the above mentioned cities
 ZONE 3: Projects located more than 40 miles and less than 50
 miles of the respective city of the above mentioned cities
 ZONE 4: Projects located more than 50 miles and less than 60
 miles of the respective city of the above mentioned cities.
 ZONE 5: Projects located more than 60 miles and less than 70
 miles of the respective city of the above mentioned cities
 ZONE 6: Projects located more than 70 miles of the respected
 city of the above mentioned cities

CARP0770-003 06/01/2018

| | Rates | Fringes |
|---|-------|---------|
| CARPENTER | | |
| CENTRAL WASHINGTON: | | |
| CHELAN, DOUGLAS (WEST OF THE 120TH MERIDIAN), KITTITAS, OKANOGAN (WEST OF THE 120TH MERIDIAN) AND YAKIMA COUNTIES | | |

| | | |
|--|----------|-------|
| CARPENTERS ON CREOSOTE | | |
| MATERIAL..... | \$ 29.15 | 13.93 |
| CARPENTERS..... | \$ 29.05 | 13.93 |
| DIVERS TENDER..... | \$ 48.59 | 16.12 |
| DIVERS..... | \$ 97.43 | 16.12 |
| MILLWRIGHT AND MACHINE | | |
| ERECTORS..... | \$ 45.42 | 16.12 |
| PILED RIVER, DRIVING, PULLING, CUTTING, PLACING COLLARS, SETTING, WELDING OR CREOSOTE TREATED | | |
| MATERIAL, ALL PILING..... | \$ 44.17 | 13.93 |

(HOURLY ZONE PAY: WESTERN AND CENTRAL WASHINGTON - ALL CLASSIFICATIONS EXCEPT MILLWRIGHTS AND PILED RIVERS)

Hourly Zone Pay shall be paid on jobs located outside of the free zone computed from the city center of the following listed cities:

| | | |
|------------------|--------------|--------------|
| Seattle | Olympia | Bellingham |
| Auburn | Bremerton | Anacortes |
| Renton | Shelton | Yakima |
| Aberdeen-Hoquiam | Tacoma | Wenatchee |
| Ellensburg | Everett | Port Angeles |
| Centralia | Mount Vernon | Sunnyside |
| Chelan | Pt. Townsend | |

Zone Pay:

| | |
|----------------------|-------------|
| 0 -25 radius miles | Free |
| 26-35 radius miles | \$1.00/hour |
| 36-45 radius miles | \$1.15/hour |
| 46-55 radius miles | \$1.35/hour |
| Over 55 radius miles | \$1.55/hour |

(HOURLY ZONE PAY: WESTERN AND CENTRAL WASHINGTON - MILLWRIGHT AND PILED RIVER ONLY)

Hourly Zone Pay shall be computed from Seattle Union Hall, Tacoma City center, and Everett City center

Zone Pay:

| | |
|----------------------|-------------|
| 0 -25 radius miles | Free |
| 26-45 radius miles | \$.70/hour |
| Over 45 radius miles | \$1.50/hour |

CARP0770-006 06/01/2018

| | Rates | Fringes |
|--|----------|---------|
| CARPENTER | | |
| WESTERN WASHINGTON: CLALLAM, GRAYS HARBOR, ISLAND, JEFFERSON, KING, KITSAP, LEWIS (excludes piledrivers only), MASON, PACIFIC (North of a straight line made by extending the north boundary line of Wahkiakum County west to the Pacific Ocean), PIERCE, SAN JUAN, SKAGIT, SNOHOMISH, THURSTON AND WHATCOM COUNTIES | | |
| BRIDGE CARPENTERS..... | \$ 43.92 | 16.12 |
| CARPENTERS ON CREOSOTE | | |
| MATERIAL..... | \$ 44.02 | 16.12 |
| CARPENTERS..... | \$ 43.92 | 16.12 |
| DIVERS TENDER..... | \$ 48.59 | 16.12 |
| DIVERS..... | \$ 97.48 | 16.12 |
| MILLWRIGHT AND MACHINE | | |
| ERECTORS..... | \$ 45.42 | 16.12 |
| PILEDRIVER, DRIVING, PULLING, CUTTING, PLACING COLLARS, SETTING, WELDING OR CRESOTE TREATED | | |
| MATERIAL, ALL PILING..... | \$ 44.17 | 16.12 |

(HOURLY ZONE PAY: WESTERN AND CENTRAL WASHINGTON - ALL CLASSIFICATIONS EXCEPT MILLWRIGHTS AND PILEDRIVERS

Hourly Zone Pay shall be paid on jobs located outside of the free zone computed from the city center of the following listed cities:

| | | |
|------------------|--------------|--------------|
| Seattle | Olympia | Bellingham |
| Auburn | Bremerton | Anacortes |
| Renton | Shelton | Yakima |
| Aberdeen-Hoquiam | Tacoma | Wenatchee |
| Ellensburg | Everett | Port Angeles |
| Centralia | Mount Vernon | Sunnyside |
| Chelan | Pt. Townsend | |

Zone Pay:

| | |
|----------------------|-------------|
| 0 -25 radius miles | Free |
| 26-35 radius miles | \$1.00/hour |
| 36-45 radius miles | \$1.15/hour |
| 46-55 radius miles | \$1.35/hour |
| Over 55 radius miles | \$1.55/hour |

(HOURLY ZONE PAY: WESTERN AND CENTRAL WASHINGTON - MILLWRIGHT AND PILEDRIVER ONLY)

Hourly Zone Pay shall be computed from Seattle Union Hall, Tacoma City center, and Everett City center

Zone Pay:

| | |
|----------------------|-------------|
| 0 -25 radius miles | Free |
| 26-45 radius miles | \$.70/hour |
| Over 45 radius miles | \$1.50/hour |

ELEC0046-001 02/04/2019

CALLAM, JEFFERSON, KING AND KITSAP COUNTIES

| | Rates | Fringes |
|--------------------|----------|---------|
| CABLE SPLICER..... | \$ 58.84 | 22.48 |
| ELECTRICIAN..... | \$ 53.49 | 22.31 |

* ELEC0048-003 01/01/2019

CLARK, KLINKITAT AND SKAMANIA COUNTIES

| | Rates | Fringes |
|--------------------|----------|---------|
| CABLE SPLICER..... | \$ 44.22 | 21.50 |
| ELECTRICIAN..... | \$ 44.85 | 23.57 |

HOURLY ZONE PAY:

Hourly Zone Pay shall be paid on jobs located outside of the free zone computed from the city center of the following listed cities:

Portland, The Dalles, Hood River, Tillamook, Seaside and Astoria

Zone Pay:

Zone 1: 31-50 miles \$1.50/hour
 Zone 2: 51-70 miles \$3.50/hour
 Zone 3: 71-90 miles \$5.50/hour
 Zone 4: Beyond 90 miles \$9.00/hour

*These are not miles driven. Zones are based on Delorme Street Atlas USA 2006 plus.

ELEC0048-029 01/01/2019

COWLITZ AND WAHKIAKUM COUNTY

| | Rates | Fringes |
|--------------------|----------|---------|
| CABLE SPLICER..... | \$ 44.22 | 21.50 |
| ELECTRICIAN..... | \$ 44.85 | 23.57 |

ELEC0073-001 01/01/2019

ADAMS, FERRY, LINCOLN, PEND OREILLE, SPOKANE, STEVENS, WHITMAN COUNTIES

| | Rates | Fringes |
|--------------------|----------|---------|
| CABLE SPLICER..... | \$ 34.10 | 16.68 |
| ELECTRICIAN..... | \$ 34.30 | 18.88 |

 ELEC0076-002 08/31/2018

GRAYS HARBOR, LEWIS, MASON, PACIFIC, PIERCE, AND THURSTON
 COUNTIES

| | Rates | Fringes |
|--------------------|----------|---------|
| CABLE SPLICER..... | \$ 48.06 | 23.23 |
| ELECTRICIAN..... | \$ 43.69 | 23.10 |

ELEC0112-005 06/01/2018

ASOTIN, BENTON, COLUMBIA, FRANKLIN, GARFIELD, KITTITAS, WALLA
 WALLA, YAKIMA COUNTIES

| | Rates | Fringes |
|--------------------|----------|---------|
| CABLE SPLICER..... | \$ 45.68 | 20.60 |
| ELECTRICIAN..... | \$ 43.50 | 20.54 |

ELEC0191-003 06/01/2018

ISLAND, SAN JUAN, SNOHOMISH, SKAGIT AND WHATCOM COUNTIES

| | Rates | Fringes |
|--------------------|----------|---------|
| CABLE SPLICER..... | \$ 44.23 | 17.73 |
| ELECTRICIAN..... | \$ 44.95 | 21.42 |

ELEC0191-004 06/01/2018

CHELAN, DOUGLAS, GRANT AND OKANOGAN COUNTIES

| | Rates | Fringes |
|--------------------|----------|---------|
| CABLE SPLICER..... | \$ 40.82 | 17.63 |
| ELECTRICIAN..... | \$ 42.45 | 21.34 |

ENGI0302-003 06/01/2018

CHELAN (WEST OF THE 120TH MERIDIAN), CLALLAM, DOUGLAS (WEST OF THE 120TH MERIDIAN), GRAYS HARBOR, ISLAND, JEFFERSON, KING, KITSAP, KITTITAS, MASON, OKANOGAN (WEST OF THE 120TH MERIDIAN), SAN JUNA, SKAGIT, SNOHOMISH, WHATCOM AND YAKIMA (WEST OF THE 120TH MERIDIAN) COUNTIES

Zone 1 (0-25 radius miles):

| | Rates | Fringes |
|--------------------------|----------|---------|
| POWER EQUIPMENT OPERATOR | | |
| Group 1A..... | \$ 44.44 | 19.97 |
| Group 1AA..... | \$ 45.09 | 19.97 |
| Group 1AAA..... | \$ 45.73 | 19.97 |
| Group 1..... | \$ 43.79 | 19.97 |
| Group 2..... | \$ 43.23 | 19.97 |
| Group 3..... | \$ 42.74 | 19.97 |
| Group 4..... | \$ 40.01 | 19.97 |

Zone Differential (Add to Zone 1 rates):

Zone 2 (26-45 radius miles) - \$1.00

Zone 3 (Over 45 radius miles) - \$1.30

BASEPOINTS: Aberdeen, Bellingham, Bremerton, Everett, Kent, Mount Vernon, Port Angeles, Port Townsend, Seattle, Shelton, Wenatchee, Yakima

POWER EQUIPMENT OPERATORS CLASSIFICATIONS

GROUP 1AAA - Cranes-over 300 tons, or 300 ft of boom (including jib with attachments)

GROUP 1AA - Cranes 200 to 300 tons, or 250 ft of boom (including jib with attachments); Tower crane over 175 ft in height, base to boom

GROUP 1A - Cranes, 100 tons thru 199 tons, or 150 ft of boom (including jib with attachments); Crane-overhead, bridge type, 100 tons and over; Tower crane up to 175 ft in height base to boom; Loaders-overhead, 8 yards and over; Shovels, excavator, backhoes-6 yards and over with attachments

GROUP 1 - Cableway; Cranes 45 tons thru 99 tons, under 150 ft of boom (including jib with attachments); Crane-overhead, bridge type, 45 tons thru 99 tons; Derricks on building work; Excavator, shovel, backhoes over 3 yards and under 6 yards; Hard tail end dump articulating off-road equipment 45 yards and over; Loader- overhead 6 yards to, but not including 8 yards; Mucking machine, mole, tunnel, drill and/or shield; Quad 9, HD 41, D-10; Remote control operator on rubber tired earth moving equipment; Rollagon; Scrapers-self propelled 45 yards and over; Slipform pavers; Transporters, all truck or track type

GROUP 2 - Barrier machine (zipper); Batch Plant Operaor-
Concrete; Bump Cutter; Cranes, 20 tons thru 44 tons with
attachments; Crane-overhead, bridge type-20 tons through 44
tons; Chipper; Concrete Pump-truck mount with boom
attachment; Crusher; Deck Engineer/Deck Winches (power);
Drilling machine; Excavator, shovel, backhoe-3yards and
under; Finishing Machine, Bidwell, Gamaco and similar
equipment; Guardrail punch; Horizontal/directional drill
operator; Loaders-overhead under 6 yards; Loaders-plant
feed; Locomotives-all; Mechanics-all; Mixers-asphalt plant;
Motor patrol graders-finishing; Piledriver (other than
crane mount); Roto-mill,roto-grinder; Screedman, spreader,
topside operator-Blaw Knox, Cedar Rapids, Jaeger,
Caterpillar, Barbar Green; Scraper-self propelled, hard
tail end dump, articulating off-road equipment-under 45
yards; Subgrade trimmer; Tractors, backhoes-over 75 hp;
Transfer material service machine-shuttle buggy, blaw
knox-roadtec; Truck crane oiler/driver-100 tons and over;
Truck Mount portable conveyor; Yo Yo Pay dozer

GROUP 3 - Conveyors; Cranes-thru 19 tons with attachments;
A-frame crane over 10 tons; Drill oilers-auger type, truck
or crane mount; Dozers-D-9 and under; Forklift-3000 lbs.
and over with attachments; Horizontal/directional drill
locator; Outside hoists-(elevators and manlifts), air
tuggers, strato tower bucket elevators; Hydralifts/boom
trucks over 10 tons; Loader-elevating type, belt; Motor
patrol grader-nonfinishing; Plant oiler- asphalt, crusher;
Pumps-concrete; Roller, plant mix or multi-lift materials;
Saws-concrete; Scrpers-concrete and carry-all; Service
engineer-equipment; Trenching machines; Truck Crane
Oiler/Driver under 100 tons; Tractors, backhoe 75 hp and
under

GROUP 4 - Assistant Engineer; Bobcat; Brooms; Compressor;
Concrete finish mahine-laser screed; Cranes-A frame-10 tons
and under; Elevator and Manlift-permanent or shaft type;
Gradechecker, Stakehop; Forklifts under 3000 lbs. with
attachments; Hydralifts/boom trucks, 10 tons and under; Oil
distributors, blower distribution and mulch seeding
operator; Pavement breaker; Posthole digger, mechanical;
Power plant; Pumps, water; Rigger and Bellman; Roller-other
than plant mix; Wheel Tractors, farmall type;
Shotcrete/gunite equipment operator

HANDLING OF HAZARDOUS WASTE MATERIALS:

Personnel in all craft classifications subject to working inside a federally designated hazardous perimeter shall be eligible for compensation in accordance with the following group schedule relative to the level of hazardous waste as outlined in the specific hazardous waste project site safety plan.

H-1 Base wage rate when on a hazardous waste site when not outfitted with protective clothing

H-2 Class "C" Suit - Base wage rate plus \$.25 per hour.

H-3 Class "B" Suit - Base wage rate plus \$.50 per hour.

H-4 Class "A" Suit - Base wage rate plus \$.75 per hour.

ENGI0370-002 06/01/2018

ADAMS, ASOTIN, BENTON, CHELAN (EAST OF THE 120TH MERIDIAN), COLUMBIA, DOUGLAS (EAST OF THE 120TH MERIDIAN), FERRY, FRANKLIN, GARFIELD, GRANT, LINCOLN, OKANOGAN (EAST OF THE 120TH MERIDIAN), PEND OREILLE, SPOKANE, STEVENS, WALLA WALLA, WHITMAN AND YAKIMA (EAST OF THE 120TH MERIDIAN) COUNTIES

ZONE 1:

| | Rates | Fringes |
|--------------------------|----------|---------|
| POWER EQUIPMENT OPERATOR | | |
| GROUP 1..... | \$ 27.51 | 15.95 |
| GROUP 2..... | \$ 27.83 | 15.95 |
| GROUP 3..... | \$ 28.44 | 15.95 |
| GROUP 4..... | \$ 28.60 | 15.95 |
| GROUP 5..... | \$ 28.76 | 15.95 |
| GROUP 6..... | \$ 29.04 | 15.95 |
| GROUP 7..... | \$ 29.31 | 15.95 |
| GROUP 8..... | \$ 30.41 | 15.95 |

ZONE DIFFERENTIAL (Add to Zone 1 rate): Zone 2 - \$2.00

Zone 1: Within 45 mile radius of Spokane, Pasco, Washington; Lewiston, Idaho

Zone 2: Outside 45 mile radius of Spokane, Pasco, Washington; Lewiston, Idaho

POWER EQUIPMENT OPERATORS CLASSIFICATIONS

GROUP 1: Bit Grinders; Bolt Threading Machine; Compressors (under 2000 CFM, gas, diesel, or electric power); Deck Hand; Fireman & Heater Tender; Hydro-seeder, Mulcher, Nozzleman; Oiler Driver, & Cable Tender, Mucking Machine; Pumpman; Rollers, all types on subgrade, including seal and chip coatings (farm type, Case, John Deere & similar, or Compacting Vibrator), except when pulled by Dozer with operable blade; Welding Machine; Crane Oiler-Driver (CLD required) & Cable Tender, Mucking Machine

GROUP 2: A-frame Truck (single drum); Assistant Refrigeration Plant (under 1000 ton); Assistant Plant Operator, Fireman or Pugmixer (asphalt); Bagley or Stationary Scraper; Belt Finishing Machine; Blower Operator (cement); Cement Hog; Compressor (2000 CFM or over, 2 or more, gas diesel or electric power); Concrete Saw (multiple cut); Distributor Leverman; Ditch Witch or similar; Elevator Hoisting Materials; Dope Pots (power agitated); Fork Lift or Lumber Stacker, hydra-lift & similar; Gin Trucks (pipeline); Hoist, single drum; Loaders (bucket elevators and conveyors); Longitudinal Float; Mixer (portable-concrete); Pavement Breaker, Hydra-Hammer & similar; Power Broom; Railroad Ballast Regulation Operator (self-propelled); Railroad Power Tamper Operator (self-propelled); Railroad Tamper Jack Operator (self-propelled); Spray Curing Machine (concrete); Spreader Box (self-propelled); Straddle Buggy (Ross & similar on construction job only); Tractor (Farm type R/T with attachment, except Backhoe); Tugger Operator

GROUP 3: A-frame Truck (2 or more drums); Assistant Refrigeration Plant & Chiller Operator (over 1000 ton); Backfillers (Cleveland & similar); Batch Plant & Wet Mix Operator, single unit (concrete); Belt-Crete Conveyors with power pack or similar; Belt Loader (Kocal or similar); Bending Machine; Bob Cat (Skid Steer); Boring Machine (earth); Boring Machine (rock under 8 inch bit) (Quarry Master, Joy or similar); Bump Cutter (Wayne, Saginaw or similar); Canal Lining Machine (concrete); Chipper (without crane); Cleaning & Doping Machine (pipeline); Deck Engineer; Elevating Belt-type Loader (Euclid, Barber Green & similar); Elevating Grader-type Loader (Dumor, Adams or similar); Generator Plant Engineers (diesel or electric); Gunnite Combination Mixer & Compressor; Locomotive Engineer; Mixermobile; Mucking Machine; Posthole Auger or Punch; Pump (grout or jet); Soil Stabilizer (P & H or similar); Spreader Machine; Dozer/Tractor (up to D-6 or equivalent) and Traxcavator; Traverse Finish Machine; Turnhead Operator

GROUP 4: Concrete Pumps (squeeze-crete, flow-crete, pump-crete, Whitman & similar); Curb Extruder (asphalt or concrete); Drills (churn, core, calyx or diamond); Equipment Serviceman; Greaser & Oiler; Hoist (2 or more drums or Tower Hoist); Loaders (overhead & front-end, under 4 yds. R/T); Refrigeration Plant Engineer (under 1000 ton); Rubber-tired Skidders (R/T with or without attachments); Surface Heater & Plant Machine; Trenching Machines (under 7 ft. depth capacity); Turnhead (with re-screening); Vacuum Drill (reverse circulation drill under 8 inch bit)

GROUP 5: Backhoe (under 45,000 gw); Backhoe & Hoe Ram (under 3/4 yd.); Carrydeck & Boom Truck (under 25 tons); Cranes (25 tons & under), all attachments including clamshell, dragline; Derricks & Stifflegs (under 65 tons); Drilling Equipment(8 inch bit & over) (Robbins, reverse circulation & similar); Hoe Ram; Piledriving Engineers; Paving (dual drum); Railroad Track Liner Operatr (self-propelled); Refrigeration Plant Engineer (1000 tons & over); Signalman (Whirleys, Highline Hammerheads or similar); Grade Checker

GROUP 6: Asphalt Plant Operator; Automatic Subgrader (Ditches & Trimmers)(Autograde, ABC, R.A. Hansen & similar on grade wire); Backhoe (45,000 gw and over to 110,000 gw); Backhoes & Hoe Ram (3/4 yd. to 3 yd.); Batch Plant (over 4 units); Batch & Wet Mix Operator (multiple units, 2 & incl. 4); Blade Operator (motor patrol & attachments); Cable Controller (dispatcher); Compactor (self-propelled with blade); Concrete Pump Boom Truck; Concrete Slip Form Paver; Cranes (over 25 tons, to and including 45 tons), all attachments including clamshell, dragline; Crusher, Grizzle & Screening Plant Operator; Dozer, 834 R/T & similar; Drill Doctor; Loader Operator (front-end & overhead, 4 yds. incl. 8 yds.); Multiple Dozer Units with single blade; Paving Machine (asphalt and concrete); Quad-Track or similar equipment; Rollerwoman (finishing asphalt pavement); Roto Mill (pavement grinder); Scrapers, all, rubber-tired; Screed Operator; Shovel(under 3 yds.); Trenching Machines (7 ft. depth & over); Tug Boat Operator Vactor guzzler, super sucker; Lime Batch Tank Operator (REcycle Train); Lime Brain Operator (Recycle Train); Mobile Crusher Operator (Recycle Train)

GROUP 7: Backhoe (over 110,000 gw); Backhoes & Hoe Ram (3 yds & over); Blade (finish & bluetop) Automatic, CMI, ABC, Finish Athey & Huber & similar when used as automatic; Cableway Operators; Concrete Cleaning/Decontamination machine operator; Cranes (over 45 tons to but not including 85 tons), all attachments including clamshell and dragline; Derricks & Stiffleys (65 tons & over); Elevating Belt (Holland type); Heavy equipment robotics operator; Loader (360 degrees revolving Koehring Scooper or similar); Loaders (overhead & front-end, over 8 yds. to 10 yds.); Rubber-tired Scrapers (multiple engine with three or more scrapers); Shovels (3 yds. & over); Whirleys & Hammerheads, ALL; H.D. Mechanic; H.D. Welder; Hydraulic Platform Trailers (Goldhofer, Shaurerly and Similar); Ultra High Pressure Waterjet Cutting Tool System Operator (30,000 psi); Vacuum Blasting Machine Operator

GROUP 8: Cranes (85 tons and over, and all climbing, overhead, rail and tower), all attachments including clamshell, dragline; Loaders (overhead and front-end, 10 yards and over); Helicopter Pilot

BOOM PAY: (All Cranes, Including Tower)
 180 ft to 250 ft \$.50 over scale
 Over 250 ft \$.80 over scale

NOTE:

In computing the length of the boom on Tower Cranes, they shall be measured from the base of the Tower to the point of the boom.

HAZMAT:

Anyone working on HAZMAT jobs, working with supplied air shall receive \$1.00 an hour above classification.

 ENGI0612-001 09/28/2018

PIERCE County

ON PROJECTS DESCRIBED IN FOOTNOTE A BELOW, THE RATE FOR EACH GROUP SHALL BE 90% OF THE BASE RATE PLUS FULL FRINGE BENEFITS. ON ALL OTHER WORK, THE FOLLOWING RATES APPLY.

Zone 1 (0-25 radius miles):

| | Rates | Fringes |
|--------------------------|----------|---------|
| POWER EQUIPMENT OPERATOR | | |
| GROUP 1A..... | \$ 44.44 | 19.97 |
| GROUP 1AA..... | \$ 45.09 | 19.97 |
| GROUP 1AAA..... | \$ 45.73 | 19.97 |
| GROUP 1..... | \$ 43.79 | 19.97 |
| GROUP 2..... | \$ 43.23 | 19.97 |
| GROUP 3..... | \$ 42.74 | 19.97 |
| GROUP 4..... | \$ 40.01 | 19.97 |

Zone Differential (Add to Zone 1 rates):

Zone 2 (26-45 radius miles) = \$1.00

Zone 3 (Over 45 radius miles) - \$1.30

BASEPOINTS: CENTRALIA, OLYMPIA, TACOMA

POWER EQUIPMENT OPERATORS CLASSIFICATIONS

GROUP 1 AAA - Cranes-over 300 tons or 300 ft of boom
(including jib with attachments)

GROUP 1AA - Cranes- 200 tons to 300 tons, or 250 ft of boom
(including jib with attachments; Tower crane over 175 ft in
height, base to boom)

GROUP 1A - Cranes, 100 tons thru 199 tons, or 150 ft of boom
(including jib with attachments); Crane-overhead, bridge
type, 100 tons and over; Tower crane up to 175 ft in height
base to boom; Loaders-overhead, 8 yards and over; Shovels,
excavator, backhoes-6 yards and over with attachments

GROUP 1 - Cableway; Cranes 45 tons thru 99 tons under 150 ft
of boom (including jib with attachments); Crane-overhead,
bridge type, 45 tons thru 99 tons; Derricks on building
work; Excavator, shovel, backhoes over 3 yards and under 6
yards; Hard tail end dump articulating off-road equipment
45 yards and over; Loader- overhead, 6 yards to, but not
including, 8 yards; Mucking machine, mole, tunnel, drill
and/or shield; Quad 9 HD 41, D-10; Remote control operator
on rubber tired earth moving equipment; Rollagon; Scrapers-
self-propelled 45 yards and over; Slipform pavers;
Transporters, all track or truck type

GROUP 2 - Barrier machine (zipper); Batch Plant Operator-
concrete; Bump Cutter; Cranes, 20 tons thru 44 tons with
attachments; Crane-Overhead, bridge type, 20 tons through
44 tons; Chipper; Concrete pump-truck mount with boom
attachment; Crusher; Deck engineer/deck winches (power);
Drilling machine; Excavator, shovel, backhoe-3 yards and
under; Finishing machine, Bidwell, Gamaco and similar
equipment; Guardrail punch; Loaders, overhead under 6
yards; Loaders-plant feed; Locomotives-all; Mechanics- all;
Mixers, asphalt plant; Motor patrol graders, finishing;
Piledriver (other than crane mount); Roto-mill, roto-
grinder; Screedman, spreader, topside operator-Blaw Knox,
Cedar Rapids, Jaeger, Caterpillar, Barbar Green;
Scraper-self- propelled, hard tail end dump, articulating
off-road equipment- under 45 yards; Subgrader trimmer;
Tractors, backhoe over 75 hp; Transfer material service
machine-shuttle buggy, Blaw Knox- Roadtec; Truck Crane
oiler/driver-100 tons and over; Truck Mount Portable
Conveyor; Yo Yo pay

GROUP 3 - Conveyors; Cranes through 19 tons with attachments; Crane-A-frame over 10 tons; Drill oilers-auger type, truck or crane mount; Dozer-D-9 and under; Forklift-3000 lbs. and over with attachments; Horizontal/directional drill locator; Outside Hoists-(elevators and manlifts), air tuggers, strato tower bucket elevators; Hydralifts/boom trucks over 10 tons; Loaders-elevating type, belt; Motor patrol grader-nonfinishing; Plant oiler- asphalt, crusher; Pump-Concrete; Roller, plant mix or multi-lfit materials; Saws-concrete; Scrapers, concrete and carry all; Service engineers-equipment; Trenching machines; Truck crane oiler/driver under 100 tons; Tractors, backhoe under 75 hp

GROUP 4 - Assistant Engineer; Bobcat; Brooms; Compressor; Concrete Finish Machine-laser screed; Cranes A-frame 10 tons and under; Elevator and manlift (permanent and shaft type); Forklifts-under 3000 lbs. with attachments; Gradechecker, stakehop; Hydralifts/boom trucks, 10 tons and under; Oil distributors, blower distribution and mulch seeding operator; Pavement breaker; Posthole digger-mechanical; Power plant; Pumps-water; Rigger and Bellman; Roller-other than plant mix; Wheel Tractors, farmall type; Shotcrete/gunite equipment operator

FOOTNOTE A- Reduced rates may be paid on the following:

1. Projects involving work on structures such as buildings and bridges whose total value is less than \$1.5 million excluding mechanical, electrical, and utility portions of the contract.
2. Projects of less than \$1 million where no building is involved. Surfacing and paving included, but utilities excluded.
3. Marine projects (docks, wharfs, etc.) less than \$150,000.

HANDLING OF HAZARDOUS WASTE MATERIALS: Personnel in all craft classifications subject to working inside a federally designated hazardous perimeter shall be eligible for compensation in accordance with the following group schedule relative to the level of hazardous waste as outlined in the specific hazardous waste project site safety plan.

H-1 Base wage rate when on a hazardous waste site when not outfitted with protective clothing, Class "D" Suit - Base wage rate plus \$.50 per hour.

H-2 Class "C" Suit - Base wage rate plus \$1.00 per hour.

H-3 Class "B" Suit - Base wage rate plus \$1.50 per hour.

H-4 Class "A" Suit - Base wage rate plus \$2.00 per hour.

ENGI0612-012 09/28/2018

LEWIS, PACIFIC (portion lying north of a parallel line extending west from the northern boundary of Wahkaikum County to the sea) AND THURSTON COUNTIES

ON PROJECTS DESCRIBED IN FOOTNOTE A BELOW, THE RATE FOR EACH GROUP SHALL BE 90% OF THE BASE RATE PLUS FULL FRINGE BENEFITS. ON ALL OTHER WORK, THE FOLLOWING RATES APPLY.

Zone 1 (0-25 radius miles):

| | Rates | Fringes |
|--------------------------|----------|---------|
| POWER EQUIPMENT OPERATOR | | |
| GROUP 1A..... | \$ 44.44 | 19.97 |
| GROUP 1AA..... | \$ 45.09 | 19.97 |
| GROUP 1AAA..... | \$ 45.73 | 19.97 |
| GROUP 1..... | \$ 43.79 | 19.97 |
| GROUP 2..... | \$ 43.23 | 19.97 |
| GROUP 3..... | \$ 42.74 | 19.97 |
| GROUP 4..... | \$ 40.01 | 19.97 |

Zone Differential (Add to Zone 1 rates):

Zone 2 (26-45 radius miles) = \$1.00

Zone 3 (Over 45 radius miles) - \$1.30

BASEPOINTS: CENTRALIA, OLYMPIA, TACOMA

POWER EQUIPMENT OPERATORS CLASSIFICATIONS

GROUP 1 AAA - Cranes-over 300 tons or 300 ft of boom (including jib with attachments)

GROUP 1AA - Cranes- 200 tonsto 300 tons, or 250 ft of boom (including jib with attachments; Tower crane over 175 ft in height, bas to boom

GROUP 1A - Cranes, 100 tons thru 199 tons, or 150 ft of boom (including jib with attachments); Crane-overhead, bridge type, 100 tons and over; Tower crane up to 175 ft in height base to boom; Loaders-overhead, 8 yards and over; Shovels, excavator, backhoes-6 yards and over with attachments

GROUP 1 - Cableway; Cranes 45 tons thru 99 tons under 150 ft of boom (including jib with attachments); Crane-overhead, bridge type, 45 tons thru 99 tons; Derricks on building work; Excavator, shovel, backhoes over 3 yards and under 6 yards; Hard tail end dump articulating off-road equipment 45 yards and over; Loader- overhead, 6 yards to, but not including, 8 yards; Mucking machine, mole, tunnel, drill and/or shield; Quad 9 HD 41, D-10; Remote control operator on rubber tired earth moving equipment; Rollagon; Scrapers-self-propelled 45 yards and over; Slipform pavers; Transporters, all track or truck type

GROUP 2 - Barrier machine (zipper); Batch Plant Operator-concrete; Bump Cutter; Cranes, 20 tons thru 44 tons with attachments; Crane-Overhead, bridge type, 20 tons through 44 tons; Chipper; Concrete pump-truck mount with boom attachment; Crusher; Deck engineer/deck winches (power); Drilling machine; Excavator, shovel, backhoe-3 yards and under; Finishing machine, Bidwell, Gamaco and similar equipment; Guardrail punch; Loaders, overhead under 6 yards; Loaders-plant feed; Locomotives-all; Mechanics- all; Mixers, asphalt plant; Motor patrol graders, finishing; Piledriver (other than crane mount); Roto-mill, roto-grinder; Screedman, spreader, topside operator-Blaw Knox, Cedar Rapids, Jaeger, Caterpillar, Barbar Green; Scraper-self- propelled, hard tail end dump, articulating off-road equipment- under 45 yards; Subgrader trimmer; Tractors, backhoe over 75 hp; Transfer material service machine-shuttle buggy, Blaw Knox- Roadtec; Truck Crane oiler/driver-100 tons and over; Truck Mount Portable Conveyor; Yo Yo pay

GROUP 3 - Conveyors; Cranes through 19 tons with attachments; Crane-A-frame over 10 tons; Drill oilers-auger type, truck or crane mount; Dozer-D-9 and under; Forklift-3000 lbs. and over with attachments; Horizontal/directional drill locator; Outside Hoists-(elevators and manlifts), air tuggers, strato tower bucket elevators; Hydralifts/boom trucks over 10 tons; Loaders-elevating type, belt; Motor patrol grader-nonfinishing; Plant oiler- asphalt, crusher; Pump-Concrete; Roller, plant mix or multi-lfit materials; Saws-concrete; Scrapers, concrete and carry all; Service engineers-equipment; Trenching machines; Truck crane oiler/driver under 100 tons; Tractors, backhoe under 75 hp

GROUP 4 - Assistant Engineer; Bobcat; Brooms; Compressor; Concrete Finish Machine-laser screed; Cranes A-frame 10 tons and under; Elevator and manlift (permanent and shaft type); Forklifts-under 3000 lbs. with attachments; Gradechecker, stakehop; Hydralifts/boom trucks, 10 tons and under; Oil distributors, blower distribution and mulch seeding operator; Pavement breaker; Posthole digger-mechanical; Power plant; Pumps-water; Rigger and Bellman; Roller-other than plant mix; Wheel Tractors, farmall type; Shotcrete/gunite equipment operator

FOOTNOTE A- Reduced rates may be paid on the following:

1. Projects involving work on structures such as buildings and bridges whose total value is less than \$1.5 million excluding mechanical, electrical, and utility portions of the contract.
2. Projects of less than \$1 million where no building is involved. Surfacing and paving included, but utilities excluded.
3. Marine projects (docks, wharfs, etc.) less than \$150,000.

HANDLING OF HAZARDOUS WASTE MATERIALS: Personnel in all craft classifications subject to working inside a federally designated hazardous perimeter shall be eligible for compensation in accordance with the following group schedule relative to the level of hazardous waste as outlined in the specific hazardous waste project site safety plan.

H-1 Base wage rate when on a hazardous waste site when not outfitted with protective clothing, Class "D" Suit - Base wage rate plus \$.50 per hour.

H-2 Class "C" Suit - Base wage rate plus \$1.00 per hour.

H-3 Class "B" Suit - Base wage rate plus \$1.50 per hour.

H-4 Class "A" Suit - Base wage rate plus \$2.00 per hour.

 ENGI0701-002 01/01/2018

CLARK, COWLITZ, KLICKITAT, PACIFIC (SOUTH), SKAMANIA, AND WAHAKIYAKUM COUNTIES

POWER EQUIPMENT OPERATORS: ZONE 1

| | Rates | Fringes |
|--------------------------|----------|---------|
| POWER EQUIPMENT OPERATOR | | |
| GROUP 1..... | \$ 41.65 | 14.35 |
| GROUP 1A..... | \$ 43.73 | 14.35 |
| GROUP 1B..... | \$ 45.82 | 14.35 |
| GROUP 2..... | \$ 39.74 | 14.35 |
| GROUP 3..... | \$ 38.59 | 14.35 |
| GROUP 4..... | \$ 37.51 | 14.35 |
| GROUP 5..... | \$ 36.27 | 14.35 |
| GROUP 6..... | \$ 33.05 | 14.35 |

Zone Differential (add to Zone 1 rates):

Zone 2 - \$3.00

Zone 3 - \$6.00

For the following metropolitan counties: MULTNOMAH; CLACKAMAS; MARION; WASHINGTON; YAMHILL; AND COLUMBIA; CLARK; AND COWLITZ COUNTY, WASHINGTON WITH MODIFICATIONS AS INDICATED:

All jobs or projects located in Multnomah, Clackamas and Marion Counties, West of the western boundary of Mt. Hood National Forest and West of Mile Post 30 on Interstate 84 and West of Mile Post 30 on State Highway 26 and West of Mile Post 30 on Highway 22 and all jobs or projects located in Yamhill County, Washington County and Columbia County and all jobs or projects located in Clark & Cowlitz County, Washington except that portion of Cowlitz County in the Mt. St. Helens "Blast Zone" shall receive Zone I pay for all classifications.

All jobs or projects located in the area outside the identified boundary above, but less than 50 miles from the Portland City Hall shall receive Zone II pay for all classifications.

All jobs or projects located more than 50 miles from the Portland City Hall, but outside the identified border above, shall receive Zone III pay for all classifications.

For the following cities: ALBANY; BEND; COOS BAY; EUGENE; GRANTS PASS; KLAMATH FALLS; MEDFORD; ROSEBURG

All jobs or projects located within 30 miles of the respective city hall of the above mentioned cities shall receive Zone I pay for all classifications.

All jobs or projects located more than 30 miles and less than 50 miles from the respective city hall of the above mentioned cities shall receive Zone II pay for all classifications.

All jobs or projects located more than 50 miles from the respective city hall of the above mentioned cities shall receive Zone III pay for all classifications.

POWER EQUIPMENT OPERATORS CLASSIFICATIONS

Group 1

Concrete Batch Plant and or Wet mix three (3) units or more; Crane, Floating one hundred and fifty (150) ton but less than two hundred and fifty (250) ton; Crane, two hundred (200) ton through two hundred ninety nine (299) ton with two hundred foot (200') boom or less (including jib, inserts and/or attachments); Crane, ninety (90) ton through one hundred ninety nine (199) ton with over two hundred (200') boom Including jib, inserts and/or attachments); Crane, Tower Crane with one hundred seventy five foot (175') tower or less and with less than two hundred foot (200') jib; Crane, Whirley ninety (90) ton and over; Helicopter when used in erecting work

Group 1A

Crane, floating two hundred fifty (250) ton and over; Crane, two hundred (200) ton through two hundred ninety nine (299) ton, with over two hundred foot (200') boom (including jib, inserts and/or attachments); Crane, three hundred (300) ton through three hundred ninety nine (399) ton; Crane, Tower Crane with over one hundred seventy five foot (175') tower or over two hundred foot (200') jib; Crane, tower Crane on rail system or 2nd tower or more in work radius

Group 1B

Crane, three hundred (300) ton through three hundred ninety nine (399) ton, with over two hundred foot (200') boom (including jib, inserts and/or attachments); Floating crane, three hundred fifty (350) ton and over; Crane, four hundred (400) ton and over

Group 2

Asphalt Plant (any type); Asphalt Roto-Mill, pavement profiler eight foot (8') lateral cut and over; Auto Grader or "Trimmer"; Blade, Robotic; Bulldozer, Robotic Equipment (any type); Bulldozer, over one hundred twenty thousand (120,000) lbs. and above; Concrete Batch Plant and/or Wet Mix one (1) and two (2) drum; Concrete Diamond Head Profiler; Canal Trimmer; Concrete, Automatic Slip Form Paver (Assistant to the Operator required); Crane, Boom Truck fifty (50) ton and with over one hundred fifty foot (150') boom and over; Crane, Floating (derrick barge) thirty (30) ton but less than one hundred fifty (150) ton; Crane, Cableway twenty-five (25) ton and over; Crane, Floating Clamshell three (3) cu. Yds. And over; Crane, ninety (90) ton through one hundred ninety nine (199) ton up to and including two hundred foot (200') of boom (including jib inserts and/or attachments); Crane, fifty (50) ton through eighty nine (89) ton with over one hundred fifty foot (150') boom (including jib inserts and/or attachments); Crane, Whirley under ninety (90) ton; Crusher Plant; Excavator over one hundred thirty thousand (130,000) lbs.; Loader one hundred twenty thousand (120,000) lbs. and above; Remote Controlled Earth Moving Equipment; Shovel, Dragline, Clamshell, five (5) cu. Yds. And over; Underwater Equipment remote or otherwise, when used in construction work; Wheel Excavator any size

Group 3

Bulldozer, over seventy thousand (70,000) lbs. up to and including one hundred twenty thousand (120,000) lbs.; Crane, Boom Truck fifty (50) ton and over with less than one hundred fifty foot (150') boom; Crane, fifty (50) ton through eighty nine (89) ton with one hundred fifty foot (150') boom or less (including jib inserts and/or attachments); Crane, Shovel, Dragline or Clamshell three (3) cu. yds. but less than five (5) cu. Yds.; Excavator over eighty thousand (80,000) lbs. through one hundred thirty thousand (130,000) lbs.; Loader sixty thousand (60,000) lbs. and less than one hundred twenty thousand (120,000) lbs.

Group 4

Asphalt, Screed; Asphalt Paver; Asphalt Roto-Mill, pavement profiler, under eight foot (8') lateral cut; Asphalt, Material Transfer Vehicle Operator; Back Filling Machine; Backhoe, Robotic, track and wheel type up to and including twenty thousand (20,000) lbs. with any attachments; Blade (any type); Boatman; Boring Machine; Bulldozer over twenty thousand (20,000) lbs. and more than one hundred (100) horse up to seventy thousand (70,000) lbs.; Cable-Plow (any type); Cableway up to twenty five (25) ton; Cat Drill (John Henry); Chippers; Compactor, multi-engine; Compactor, Robotic; Compactor with blade self-propelled; Concrete, Breaker; Concrete, Grout Plant; Concrete, Mixer Mobile; Concrete, Paving Road Mixer; Concrete, Reinforced Tank Banding Machine; Crane, Boom Truck twenty (20) ton and under fifty (50) ton; Crane, Bridge Locomotive, Gantry and Overhead; Crane, Carry Deck; Crane, Chicago Boom and similar types; Crane, Derrick Operator, under one hundred (100) ton; Crane, Floating Clamshell, Dragline, etc. Operator, under three (3) cu. yds. Or less than thirty (30) ton; Crane, under fifty (50) ton; Crane, Quick Tower under one hundred foot (100') in height and less than one hundred fifty foot (150') jib (on rail included); Diesel-Electric Engineer (Plant or Floating); Directional Drill over twenty thousand (20,000) lbs. pullback; Drill Cat Operator; Drill Doctor and/or Bit Grinder; Driller, Percussion, Diamond, Core, Cable, Rotary and similar type; Excavator Operator over twenty thousand (20,000) lbs. through eighty thousand (80,000) lbs.; Generator Operator; Grade-all; Guardrail Machines, i.e. punch, auger, etc.; Hammer Operator (Piledriver); Hoist, stiff leg, guy derrick or similar type, fifty (50) ton and over; Hoist, two (2) drums or more; Hydro Axe (loader mounted or similar type); Jack Operator, Elevating Barges, Barge Operator, self-unloading; Loader Operator, front end and overhead, twenty five thousand (25,000) lbs. and less than sixty thousand (60,000) lbs.; Log Skidders; Piledriver Operator (not crane type); Pipe, Bending, Cleaning, Doping and Wrapping Machines; Rail, Ballast Tamper Multi-Purpose; Rubber-tired Dozers and Pushers; Scraper, all types; Side-Boom; Skip Loader, Drag Box; Strump Grinder (loader mounted or similar type); Surface Heater and Planer; Tractor, rubber-tired, over fifty (50) HP Flywheel; Trenching Machine three foot (3') depth and deeper; Tub Grinder (used for wood debris); Tunnel Boring Machine Mechanic; Tunnel, Mucking Machine; Ultra High Pressure Water Jet Cutting Tool System Operator; Vacuum Blasting Machine Operator; Water pulls, Water wagons

Group 5

Asphalt, Extrusion Machine; Asphalt, Roller (any asphalt mix); Asphalt, Roto-Mill pavement profiler ground man; Bulldozer, twenty thousand (20,000) lbs. or less, or one hundred (100) horse or less; Cement Pump; Chip Spreading Machine; Churn Drill and Earth Boring Machine; Compactor, self-propelled without blade; Compressor, (any power) one thousand two hundred fifty (1,250) cu. ft. and over, total capacity; Concrete, Batch Plant Quality control; Concrete, Combination Mixer and compressor operator, gunite work; Concrete, Curb Machine, Mechanical Berm, Curb and/or Curb and Gutter; Concrete, Finishing Machine; Concrete, Grouting Machine; Concrete, Internal Full Slab Vibrator Operator; Concrete, Joint Machine; Concrete, Mixer single drum, any capacity; Concrete, Paving Machine eight foot (8') or less; Concrete, Planer; Concrete, Pump; Concrete, Pump Truck; Concrete, Pumpcrete Operator (any type); Concrete, Slip Form Pumps, power driven hydraulic lifting device for concrete forms; Conveyored Material Hauler; Crane, Boom Truck under twenty (20) tons; Crane, Boom Type lifting device, five (5) ton capacity or less; Drill, Directional type less than twenty thousand (20,000) lbs. pullback; Fork Lift, over ten (10) ton or Robotic; Helicopter Hoist; Hoist Operator, single drum; Hydraulic Backhoe track type up to and including twenty thousand (20,000) lbs.; Hydraulic Backhoe wheel type (any make); Laser Screed; Loaders, rubber-tired type, less than twenty five thousand (25,000) lbs.; Pavement Grinder and/or Grooving Machine (riding type); Pipe, cast in place Pipe Laying Machine; Pulva-Mixer or similar types; Pump Operator, more than five (5) pumps (any size); Rail, Ballast Compactor, Regulator, or Tamper machines; Service Oiler (Greaser); Sweeper Self-Propelled; Tractor, Rubber-Tired, fifty (50) HP flywheel and under; Trenching Machine Operator, maximum digging capacity three foot (3') depth; Tunnel, Locomotive, Dinkey; Tunnel, Power Jumbo setting slip forms, etc.

Group 6

Asphalt, Pugmill (any type); Asphalt, Raker; Asphalt, Truck Mounted Asphalt Spreader, with Screed; Auger Oiler; Boatman; Bobcat, skid steed (less than one (1) yard); Broom, self-propelled; Compressor Operator (any power) under 1,250 cu. ft. total capacity; Concrete Curing Machine (riding type); Concrete Saw; Conveyor Operator or Assistant; Crane, Tugger; Crusher Feederman; Crusher Oiler; Deckhand; Drill, Directional Locator; Fork Lift; Grade Checker; Guardrail Punch Oiler; Hydrographic Seeder Machine, straw, pulp or seed; Hydrostatic Pump Operator; Mixer Box (CTB, dry batch, etc.); Oiler; Plant Oiler; Pump (any power); Rail, Brakeman, Switchman, Motorman; Rail, Tamping Machine, mechanical, self-propelled; Rigger; Roller grading (not asphalt); Truck, Crane Oiler-Driver

IRON0014-005 07/01/2018

ADAMS, ASOTIN, BENTON, COLUMBIA, DOUGLAS, FERRY, FRANKLIN,
GARFIELD, GRANT, LINCOLN, OKANOGAN, PEND ORIELLE, SPOKANE,
STEVENS, WALLA WALLA AND WHITMAN COUNTIES

| | Rates | Fringes |
|-----------------|----------|---------|
| IRONWORKER..... | \$ 33.18 | 27.82 |

IRON0029-002 05/01/2018

CLARK, COWLITZ, KLICKITAT, PACIFIC, SKAMANIA, AND WAHKAIKUM
COUNTIES

| | Rates | Fringes |
|-----------------|----------|---------|
| IRONWORKER..... | \$ 37.00 | 27.87 |

IRON0086-002 07/01/2018

YAKIMA, KITTITAS AND CHELAN COUNTIES

| | Rates | Fringes |
|-----------------|----------|---------|
| IRONWORKER..... | \$ 33.18 | 27.82 |

IRON0086-004 07/01/2018

CLALLAM, GRAYS HARBOR, ISLAND, JEFFERSON, KING, KITSAP, LEWIS,
MASON, PIERCE, SKAGIT, SNOHOMISH, THURSTON, AND WHATCOM COUNTIES

| | Rates | Fringes |
|-----------------|----------|---------|
| IRONWORKER..... | \$ 40.81 | 28.22 |

LABO0238-004 06/01/2018

PASCO AREA: ADAMS, BENTON, COLUMBIA, DOUGLAS (East of 120th Meridian), FERRY, FRANKLIN, GRANT, OKANOGAN, WALLA WALLA

SPOKANE AREA: ASOTIN, GARFIELD, LINCOLN, PEND OREILLE, SPOKANE, STEVENS & WHITMAN COUNTIES

| | Rates | Fringes |
|-------------------|----------|---------|
| LABORER (PASCO) | | |
| GROUP 1..... | \$ 24.84 | 12.35 |
| GROUP 2..... | \$ 26.94 | 12.35 |
| GROUP 3..... | \$ 27.21 | 12.35 |
| GROUP 4..... | \$ 27.48 | 12.35 |
| GROUP 5..... | \$ 27.76 | 12.35 |
| LABORER (SPOKANE) | | |
| GROUP 1..... | \$ 24.74 | 12.45 |
| GROUP 2..... | \$ 26.84 | 12.45 |
| GROUP 3..... | \$ 27.11 | 12.45 |
| GROUP 4..... | \$ 27.38 | 12.45 |
| GROUP 5..... | \$ 27.66 | 12.45 |

Zone Differential (Add to Zone 1 rate): \$2.00

BASE POINTS: Spokane, Pasco, Lewiston

Zone 1: 0-45 radius miles from the main post office.

Zone 2: 45 radius miles and over from the main post office.

LABORERS CLASSIFICATIONS

GROUP 1: Flagman; Landscape Laborer; Scaleman; Traffic Control Maintenance Laborer (to include erection and maintenance of barricades, signs and relief of flagperson); Window Washer/Cleaner (detail cleanup, such as, but not limited to cleaning floors, ceilings, walls, windows, etc. prior to final acceptance by the owner)

GROUP 2: Asbestos Abatement Worker; Brush Hog Feeder; Carpenter Tender; Cement Handler; Clean-up Laborer; Concrete Crewman (to include stripping of forms, hand operating jacks on slip form construction, application of concrete curing compounds, pumpcrete machine, signaling, handling the nozzle of squeezecrete or similar machine, 6 inches and smaller); Confined Space Attendant; Concrete Signalman; Crusher Feeder; Demolition (to include clean-up, burning, loading, wrecking and salvage of all material); Dumpman; Fence Erector; Firewatch; Form Cleaning Machine Feeder, Stacker; General Laborer; Grout Machine Header Tender; Guard Rail (to include guard rails, guide and reference posts, sign posts, and right-of-way markers); Hazardous Waste Worker, Level D (no respirator is used and skin protection is minimal); Miner, Class "A" (to include all bull gang, concrete crewman, dumpman and pumpcrete

crewman, including distributing pipe, assembly & dismantle, and nipper); Nipper; Riprap Man; Sandblast Tailhoseman; Scaffold Erector (wood or steel); Stake Jumper; Structural Mover (to include separating foundation, preparation, cribbing, shoring, jacking and unloading of structures); Tailhoseman (water nozzle); Timber Bucker and Faller (by hand); Track Laborer (RR); Truck Loader; Well-Point Man; All Other Work Classifications Not Specially Listed Shall Be Classified As General Laborer

GROUP 3: Asphalt Roller, walking; Cement Finisher Tender; Concrete Saw, walking; Demolition Torch; Dope Pot Firemen, non-mechanical; Driller Tender (when required to move and position machine); Form Setter, Paving; Grade Checker using level; Hazardous Waste Worker, Level C (uses a chemical "splash suit" and air purifying respirator); Jackhammer Operator; Miner, Class "B" (to include brakeman, finisher, vibrator, form setter); Nozzleman (to include squeeze and flo-crete nozzle); Nozzleman, water, air or steam; Pavement Breaker (under 90 lbs.); Pipelayer, corrugated metal culvert; Pipelayer, multi-plate; Pot Tender; Power Buggy Operator; Power Tool Operator, gas, electric, pneumatic; Railroad Equipment, power driven, except dual mobile power spiker or puller; Railroad Power Spiker or Puller, dual mobile; Rodder and Spreader; Tamper (to include operation of Barco, Essex and similar tampers); Trencher, Shawnee; Tugger Operator; Wagon Drills; Water Pipe Liner; Wheelbarrow (power driven)

GROUP 4: Air and Hydraulic Track Drill; Asphalt Raker; Brush Machine (to include horizontal construction joint cleanup brush machine, power propelled); Caisson Worker, free air; Chain Saw Operator and Faller; Concrete Stack (to include laborers when laborers working on free standing concrete stacks for smoke or fume control above 40 feet high); Guniting (to include operation of machine and nozzle); Hazardous Waste Worker, Level B (uses same respirator protection as Level A. A supplied air line is provided in conjunction with a chemical "splash suit"); High Scaler; Laser Beam Operator (to include grade checker and elevation control); Miner, Class C (to include miner, nozzleman for concrete, laser beam operator and rigger on tunnels); Monitor Operator (air track or similar mounting); Mortar Mixer; Nozzleman (to include jet blasting nozzleman, over 1,200 lbs., jet blast machine power propelled, sandblast nozzle); Pavement Breaker (90 lbs. and over); Pipelayer (to include working topman, caulker, collarman, jointer, mortarman, rigger, jacker, shorer, valve or meter installer); Pipewrapper; Plasterer Tender; Vibrators (all)

GROUP 5 - Drills with Dual Masts; Hazardous Waste Worker, Level A (utilizes a fully encapsulated suit with a self-contained breathing apparatus or a supplied air line); Miner Class "D", (to include raise and shaft miner, laser beam operator on riases and shafts)

LABO0238-006 06/01/2018

COUNTIES EAST OF THE 120TH MERIDIAN: ADAMS, ASOTIN, BENTON, CHELAN, COLUMBIA, DOUGLAS, FERRY, FRANKLIN, GARFIELD, GRANT, LINCOLN, OKANOGAN, PEND OREILLE, STEVENS, SPOKANE, WALLA WALLA, WHITMAN

| | Rates | Fringes |
|------------------|----------|---------|
| Hod Carrier..... | \$ 27.75 | 12.25 |

LABO0242-003 06/01/2019

KING COUNTY

| | Rates | Fringes |
|---------------|----------|---------|
| LABORER | | |
| GROUP 1..... | \$ 27.10 | 11.94 |
| GROUP 2A..... | \$ 31.03 | 11.94 |
| GROUP 3..... | \$ 38.78 | 11.94 |
| GROUP 4..... | \$ 39.72 | 11.94 |
| GROUP 5..... | \$ 40.36 | 11.94 |
| Group 6..... | \$ 40.36 | 12.04 |

BASE POINTS: BELLINGHAM, MT. VERNON, EVERETT, SEATTLE, KENT, TACOMA, OLYMPIA, CENTRALIA, ABERDEEN, SHELTON, PT. TOWNSEND, PT. ANGELES, AND BREMERTON

- ZONE 1 - Projects within 25 radius miles of the respective city hall
- ZONE 2 - More than 25 but less than 45 radius miles from the respective city hall
- ZONE 3 - More than 45 radius miles from the respective city hall

ZONE DIFFERENTIAL (ADD TO ZONE 1 RATES):
 ZONE 2 - \$1.00
 ZONE 3 - \$1.30

BASE POINTS: CHELAN, SUNNYSIDE, WENATCHEE, AND YAKIMA

- ZONE 1 - Projects within 25 radius miles of the respective city hall
- ZONE 2 - More than 25 radius miles from the respective city hall

ZONE DIFFERENTIAL (ADD TO ZONE 1 RATES):
 ZONE 2 - \$2.25

LABORERS CLASSIFICATIONS

GROUP 1: Landscaping and Planting; Watchman; Window Washer/Cleaner (detail clean-up, such as but not limited to cleaning floors, ceilings, walls, windows, etc., prior to final acceptance by the owner)

GROUP 2A: Batch Weighman; Crusher Feeder; Fence Laborer; Flagman; Pilot Car

GROUP 3: General Laborer; Air, Gas, or Electric Vibrating Screed; Asbestos Abatement Laborer; Ballast Regulator Machine; Brush Cutter; Brush Hog Feeder; Burner; Carpenter Tender; Cement Finisher Tender; Change House or Dry Shack; Chipping Gun (under 30 lbs.); Choker Setter; Chuck Tender; Clean-up Laborer; Concrete Form Stripper; Curing Laborer; Demolition (wrecking and moving including charred material); Ditch Digger; Dump Person; Fine Graders; Firewatch; Form Setter; Gabian Basket Builders; Grout Machine Tender; Grinders; Guardrail Erector; Hazardous Waste Worker (Level C: uses a chemical "splash suit" and air purifying respirator); Maintenance Person; Material Yard Person; Pot Tender; Rip Rap Person; Riggers; Scale Person; Sloper Sprayer; Signal Person; Stock Piler; Stake Hopper; Toolroom Man (at job site); Topper-Tailer; Track Laborer; Truck Spotter; Vinyl Seamer

GROUP 4: Cement Dumper-Paving; Chipping Gun (over 30 lbs.); Clary Power Spreader; Concrete Dumper/Chute Operator; Concrete Saw Operator; Drill Operator (hydraulic, diamond, aiartrac); Faller and Bucker Chain Saw; Grade Checker and Transit Person; Groutmen (pressure) including post tension beams; Hazardous Waste Worker (Level B: uses same respirator protection as Level A. A supplied air line is provided in conjunction with a chemical "splash suit"); High Scaler; Jackhammer; Laserbeam Operator; Manhole Builder-Mudman; Nozzleman (concrete pump, green cutter when using combination of high pressure air and water on concrete and rock, sandblast, gunite, shotcrete, water blaster, vacuum blaster); Pavement Breaker; Pipe Layer and Caulker; Pipe Pot Tender; Pipe Reliner (not insert type); Pipe Wrapper; Power Jacks; Railroad Spike Puller-Power; Raker-Asphalt; Rivet Buster; Rodder; Sloper (over 20 ft); Spreader (concrete); Tamper and Similar electric, air and glas operated tool; Timber Person-sewer (lagger shorer and cribber); Track Liner Power; Tugger Operator; Vibrator; Well Point Laborer

GROUP 5: Caisson Worker; Mortarman and Hodcarrier; Powderman; Re-Timberman; Hazardous Waste Worker (Level A: utilizes a fully encapsulated suit with a self-contained breathing apparatus or a supplied air line).

Group 6: Miner

LABO0252-010 06/01/2019

CLALLAM, GRAYS HARBOR, JEFFERSON, KITSAP, LEWIS, MASON, PACIFIC
(EXCLUDING SOUTHWEST), PIERCE, AND THURSTON COUNTIES

| | Rates | Fringes |
|--------------|----------|---------|
| LABORER | | |
| GROUP 1..... | \$ 27.10 | 11.94 |
| GROUP 2..... | \$ 31.03 | 11.94 |
| GROUP 3..... | \$ 38.78 | 11.94 |
| GROUP 4..... | \$ 39.72 | 11.94 |
| GROUP 5..... | \$ 40.36 | 11.94 |

BASE POINTS: BELLINGHAM, MT. VERNON, EVERETT, SEATTLE, KENT,
TACOMA, OLYMPIA, CENTRALIA, ABERDEEN, SHELTON, PT.
TOWNSEND, PT. ANGELES, AND BREMERTON

ZONE 1 - Projects within 25 radius miles of the respective
city hall
 ZONE 2 - More than 25 but less than 45 radius miles from the
respective city hall
 ZONE 3 - More than 45 radius miles from the respective city
hall

ZONE DIFFERENTIAL (ADD TO ZONE 1 RATES):
 ZONE 2 - \$1.00
 ZONE 3 - \$1.30

BASE POINTS: CHELAN, SUNNYSIDE, WENATCHEE, AND YAKIMA

ZONE 1 - Projects within 25 radius miles of the respective
city hall
 ZONE 2 - More than 25 radius miles from the respective city
hall

ZONE DIFFERENTIAL (ADD TO ZONE 1 RATES):
 ZONE 2 - \$2.25

LABORERS CLASSIFICATIONS

GROUP 1: Landscaping and Planting; Watchman; Window
Washer/Cleaner (detail clean-up, such as but not limited to
cleaning floors, ceilings, walls, windows, etc., prior to
final acceptance by the owner)

 GROUP 2: Batch Weighman; Crusher Feeder; Fence Laborer;
Flagman; Pilot Car

GROUP 3: General Laborer; Air, Gas, or Electric Vibrating Screed; Asbestos Abatement Laborer; Ballast Regulator Machine; Brush Cutter; Brush Hog Feeder; Burner; Carpenter Tender; Cement Finisher Tender; Change House or Dry Shack; Chipping Gun (under 30 lbs.); Choker Setter; Chuck Tender; Clean-up Laborer; Concrete Form Stripper; Curing Laborer; Demolition (wrecking and moving including charred material); Ditch Digger; Dump Person; Fine Graders; Firewatch; Form Setter; Gabian Basket Builders; Grout Machine Tender; Grinders; Guardrail Erector; Hazardous Waste Worker (Level C: uses a chemical "splash suit" and air purifying respirator); Maintenance Person; Material Yard Person; Pot Tender; Rip Rap Person; Riggers; Scale Person; Sloper Sprayer; Signal Person; Stock Piler; Stake Hopper; Toolroom Man (at job site); Topper-Tailer; Track Laborer; Truck Spotter; Vinyl Seamer

GROUP 4: Cement Dumper-Paving; Chipping Gun (over 30 lbs.); Clary Power Spreader; Concrete Dumper/Chute Operator; Concrete Saw Operator; Drill Operator (hydraulic, diamond, aiartrac); Faller and Bucker Chain Saw; Groutmen (pressure) including post tension beams; Hazardous Waste Worker (Level B: uses same respirator protection as Level A. A supplied air line is provided in conjunction with a chemical "splash suit"); Jackhammer; Laserbeam Operator; Manhole Builder-Mudman; Nozzleman (concrete pump, green cutter when using combination of high pressure air and water on concrete and rock, sandblast, gunite, shotcrete, water blaster, vacuum blaster); Pavement Breaker; Pipe Layer and Caulker; Pipe Pot Tender; Pipe Reliner (not insert type); Pipe Wrapper; Power Jacks; Railroad Spike Puller-Power; Raker-Asphalt; Rivet Buster; Rodder; Sloper (over 20 ft); Spreader (concrete); Tamper and Similar electric, air and glas operated tool; Timber Person-sewer (lagger shorer and cribber); Track Liner Power; Tugger Operator; Vibrator; Well Point Laborer

GROUP 5: Caisson Worker; Miner; Mortarman and Hodcarrier; Grade Checker and Transit Person; High Scaler; Powderman; Re-Timberman; Hazardous Waste Worker (Level A: utilizes a fully encapsulated suit with a self-contained breathing apparatus or a supplied air line).

LABO0292-008 06/01/2019

ISLAND, SAN JUAN, SKAGIT, SNOHOMISH, AND WHATCOM COUNTIES

| | Rates | Fringes |
|--------------|----------|---------|
| LABORER | | |
| GROUP 1..... | \$ 27.10 | 11.94 |
| GROUP 2..... | \$ 31.03 | 11.94 |
| GROUP 3..... | \$ 38.78 | 11.94 |
| GROUP 4..... | \$ 39.72 | 11.94 |
| GROUP 5..... | \$ 40.36 | 11.94 |

BASE POINTS: BELLINGHAM, MT. VERNON, EVERETT, SEATTLE, KENT, TACOMA, OLYMPIA, CENTRALIA, ABERDEEN, SHELTON, PT. TOWNSEND, PT. ANGELES, AND BREMERTON

ZONE 1 - Projects within 25 radius miles of the respective city hall
 ZONE 2 - More than 25 but less than 45 radius miles from the respective city hall
 ZONE 3 - More than 45 radius miles from the respective city hall

ZONE DIFFERENTIAL (ADD TO ZONE 1 RATES):
 ZONE 2 - \$1.00
 ZONE 3 - \$1.30

BASE POINTS: CHELAN, SUNNYSIDE, WENATCHEE, AND YAKIMA

ZONE 1 - Projects within 25 radius miles of the respective city hall
 ZONE 2 - More than 25 radius miles from the respective city hall

ZONE DIFFERENTIAL (ADD TO ZONE 1 RATES):
 ZONE 2 - \$2.25

LABORERS CLASSIFICATIONS

GROUP 1: Landscaping and Planting; Watchman; Window Washer/Cleaner (detail clean-up, such as but not limited to cleaning floors, ceilings, walls, windows, etc., prior to final acceptance by the owner)

 GROUP 2: Batch Weighman; Crusher Feeder; Fence Laborer; Flagman; Pilot Car

GROUP 3: General Laborer; Air, Gas, or Electric Vibrating Screed; Asbestos Abatement Laborer; Ballast Regulator Machine; Brush Cutter; Brush Hog Feeder; Burner; Carpenter Tender; Cement Finisher Tender; Change House or Dry Shack; Chipping Gun (under 30 lbs.); Choker Setter; Chuck Tender; Clean-up Laborer; Concrete Form Stripper; Curing Laborer; Demolition (wrecking and moving including charred material); Ditch Digger; Dump Person; Fine Graders; Firewatch; Form Setter; Gabian Basket Builders; Grout Machine Tender; Grinders; Guardrail Erector; Hazardous Waste Worker (Level C: uses a chemical "splash suit" and air purifying respirator); Maintenance Person; Material Yard Person; Pot Tender; Rip Rap Person; Riggers; Scale Person; Sloper Sprayer; Signal Person; Stock Piler; Stake Hopper; Toolroom Man (at job site); Topper-Tailer; Track Laborer; Truck Spotter; Vinyl Seamer

GROUP 4: Cement Dumper-Paving; Chipping Gun (over 30 lbs.); Clary Power Spreader; Concrete Dumper/Chute Operator; Concrete Saw Operator; Drill Operator (hydraulic, diamond, aiartrac); Faller and Bucker Chain Saw; Grade Checker and Transit Person; Groutmen (pressure) including post tension beams; Hazardous Waste Worker (Level B: uses same respirator protection as Level A. A supplied air line is provided in conjunction with a chemical "splash suit"); High Scaler; Jackhammer; Laserbeam Operator; Manhole Builder-Mudman; Nozzleman (concrete pump, green cutter when using combination of high pressure air and water on concrete and rock, sandblast, gunite, shotcrete, water blaster, vacuum blaster); Pavement Breaker; Pipe Layer and Caulker; Pipe Pot Tender; Pipe Reliner (not insert type); Pipe Wrapper; Power Jacks; Railroad Spike Puller-Power; Raker-Asphalt; Rivet Buster; Rodder; Sloper (over 20 ft); Spreader (concrete); Tamper and Similar electric, air and glas operated tool; Timber Person-sewer (lagger shorer and cribber); Track Liner Power; Tugger Operator; Vibrator; Well Point Laborer

GROUP 5: Caisson Worker; Miner; Mortarman and Hodcarrier; Powderman; Re-Timberman; Hazardous Waste Worker (Level A: utilizes a fully encapsulated suit with a self-contained breathing apparatus or a supplied air line).

LABO0335-001 06/01/2018

CLARK, COWLITZ, KLICKITAT, PACIFIC (SOUTH OF A STRAIGHT LINE MADE BY EXTENDING THE NORTH BOUNDARY LINE OF WAHAKIYAKUM COUNTY WEST TO THE PACIFIC OCEAN), SKAMANIA AND WAHAKIYAKUM COUNTIES

| | Rates | Fringes |
|--------------|----------|---------|
| Laborers: | | |
| ZONE 1: | | |
| GROUP 1..... | \$ 31.72 | 11.49 |
| GROUP 2..... | \$ 32.38 | 11.49 |
| GROUP 3..... | \$ 32.87 | 11.49 |
| GROUP 4..... | \$ 33.29 | 11.49 |
| GROUP 5..... | \$ 28.98 | 11.49 |
| GROUP 6..... | \$ 26.31 | 11.49 |
| GROUP 7..... | \$ 22.78 | 11.49 |

Zone Differential (Add to Zone 1 rates):

Zone 2 \$ 0.65

Zone 3 - 1.15

Zone 4 - 1.70

Zone 5 - 2.75

BASE POINTS: LONGVIEW AND VANCOUVER

ZONE 1: Projects within 30 miles of the respective city all.

ZONE 2: More than 30 miles but less than 40 miles from the respective city hall.

ZONE 3: More than 40 miles but less than 50 miles from the respective city hall.

ZONE 4: More than 50 miles but less than 80 miles from the respective city hall.

ZONE 5: More than 80 miles from the respective city hall.

LABORERS CLASSIFICATIONS

GROUP 1: Asphalt Plant Laborers; Asphalt Spreaders; Batch Weighman; Broomers; Brush Burners and Cutters; Car and Truck Loaders; Carpenter Tender; Change-House Man or Dry Shack Man; Choker Setter; Clean-up Laborers; Curing, Concrete; Demolition, Wrecking and Moving Laborers; Dumpers, road oiling crew; Dumpmen (for grading crew); Elevator Feeders; Median Rail Reference Post, Guide Post, Right of Way Marker; Fine Graders; Fire Watch; Form Strippers (not swinging stages); General Laborers; Hazardous Waste Worker; Leverman or Aggregate Spreader (Flaherty and similar types); Loading Spotters; Material Yard Man (including electrical); Pittsburgh Chipper Operator or Similar Types; Railroad Track Laborers; Ribbon Setters (including steel forms); Rip Rap Man (hand placed); Road Pump Tender; Sewer Labor; Signalman; Skipman; Slopers; Spraymen; Stake Chaser; Stockpiler; Tie Back Shoring; Timber Faller and Bucker (hand labor); Toolroom Man (at job site); Tunnel Bullgang (above ground); Weight-Man- Crusher (aggregate when used)

GROUP 2: Applicator (including pot power tender for same), applying protective material by hand or nozzle on utility lines or storage tanks on project; Brush Cutters (power saw); Burners; Choker Splicer; Clary Power Spreader and similar types; Clean- up Nozzleman-Green Cutter (concrete, rock, etc.); Concrete Power Buggyman; Concrete Laborer; Crusher Feeder; Demolition and Wrecking Charred Materials; Gunite Nozzleman Tender; Gunite or Sand Blasting Pot Tender; Handlers or Mixers of all Materials of an irritating nature (including cement and lime); Tool Operators (includes but not limited to: Dry Pack Machine; Jackhammer; Chipping Guns; Paving Breakers); Pipe Doping and Wrapping; Post Hole Digger, air, gas or electric; Vibrating Screed; Tampers; Sand Blasting (Wet); Stake-Setter; Tunnel-Muckers, Brakemen, Concrete Crew, Bullgang (underground)

GROUP 3: Asbestos Removal; Bit Grinder; Drill Doctor; Drill Operators, air tracks, cat drills, wagon drills, rubber-mounted drills, and other similar types including at crusher plants; Gunite Nozzleman; High Scalers, Strippers and Drillers (covers work in swinging stages, chairs or belts, under extreme conditions unusual to normal drilling, blasting, barring-down, or sloping and stripping); Manhole Builder; Powdermen; Concrete Saw Operator; Pwdermen; Power Saw Operators (Bucking and Falling); Pumpcrete Nozzlemen; Sand Blasting (Dry); Sewer Timberman; Track Liners, Anchor Machines, Ballast Regulators, Multiple Tampers, Power Jacks, Tugger Operator; Tunnel-Chuck Tenders, Nippers and Timbermen; Vibrator; Water Blaster

GROUP 4: Asphalt Raker; Concrete Saw Operator (walls); Concrete Nozzelman; Grade Checker; Pipelayer; Laser Beam (pipelaying)-applicable when employee assigned to move, set up, align; Laser Beam; Tunnel Miners; Motorman-Dinky Locomotive-Tunnel; Powderman-Tunnel; Shield Operator-Tunnel

GROUP 5: Traffic Flaggers

GROUP 6: Fence Builders

GROUP 7: Landscaping or Planting Laborers

LABO0335-019 06/01/2018

| | Rates | Fringes |
|------------------|----------|---------|
| Hod Carrier..... | \$ 31.72 | 11.49 |

LABO0348-003 06/01/2019

CHELAN, DOUGLAS (W OF 12TH MERIDIAN), KITTITAS, AND YAKIMA COUNTIES

| | Rates | Fringes |
|--------------|----------|---------|
| LABORER | | |
| GROUP 1..... | \$ 23.12 | 11.94 |
| GROUP 2..... | \$ 26.51 | 11.94 |
| GROUP 3..... | \$ 29.01 | 11.94 |
| GROUP 4..... | \$ 29.71 | 11.94 |
| GROUP 5..... | \$ 30.22 | 11.94 |

BASE POINTS: BELLINGHAM, MT. VERNON, EVERETT, SEATTLE, KENT, TACOMA, OLYMPIA, CENTRALIA, ABERDEEN, SHELTON, PT. TOWNSEND, PT. ANGELES, AND BREMERTON

ZONE 1 - Projects within 25 radius miles of the respective city hall
 ZONE 2 - More than 25 but less than 45 radius miles from the respective city hall
 ZONE 3 - More than 45 radius miles from the respective city hall

ZONE DIFFERENTIAL (ADD TO ZONE 1 RATES):
 ZONE 2 - \$1.00
 ZONE 3 - \$1.30

BASE POINTS: CHELAN, SUNNYSIDE, WENATCHEE, AND YAKIMA

ZONE 1 - Projects within 25 radius miles of the respective city hall
 ZONE 2 - More than 25 radius miles from the respective city hall

ZONE DIFFERENTIAL (ADD TO ZONE 1 RATES):
 ZONE 2 - \$2.25

LABORERS CLASSIFICATIONS

GROUP 1: Landscaping and Planting; Watchman; Window Washer/Cleaner (detail clean-up, such as but not limited to cleaning floors, ceilings, walls, windows, etc., prior to final acceptance by the owner)

 GROUP 2: Batch Weighman; Crusher Feeder; Fence Laborer; Flagman; Pilot Car

GROUP 3: General Laborer; Air, Gas, or Electric Vibrating Screed; Asbestos Abatement Laborer; Ballast Regulator Machine; Brush Cutter; Brush Hog Feeder; Burner; Carpenter Tender; Cement Finisher Tender; Change House or Dry Shack; Chipping Gun (under 30 lbs.); Choker Setter; Chuck Tender; Clean-up Laborer; Concrete Form Stripper; Curing Laborer; Demolition (wrecking and moving including charred material); Ditch Digger; Dump Person; Fine Graders; Firewatch; Form Setter; Gabian Basket Builders; Grout Machine Tender; Grinders; Guardrail Erector; Hazardous Waste Worker (Level C: uses a chemical "splash suit" and air purifying respirator); Maintenance Person; Material Yard Person; Pot Tender; Rip Rap Person; Riggers; Scale Person; Sloper Sprayer; Signal Person; Stock Piler; Stake Hopper; Toolroom Man (at job site); Topper-Tailer; Track Laborer; Truck Spotter; Vinyl Seamer

GROUP 4: Cement Dumper-Paving; Chipping Gun (over 30 lbs.); Clary Power Spreader; Concrete Dumper/Chute Operator; Concrete Saw Operator; Drill Operator (hydraulic, diamond, aiartrac); Faller and Bucker Chain Saw; Grade Checker and Transit Person; Groutmen (pressure) including post tension beams; Hazardous Waste Worker (Level B: uses same respirator protection as Level A. A supplied air line is provided in conjunction with a chemical "splash suit"); High Scaler; Jackhammer; Laserbeam Operator; Manhole Builder-Mudman; Nozzleman (concrete pump, green cutter when using combination of high pressure air and water on concrete and rock, sandblast, gunite, shotcrete, water blaster, vacuum blaster); Pavement Breaker; Pipe Layer and Caulker; Pipe Pot Tender; Pipe Reliner (not insert type); Pipe Wrapper; Power Jacks; Railroad Spike Puller-Power; Raker-Asphalt; Rivet Buster; Rodder; Sloper (over 20 ft); Spreader (concrete); Tamper and Similar electric, air and glas operated tool; Timber Person-sewer (lagger shorer and cribber); Track Liner Power; Tugger Operator; Vibrator; Well Point Laborer

GROUP 5: Caisson Worker; Miner; Mortarman and Hodcarrier; Powderman; Re-Timberman; Hazardous Waste Worker (Level A: utilizes a fully encapsulated suit with a self-contained breathing apparatus or a supplied air line).

PAIN0005-002 07/01/2018

STATEWIDE EXCEPT CLARK, COWLITZ, KLUCKITAT, PACIFIC (SOUTH),
SKAMANIA, AND WAHAKIAKUM COUNTIES

| | Rates | Fringes |
|---------------|----------|---------|
| Painters: | | |
| STRIPERS..... | \$ 30.50 | 15.73 |

PAIN0005-004 03/01/2009

CLALLAM, GRAYS HARBOR, ISLAND, JEFFERSON, KING, KITSAP, LEWIS,
MASON, PIERCE, SAN JUAN, SKAGIT, SNOHOMISH, THURSTON AND
WHATCOM COUNTIES

| | Rates | Fringes |
|--------------|----------|---------|
| PAINTER..... | \$ 20.82 | 7.44 |

* PAIN0005-006 07/01/2018

ADAMS, ASOTIN; BENTON AND FRANKLIN (EXCEPT HANFORD SITE);
CHELAN, COLUMBIA, DOUGLAS, FERRY, GARFIELD, GRANT, KITTITAS,
LINCOLN, OKANOGAN, PEND OREILLE, SPOKANE, STEVENS, WALLA WALLA,
WHITMAN AND YAKIMA COUNTIES

| | Rates | Fringes |
|---|----------|---------|
| PAINTER | | |
| Application of Cold Tar Products, Epoxies, Polyure thanes, Acids, Radiation Resistant Material, Water and Sandblasting..... | \$ 30.19 | 11.71 |
| Over 30'/Swing Stage Work.. | \$ 22.20 | 7.98 |
| Brush, Roller, Striping, Steam-cleaning and Spray.... | \$ 22.94 | 11.61 |
| Lead Abatement, Asbestos Abatement..... | \$ 21.50 | 7.98 |

*\$.70 shall be paid over and above the basic wage rates
listed for work on swing stages and high work of over 30
feet.

PAIN0055-003 07/01/2018

CLARK, COWLITZ, KLICKITAT, PACIFIC, SKAMANIA, AND WAHKIAKUM COUNTIES

| | Rates | Fringes |
|--|----------|---------|
| PAINTER | | |
| Brush & Roller..... | \$ 23.51 | 11.94 |
| High work - All work 60 ft. or higher..... | \$ 24.26 | 11.94 |
| Spray and Sandblasting..... | \$ 23.51 | 11.94 |

PAIN0055-006 07/01/2018

CLARK, COWLITZ, KLICKITAT, SKAMANIA and WAHKIAKUM COUNTIES

| | Rates | Fringes |
|------------------------------------|----------|---------|
| Painters: | | |
| HIGHWAY & PARKING LOT STRIPER..... | \$ 35.02 | 12.06 |

PLAS0072-004 06/01/2018

ADAMS, ASOTIN, BENTON, CHELAN, COLUMBIA, DOUGLAS, FERRY, FRANKLIN, GARFIELD, GRANT, KITTITAS, LINCOLN, OKANOGAN, PEND OREILLE, SPOKANE, STEVENS, WALLA WALLA, WHITMAN, AND YAKIMA COUNTIES

| | Rates | Fringes |
|--------------------------------|----------|---------|
| CEMENT MASON/CONCRETE FINISHER | | |
| ZONE 1..... | \$ 29.07 | 14.13 |

Zone Differential (Add to Zone 1 rate): Zone 2 - \$2.00

BASE POINTS: Spokane, Pasco, Lewiston; Wenatchee
Zone 1: 0 - 45 radius miles from the main post office
Zone 2: Over 45 radius miles from the main post office

* PLAS0528-001 06/01/2019

CLALLAM, COWLITZ, GRAYS HARBOR, ISLAND, JEFFERSON, KING,
KITSAP, LEWIS, MASON, PACIFIC, PIERCE, SAN JUAN, SKAGIT,
SNOHOMISH, THURSTON, WAHKIAKUM AND WHATCOM COUNTIES

| | Rates | Fringes |
|--|----------|---------|
| CEMENT MASON | | |
| CEMENT MASON..... | \$ 44.43 | 18.04 |
| COMPOSITION, TROWEL MACHINE, GRINDER, POWER TOOLS, GUNNITE NOZZLE..... | \$ 44.93 | 18.04 |
| TROWELING MACHINE OPERATOR ON COMPOSITION..... | \$ 44.93 | 18.04 |

PLAS0555-002 06/01/2017

CLARK, KLICKITAT AND SKAMANIA COUNTIES

ZONE 1:

| | Rates | Fringes |
|--|----------|---------|
| CEMENT MASON | | |
| CEMENT MASONS DOING BOTH COMPOSITION/POWER MACHINERY AND SUSPENDED/HANGING SCAFFOLD.. | \$ 32.87 | 17.62 |
| CEMENT MASONS ON SUSPENDED, SWINGING AND/OR HANGING SCAFFOLD..... | \$ 32.87 | 17.62 |
| CEMENT MASONS..... | \$ 31.50 | 17.62 |
| COMPOSITION WORKERS AND POWER MACHINERY OPERATORS... | \$ 32.19 | 17.62 |

Zone Differential (Add To Zone 1 Rates):

- Zone 2 - \$0.65
- Zone 3 - 1.15
- Zone 4 - 1.70
- Zone 5 - 3.00

BASE POINTS: BEND, CORVALLIS, EUGENE, MEDFORD, PORTLAND,
SALEM, THE DALLES, VANCOUVER

- ZONE 1: Projects within 30 miles of the respective city hall
- ZONE 2: More than 30 miles but less than 40 miles from the
respective city hall.
- ZONE 3: More than 40 miles but less than 50 miles from the
respective city hall.
- ZONE 4: More than 50 miles but less than 80 miles from the
respective city hall.
- ZONE 5: More than 80 miles from the respective city hall

 TEAM0037-002 06/01/2018

CLARK, COWLITZ, KLICKITAT, PACIFIC (South of a straight line made by extending the north boundary line of Wahkiakum County west to the Pacific Ocean), SKAMANIA, AND WAHKIAKUM COUNTIES

| | Rates | Fringes |
|----------------|----------|---------|
| Truck drivers: | | |
| ZONE 1 | | |
| GROUP 1..... | \$ 28.52 | 14.62 |
| GROUP 2..... | \$ 28.64 | 14.62 |
| GROUP 3..... | \$ 28.78 | 14.62 |
| GROUP 4..... | \$ 29.05 | 14.62 |
| GROUP 5..... | \$ 29.27 | 14.62 |
| GROUP 6..... | \$ 29.45 | 14.62 |
| GROUP 7..... | \$ 29.65 | 14.62 |

Zone Differential (Add to Zone 1 Rates):

Zone 2 - \$0.65

Zone 3 - 1.15

Zone 4 - 1.70

Zone 5 - 2.75

BASE POINTS: ASTORIA, THE DALLES, LONGVIEW AND VANCOUVER

ZONE 1: Projects within 30 miles of the respective city hall.

ZONE 2: More than 30 miles but less than 40 miles from the respective city hall.

ZONE 3: More than 40 miles but less than 50 miles from the respective city hall.

ZONE 4: More than 50 miles but less than 80 miles from the respective city hall.

ZONE 5: More than 80 miles from the respective city hall.

TRUCK DRIVERS CLASSIFICATIONS

GROUP 1: A Frame or Hydra lift truck w/load bearing surface; Articulated Dump Truck; Battery Rebuilders; Bus or Manhaul Driver; Concrete Buggies (power operated); Concrete Pump Truck; Dump Trucks, side, end and bottom dumps, including Semi Trucks and Trains or combinations there of: up to and including 10 cu. yds.; Lift Jitneys, Fork Lifts (all sizes in loading, unloading and transporting material on job site); Loader and/or Leverman on Concrete Dry Batch Plant (manually operated); Pilot Car; Pickup Truck; Solo Flat Bed and misc. Body Trucks, 0-10 tons; Truck Tender; Truck Mechanic Tender; Water Wagons (rated capacity) up to 3,000 gallons; Transit Mix and Wet or Dry Mix - 5 cu. yds. and under; Lubrication Man, Fuel Truck Driver, Tireman, Wash Rack, Steam Cleaner or combinations; Team Driver; Slurry Truck Driver or Leverman; Tireman

GROUP 2: Boom Truck/Hydra-lift or Retracting Crane; Challenger; Dumpsters or similar equipment all sizes; Dump Trucks/Articulated Dumps 6 cu to 10 cu.; Flaherty Spreader Driver or Leverman; Lowbed Equipment, Flat Bed Semi-trailer or doubles transporting equipment or wet or dry materials; Lumber Carrier, Driver-Straddle Carrier (used in loading, unloading and transporting of materials on job site); Oil Distributor Driver or Leverman; Transit mix and wet or dry mix trucks: over 5 cu. yds. and including 7 cu. yds.; Vacuum Trucks; Water truck/Wagons (rated capacity) over 3,000 to 5,000 gallons

GROUP 3: Ammonia Nitrate Distributor Driver; Dump trucks, side, end and bottom dumps, including Semi Trucks and Trains or combinations thereof: over 10 cu. yds. and including 30 cu. yds. includes Articulated Dump Trucks; Self-Propelled Street Sweeper; Transit mix and wet or dry mix truck: over 7 cu yds. and including 11 cu yds.; Truck Mechanic-Welder-Body Repairman; Utility and Clean-up Truck; Water Wagons (rated capacity) over 5,000 to 10,000 gallons

GROUP 4: Asphalt Burner; Dump Trucks, side, end and bottom dumps, including Semi-Trucks and Trains or combinations thereof: over 30 cu. yds. and including 50 cu. yds. includes Articulated Dump Trucks; Fire Guard; Transit Mix and Wet or Dry Mix Trucks, over 11 cu. yds. and including 15 cu. yds.; Water Wagon (rated capacity) over 10,000 gallons to 15,000 gallons

GROUP 5: Composite Crewman; Dump Trucks, side, end and bottom dumps, including Semi Trucks and Trains or combinations thereof: over 50 cu. yds. and including 60 cu. yds. includes Articulated Dump Trucks

GROUP 6: Bulk Cement Spreader w/o Auger; Dry Pre-Batch concrete Mix Trucks; Dump trucks, side, end and bottom dumps, including Semi Trucks and Trains of combinations thereof: over 60 cu. yds. and including 80 cu. yds., and includes Articulated Dump Trucks; Skid Truck

GROUP 7: Dump Trucks, side, end and bottom dumps, including Semi Trucks and Trains or combinations thereof: over 80 cu. yds. and including 100 cu. yds., includes Articulated Dump Trucks; Industrial Lift Truck (mechanical tailgate)

* TEAM0174-001 01/01/2018

CLALLAM, GRAYS HARBOR, ISLAND, JEFFERSON, KING, KITSAP, LEWIS, MASON, PACIFIC (North of a straight line made by extending the north boundary line of Wahkiakum County west to the Pacific Ocean), PIERCE, SAN JUAN, SKAGIT, SNOHOMISH, THURSTON AND WHATCOM COUNTIES

| | Rates | Fringes |
|----------------|----------|---------|
| Truck drivers: | | |
| ZONE A: | | |
| GROUP 1:..... | \$ 35.63 | 18.67 |
| GROUP 2:..... | \$ 34.79 | 18.67 |
| GROUP 3:..... | \$ 31.98 | 18.67 |
| GROUP 4:..... | \$ 27.01 | 18.67 |
| GROUP 5:..... | \$ 35.18 | 18.67 |

ZONE B (25-45 miles from center of listed cities*): Add \$.70 per hour to Zone A rates.

ZONE C (over 45 miles from centr of listed cities*): Add \$1.00 per hour to Zone A rates.

*Zone pay will be calculated from the city center of the following listed cities:

| | | | |
|------------|---------------|------------|-----------|
| BELLINGHAM | CENTRALIA | RAYMOND | OLYMPIA |
| EVERETT | SHELTON | ANACORTES | BELLEVUE |
| SEATTLE | PORT ANGELES | MT. VERNON | KENT |
| TACOMA | PORT TOWNSEND | ABERDEEN | BREMERTON |

TRUCK DRIVERS CLASSIFICATIONS

GROUP 1 - "A-frame or Hydralift" trucks and Boom trucks or similar equipment when "A" frame or "Hydralift" and Boom truck or similar equipment is used; Buggymobile; Bulk Cement Tanker; Dumpsters and similar equipment, Tournorockers, Tournowagon, Tournotrailer, Cat DW series, Terra Cobra, Le Tourneau, Westinghouse, Athye Wagon, Euclid Two and Four-Wheeled power tractor with trailer and similar top-loaded equipment transporting material: Dump Trucks, side, end and bottom dump, including semi-trucks and trains or combinations thereof with 16 yards to 30 yards capacity: Over 30 yards \$.15 per hour additional for each 10 yard increment; Explosive Truck (field mix) and similar equipment; Hyster Operators (handling bulk loose aggregates); Lowbed and Heavy Duty Trailer; Road Oil Distributor Driver; Spreader, Flaherty Transit mix used exclusively in heavy construction; Water Wagon and Tank Truck-3,000 gallons and over capacity

GROUP 2 - Bulllifts, or similar equipment used in loading or unloading trucks, transporting materials on job site; Dumpsters, and similar equipment, Tournorockers, Tournowagon, Turnotrailer, Cat. D.W. Series, Terra Cobra, Le Tourneau, Westinghouse, Athye wagon, Euclid two and four-wheeled power tractor with trailer and similar top-loaded equipment transporting material: Dump trucks, side, end and bottom dump, including semi-trucks and trains or combinations thereof with less than 16 yards capacity; Flatbed (Dual Rear Axle); Grease Truck, Fuel Truck, Greaser, Battery Service Man and/or Tire Service Man; Leverman and loader at bunkers and batch plants; Oil tank transport; Scissor truck; Slurry Truck; Sno-Go and similar equipment; Swampers; Straddler Carrier (Ross, Hyster) and similar equipment; Team Driver; Tractor (small, rubber-tired)(when used within Teamster jurisdiction); Vacuum truck; Water Wagon and Tank trucks-less than 3,000 gallons capacity; Winch Truck; Wrecker, Tow truck and similar equipment

GROUP 3 - Flatbed (single rear axle); Pickup Sweeper; Pickup Truck. (Adjust Group 3 upward by \$2.00 per hour for onsite work only)

GROUP 4 - Escort or Pilot Car

GROUP 5 - Mechanic

HAZMAT PROJECTS

Anyone working on a HAZMAT job, where HAZMAT certification is required, shall be compensated as a premium, in addition to the classification working in as follows:

LEVEL C: +\$.25 per hour - This level uses an air purifying respirator or additional protective clothing.

LEVEL B: +\$.50 per hour - Uses same respirator protection as Level A. Supplied air line is provided in conjunction with a chemical "splash suit."

LEVEL A: +\$.75 per hour - This level utilizes a fully-encapsulated suit with a self-contained breathing apparatus or a supplied air line.

TEAM0690-004 01/01/2019

ADAMS, ASOTIN, BENTON, CHELAN, COLUMBIA, DOUGLAS, FERRY, FRANKLIN, GARFIELD, GRANT KITTITAS, LINCOLN, OKANOGAN, PEND OREILLE, SPOKANE, STEVENS, WALLA WALLA, WHITMAN AND YAKIMA COUNTIES

Rates Fringes

Truck drivers: (AREA 1:
SPOKANE ZONE CENTER: Adams, Chelan, Douglas, Ferry, Grant, Kittitas, Lincoln, Okanogan, Pen Oreille, Spokane, Stevens, and Whitman Counties

AREA 1: LEWISTON ZONE CENTER: Asotin, Columbia, and Garfield Counties

AREA 2: PASCO ZONE CENTER: Benton, Franklin, Walla Walla and Yakima Counties)

AREA 1:

| | | |
|--------------|----------|-------|
| GROUP 1..... | \$ 23.91 | 17.40 |
| GROUP 2..... | \$ 26.18 | 17.40 |
| GROUP 3..... | \$ 26.68 | 17.40 |
| GROUP 4..... | \$ 27.01 | 17.40 |
| GROUP 5..... | \$ 27.12 | 17.40 |
| GROUP 6..... | \$ 27.29 | 17.40 |
| GROUP 7..... | \$ 27.82 | 17.40 |
| GROUP 8..... | \$ 28.18 | 17.40 |

AREA 2:

| | | |
|--------------|----------|-------|
| GROUP 1..... | \$ 26.05 | 17.40 |
| GROUP 2..... | \$ 28.69 | 17.40 |
| GROUP 3..... | \$ 28.80 | 17.40 |
| GROUP 4..... | \$ 29.13 | 17.40 |
| GROUP 5..... | \$ 29.24 | 17.40 |
| GROUP 6..... | \$ 29.24 | 17.40 |
| GROUP 7..... | \$ 29.78 | 17.40 |
| GROUP 8..... | \$ 30.10 | 17.40 |

Zone Differential (Add to Zone 1 rate: Zone 1 + \$2.00)

BASE POINTS: Spokane, Pasco, Lewiston
Zone 1: 0-45 radius miles from the main post office.
Zone 2: Outside 45 radius miles from the main post office

TRUCK DRIVERS CLASSIFICATIONS

GROUP 1: Escort Driver or Pilot Car; Employee Haul; Power Boat Hauling Employees or Material

GROUP 2: Fish Truck; Flat Bed Truck; Fork Lift (3000 lbs. and under); Leverperson (loading trucks at bunkers); Trailer Mounted Hydro Seeder and Mulcher; Seeder & Mulcher; Stationary Fuel Operator; Tractor (small, rubber-tired, pulling trailer or similar equipment)

GROUP 3: Auto Crane (2000 lbs. capacity); Buggy Mobile & Similar; Bulk Cement Tanks & Spreader; Dumptor (6 yds. & under); Flat Bed Truck with Hydraulic System; Fork Lift (3001-16,000 lbs.); Fuel Truck Driver, Steamcleaner & Washer; Power Operated Sweeper; Rubber-tired Tunnel Jumbo; Scissors Truck; Slurry Truck Driver; Straddle Carrier (Ross, Hyster, & similar); Tireperson; Transit Mixers & Truck Hauling Concrete (3 yd. to & including 6 yds.); Trucks, side, end, bottom & articulated end dump (3 yards to and including 6 yds.); Warehouseperson (to include shipping & receiving); Wrecker & Tow Truck

GROUP 4: A-Frame; Burner, Cutter, & Welder; Service Greaser; Trucks, side, end, bottom & articulated end dump (over 6 yards to and including 12 yds.); Truck Mounted Hydro Seeder; Warehouseperson; Water Tank truck (0-8,000 gallons)

GROUP 5: Dumptor (over 6 yds.); Lowboy (50 tons & under); Self-loading Roll Off; Semi-Truck & Trailer; Tractor with Steer Trailer; Transit Mixers and Trucks Hauling Concrete (over 6 yds. to and including 10 yds.); Trucks, side, end, bottom and end dump (over 12 yds. to & including 20 yds.); Truck-Mounted Crane (with load bearing surface either mounted or pulled, up to 14 ton); Vacuum Truck (super sucker, guzzler, etc.)

GROUP 6: Flaherty Spreader Box Driver; Flowboys; Fork Lift (over 16,000 lbs.); Dumps (Semi-end); Mechanic (Field); Semi-end Dumps; Transfer Truck & Trailer; Transit Mixers & Trucks Hauling Concrete (over 10 yds. to & including 20 yds.); Trucks, side, end, bottom and articulated end dump (over 20 yds. to & including 40 yds.); Truck and Pup; Tournarocker, DWs & similar with 2 or more 4 wheel-power tractor with trailer, gallonage or yardage scale, whichever is greater Water Tank Truck (8,001- 14,000 gallons); Lowboy(over 50 tons)

GROUP 7: Oil Distributor Driver; Stringer Truck (cable operated trailer); Transit Mixers & Trucks Hauling Concrete (over 20 yds.); Truck, side, end, bottom end dump (over 40 yds. to & including 100 yds.); Truck Mounted Crane (with load bearing surface either mounted or pulled (16 through 25 tons);

GROUP 8: Prime Movers and Stinger Truck; Trucks, side, end, bottom and articulated end dump (over 100 yds.); Helicopter Pilot Hauling Employees or Materials

Footnote A - Anyone working on a HAZMAT job, where HAZMAT certification is required, shall be compensated as a premium, in addition to the classification working in as follows:

LEVEL C-D: - \$.50 PER HOUR (This is the lowest level of protection. This level may use an air purifying respirator or additional protective clothing.

LEVEL A-B: - \$1.00 PER HOUR (Uses supplied air in conjunction with a chemical splash suit or fully encapsulated suit with a self-contained breathing apparatus.

Employees shall be paid Hazmat pay in increments of four(4) and eight(8) hours.

NOTE:

Trucks Pulling Equipment Trailers: shall receive \$.15/hour over applicable truck rate

WELDERS - Receive rate prescribed for craft performing operation to which welding is incidental.
=====

Note: Executive Order (EO) 13706, Establishing Paid Sick Leave for Federal Contractors applies to all contracts subject to the Davis-Bacon Act for which the contract is awarded (and any solicitation was issued) on or after January 1, 2017. If this contract is covered by the EO, the contractor must provide employees with 1 hour of paid sick leave for every 30 hours they work, up to 56 hours of paid sick leave each year. Employees must be permitted to use paid sick leave for their own illness, injury or other health-related needs, including preventive care; to assist a family member (or person who is like family to the employee) who is ill, injured, or has other health-related needs, including preventive care; or for reasons resulting from, or to assist a family member (or person who is like family to the employee) who is a victim of, domestic violence, sexual assault, or stalking. Additional information on contractor requirements and worker protections under the EO is available at www.dol.gov/whd/govcontracts.

Unlisted classifications needed for work not included within the scope of the classifications listed may be added after award only as provided in the labor standards contract clauses (29CFR 5.5 (a) (1) (ii)).

The body of each wage determination lists the classification and wage rates that have been found to be prevailing for the cited type(s) of construction in the area covered by the wage determination. The classifications are listed in alphabetical order of "identifiers" that indicate whether the particular rate is a union rate (current union negotiated rate for local), a survey rate (weighted average rate) or a union average rate (weighted union average rate).

Union Rate Identifiers

A four letter classification abbreviation identifier enclosed in dotted lines beginning with characters other than "SU" or "UAVG" denotes that the union classification and rate were prevailing for that classification in the survey. Example: PLUM0198-005 07/01/2014. PLUM is an abbreviation identifier of the union which prevailed in the survey for this classification, which in this example would be Plumbers. 0198 indicates the local union number or district council number where applicable, i.e., Plumbers Local 0198. The next number, 005 in the example, is an internal number used in processing the wage determination. 07/01/2014 is the effective date of the most current negotiated rate, which in this example is July 1, 2014.

Union prevailing wage rates are updated to reflect all rate changes in the collective bargaining agreement (CBA) governing this classification and rate.

Survey Rate Identifiers

Classifications listed under the "SU" identifier indicate that no one rate prevailed for this classification in the survey and the published rate is derived by computing a weighted average rate based on all the rates reported in the survey for that classification. As this weighted average rate includes all rates reported in the survey, it may include both union and non-union rates. Example: SULA2012-007 5/13/2014. SU indicates the rates are survey rates based on a weighted average calculation of rates and are not majority rates. LA indicates the State of Louisiana. 2012 is the year of survey on which these classifications and rates are based. The next number, 007 in the example, is an internal number used in producing the wage determination. 5/13/2014 indicates the survey completion date for the classifications and rates under that identifier.

Survey wage rates are not updated and remain in effect until a new survey is conducted.

Union Average Rate Identifiers

Classification(s) listed under the UAVG identifier indicate that no single majority rate prevailed for those classifications; however, 100% of the data reported for the classifications was union data. EXAMPLE: UAVG-OH-0010 08/29/2014. UAVG indicates that the rate is a weighted union average rate. OH indicates the state. The next number, 0010 in the example, is an internal number used in producing the wage determination. 08/29/2014 indicates the survey completion date for the classifications and rates under that identifier.

A UAVG rate will be updated once a year, usually in January of each year, to reflect a weighted average of the current negotiated/CBA rate of the union locals from which the rate is based.

WAGE DETERMINATION APPEALS PROCESS

1.) Has there been an initial decision in the matter? This can be:

- * an existing published wage determination
- * a survey underlying a wage determination
- * a Wage and Hour Division letter setting forth a position on a wage determination matter
- * a conformance (additional classification and rate) ruling

On survey related matters, initial contact, including requests for summaries of surveys, should be with the Wage and Hour Regional Office for the area in which the survey was conducted because those Regional Offices have responsibility for the Davis-Bacon survey program. If the response from this initial contact is not satisfactory, then the process described in 2.) and 3.) should be followed.

With regard to any other matter not yet ripe for the formal process described here, initial contact should be with the Branch of Construction Wage Determinations. Write to:

Branch of Construction Wage Determinations
Wage and Hour Division
U.S. Department of Labor
200 Constitution Avenue, N.W.
Washington, DC 20210

2.) If the answer to the question in 1.) is yes, then an interested party (those affected by the action) can request review and reconsideration from the Wage and Hour Administrator (See 29 CFR Part 1.8 and 29 CFR Part 7). Write to:

Wage and Hour Administrator
U.S. Department of Labor
200 Constitution Avenue, N.W.
Washington, DC 20210

The request should be accompanied by a full statement of the interested party's position and by any information (wage payment data, project description, area practice material, etc.) that the requestor considers relevant to the issue.

3.) If the decision of the Administrator is not favorable, an interested party may appeal directly to the Administrative Review Board (formerly the Wage Appeals Board). Write to:

Administrative Review Board
U.S. Department of Labor
200 Constitution Avenue, N.W.
Washington, DC 20210

4.) All decisions by the Administrative Review Board are final.

=====

END OF GENERAL DECISION"

APPENDIX B

FEDERAL CONTRACT PROVISIONS

REQUIRED CONTRACT PROVISIONS FEDERAL-AID CONSTRUCTION CONTRACTS – FHWA 1273

REQUIRED CONTRACT PROVISIONS FEDERAL-AID CONSTRUCTION CONTRACTS
FHWA-1273 -- Revised May 1, 2012

- I. General
- II. Nondiscrimination
- III. Nonsegregated Facilities
- IV. Davis-Bacon and Related Act Provisions
- V. Contract Work Hours and Safety Standards Act Provisions
- VI. Subletting or Assigning the Contract
- VII. Safety: Accident Prevention
- VIII. False Statements Concerning Highway Projects
- IX. Implementation of Clean Air Act and Federal Water Pollution Control Act
- X. Compliance with Governmentwide Suspension and Debarment Requirements
- XI. Certification Regarding Use of Contract Funds for Lobbying

ATTACHMENTS

A. Employment and Materials Preference for Appalachian Development Highway System or Appalachian Local Access Road Contracts (included in Appalachian contracts only)

I. GENERAL

1. Form FHWA-1273 must be physically incorporated in each construction contract funded under Title 23 (excluding emergency contracts solely intended for debris removal). The contractor (or subcontractor) must insert this form in each subcontract and further require its inclusion in all lower tier subcontracts (excluding purchase orders, rental agreements and other agreements for supplies or services).

The applicable requirements of Form FHWA-1273 are incorporated by reference for work done under any purchase order, rental agreement or agreement for other services. The prime contractor shall be responsible for compliance by any subcontractor, lower-tier subcontractor or service provider.

Form FHWA-1273 must be included in all Federal-aid design-build contracts, in all subcontracts and in lower tier subcontracts (excluding subcontracts for design services, purchase orders, rental agreements and other agreements for supplies or services). The design-builder shall be responsible for compliance by any subcontractor, lower-tier subcontractor or service provider.

Contracting agencies may reference Form FHWA-1273 in bid proposal or request for proposal documents, however, the Form FHWA-1273 must be physically incorporated (not referenced) in all contracts, subcontracts and lower-tier subcontracts (excluding purchase orders, rental agreements and other agreements for supplies or services related to a construction contract).

2. Subject to the applicability criteria noted in the following sections, these contract provisions shall apply to all work performed on the contract by the contractor's own organization and with

the assistance of workers under the contractor's immediate superintendence and to all work performed on the contract by piecework, station work, or by subcontract.

3. A breach of any of the stipulations contained in these Required Contract Provisions may be sufficient grounds for withholding of progress payments, withholding of final payment, termination of the contract, suspension / debarment or any other action determined to be appropriate by the contracting agency and FHWA.

4. Selection of Labor: During the performance of this contract, the contractor shall not use convict labor for any purpose within the limits of a construction project on a Federal-aid highway unless it is labor performed by convicts who are on parole, supervised release, or probation. The term Federal-aid highway does not include roadways functionally classified as local roads or rural minor collectors.

II. NONDISCRIMINATION

The provisions of this section related to 23 CFR Part 230 are applicable to all Federal-aid construction contracts and to all related construction subcontracts of \$10,000 or more. The provisions of 23 CFR Part 230 are not applicable to material supply, engineering, or architectural service contracts.

In addition, the contractor and all subcontractors must comply with the following policies: Executive Order 11246, 41 CFR 60, 29 CFR 1625-1627, Title 23 USC Section 140, the Rehabilitation Act of 1973, as amended (29 USC 794), Title VI of the Civil Rights Act of 1964, as amended, and related regulations including 49 CFR Parts 21, 26 and 27; and 23 CFR Parts 200, 230, and 633.

The contractor and all subcontractors must comply with: the requirements of the Equal Opportunity Clause in 41 CFR 60-1.4(b) and, for all construction contracts exceeding \$10,000, the Standard Federal Equal Employment Opportunity Construction Contract Specifications in 41 CFR 60-4.3.

Note: The U.S. Department of Labor has exclusive authority to determine compliance with Executive Order 11246 and the policies of the Secretary of Labor including 41 CFR 60, and 29 CFR 1625-1627. The contracting agency and the FHWA have the authority and the responsibility to ensure compliance with Title 23 USC Section 140, the Rehabilitation Act of 1973, as amended (29 USC 794), and Title VI of the Civil Rights Act of 1964, as amended, and related regulations including 49 CFR Parts 21, 26 and 27; and 23 CFR Parts 200, 230, and 633.

The following provision is adopted from 23 CFR 230, Appendix A, with appropriate revisions to conform to the U.S. Department of Labor (US DOL) and FHWA requirements.

1. Equal Employment Opportunity: Equal employment opportunity (EEO) requirements not to discriminate and to take affirmative action to assure equal opportunity as set forth under laws, executive orders, rules, regulations (28 CFR 35, 29 CFR 1630, 29 CFR 1625-1627, 41 CFR 60 and 49 CFR 27) and orders of the Secretary of Labor as modified by the provisions prescribed herein, and imposed pursuant to 23 U.S.C. 140 shall constitute the EEO and specific affirmative action standards for the contractor's project activities under this contract. The provisions of the Americans with Disabilities Act of 1990 (42 U.S.C. 12101 et seq.) set forth under 28 CFR 35 and 29 CFR 1630 are incorporated by reference in this contract. In the execution of this

contract, the contractor agrees to comply with the following minimum specific requirement activities of EEO:

a. The contractor will work with the contracting agency and the Federal Government to ensure that it has made every good faith effort to provide equal opportunity with respect to all of its terms and conditions of employment and in their review of activities under the contract.

b. The contractor will accept as its operating policy the following statement:

"It is the policy of this Company to assure that applicants are employed, and that employees are treated during employment, without regard to their race, religion, sex, color, national origin, age or disability. Such action shall include: employment, upgrading, demotion, or transfer; recruitment or recruitment advertising; layoff or termination; rates of pay or other forms of compensation; and selection for training, including apprenticeship, pre-apprenticeship, and/or on-the-job training."

2. EEO Officer: The contractor will designate and make known to the contracting officers an EEO Officer who will have the responsibility for and must be capable of effectively administering and promoting an active EEO program and who must be assigned adequate authority and responsibility to do so.

3. Dissemination of Policy: All members of the contractor's staff who are authorized to hire, supervise, promote, and discharge employees, or who recommend such action, or who are substantially involved in such action, will be made fully cognizant of, and will implement, the contractor's EEO policy and contractual responsibilities to provide EEO in each grade and classification of employment. To ensure that the above agreement will be met, the following actions will be taken as a minimum:

a. Periodic meetings of supervisory and personnel office employees will be conducted before the start of work and then not less often than once every six months, at which time the contractor's EEO policy and its implementation will be reviewed and explained. The meetings will be conducted by the EEO Officer.

b. All new supervisory or personnel office employees will be given a thorough indoctrination by the EEO Officer, covering all major aspects of the contractor's EEO obligations within thirty days following their reporting for duty with the contractor.

c. All personnel who are engaged in direct recruitment for the project will be instructed by the EEO Officer in the contractor's procedures for locating and hiring minorities and women.

d. Notices and posters setting forth the contractor's EEO policy will be placed in areas readily accessible to employees, applicants for employment and potential employees.

e. The contractor's EEO policy and the procedures to implement such policy will be brought to the attention of employees by means of meetings, employee handbooks, or other appropriate means.

4. Recruitment: When advertising for employees, the contractor will include in all advertisements for employees the notation: "An Equal Opportunity Employer." All such advertisements will be placed in publications having a large circulation among minorities and women in the area from which the project work force would normally be derived.

a. The contractor will, unless precluded by a valid bargaining agreement, conduct systematic and direct recruitment through public and private employee referral sources likely to yield qualified minorities and women. To meet this requirement, the contractor will identify sources of potential minority group employees, and establish with such identified sources procedures whereby minority and women applicants may be referred to the contractor for employment consideration.

b. In the event the contractor has a valid bargaining agreement providing for exclusive hiring hall referrals, the contractor is expected to observe the provisions of that agreement to the extent that the system meets the contractor's compliance with EEO contract provisions. Where implementation of such an agreement has the effect of discriminating against minorities or women, or obligates the contractor to do the same, such implementation violates Federal nondiscrimination provisions.

c. The contractor will encourage its present employees to refer minorities and women as applicants for employment. Information and procedures with regard to referring such applicants will be discussed with employees.

5. Personnel Actions: Wages, working conditions, and employee benefits shall be established and administered, and personnel actions of every type, including hiring, upgrading, promotion, transfer, demotion, layoff, and termination, shall be taken without regard to race, color, religion, sex, national origin, age or disability. The following procedures shall be followed:

a. The contractor will conduct periodic inspections of project sites to insure that working conditions and employee facilities do not indicate discriminatory treatment of project site personnel.

b. The contractor will periodically evaluate the spread of wages paid within each classification to determine any evidence of discriminatory wage practices.

c. The contractor will periodically review selected personnel actions in depth to determine whether there is evidence of discrimination. Where evidence is found, the contractor will promptly take corrective action. If the review indicates that the discrimination may extend beyond the actions reviewed, such corrective action shall include all affected persons.

d. The contractor will promptly investigate all complaints of alleged discrimination made to the contractor in connection with its obligations under this contract, will attempt to resolve such complaints, and will take appropriate corrective action within a reasonable time. If the investigation indicates that the discrimination may affect persons other than the complainant, such corrective action shall include such other persons. Upon completion of each investigation, the contractor will inform every complainant of all of their avenues of appeal.

6. Training and Promotion:

a. The contractor will assist in locating, qualifying, and increasing the skills of minorities and women who are applicants for employment or current employees. Such efforts should be aimed at developing full journey level status employees in the type of trade or job classification involved.

b. Consistent with the contractor's work force requirements and as permissible under Federal and State regulations, the contractor shall make full use of training programs, i.e., apprenticeship, and on-the-job training programs for the geographical area of contract performance. In the event a special provision for training is provided under this contract, this subparagraph will be superseded as indicated in the special provision. The contracting agency may reserve training positions for persons who receive welfare assistance in accordance with 23 U.S.C. 140(a).

c. The contractor will advise employees and applicants for employment of available training programs and entrance requirements for each.

d. The contractor will periodically review the training and promotion potential of employees who are minorities and women and will encourage eligible employees to apply for such training and promotion.

7. Unions: If the contractor relies in whole or in part upon unions as a source of employees, the contractor will use good faith efforts to obtain the cooperation of such unions to increase opportunities for minorities and women. Actions by the contractor, either directly or through a contractor's association acting as agent, will include the procedures set forth below:

a. The contractor will use good faith efforts to develop, in cooperation with the unions, joint training programs aimed toward qualifying more minorities and women for membership in the unions and increasing the skills of minorities and women so that they may qualify for higher paying employment.

b. The contractor will use good faith efforts to incorporate an EEO clause into each union agreement to the end that such union will be contractually bound to refer applicants without regard to their race, color, religion, sex, national origin, age or disability.

c. The contractor is to obtain information as to the referral practices and policies of the labor union except that to the extent such information is within the exclusive possession of the labor union and such labor union refuses to furnish such information to the contractor, the contractor shall so certify to the contracting agency and shall set forth what efforts have been made to obtain such information.

d. In the event the union is unable to provide the contractor with a reasonable flow of referrals within the time limit set forth in the collective bargaining agreement, the contractor will, through independent recruitment efforts, fill the employment vacancies without regard to race, color, religion, sex, national origin, age or disability; making full efforts to obtain qualified and/or qualifiable minorities and women. The failure of a union to provide sufficient referrals (even though it is obligated to provide exclusive referrals under the terms of a collective bargaining agreement) does not relieve the contractor from the requirements of this paragraph. In the event the union referral practice prevents the contractor from meeting the obligations pursuant to Executive Order 11246, as amended, and these special provisions, such contractor shall immediately notify the contracting agency.

8. Reasonable Accommodation for Applicants / Employees with Disabilities: The contractor must be familiar with the requirements for and comply with the Americans with Disabilities Act and all rules and regulations established there under. Employers must provide reasonable accommodation in all employment activities unless to do so would cause an undue hardship.

9. Selection of Subcontractors, Procurement of Materials and Leasing of Equipment: The contractor shall not discriminate on the grounds of race, color, religion, sex, national origin, age or disability in the selection and retention of subcontractors, including procurement of materials and leases of equipment. The contractor shall take all necessary and reasonable steps to ensure nondiscrimination in the administration of this contract.

a. The contractor shall notify all potential subcontractors and suppliers and lessors of their EEO obligations under this contract.

b. The contractor will use good faith efforts to ensure subcontractor compliance with their EEO obligations.

10. Assurance Required by 49 CFR 26.13(b):

a. The requirements of 49 CFR Part 26 and the State DOT's U.S. DOT-approved DBE program are incorporated by reference.

b. The contractor or subcontractor shall not discriminate on the basis of race, color, national origin, or sex in the performance of this contract. The contractor shall carry out applicable requirements of 49 CFR Part 26 in the award and administration of DOT-assisted contracts. Failure by the contractor to carry out these requirements is a material breach of this contract, which may result in the termination of this contract or such other remedy as the contracting agency deems appropriate.

11. Records and Reports: The contractor shall keep such records as necessary to document compliance with the EEO requirements. Such records shall be retained for a period of three years following the date of the final payment to the contractor for all contract work and shall be available at reasonable times and places for inspection by authorized representatives of the contracting agency and the FHWA.

a. The records kept by the contractor shall document the following:

(1) The number and work hours of minority and non-minority group members and women employed in each work classification on the project;

(2) The progress and efforts being made in cooperation with unions, when applicable, to increase employment opportunities for minorities and women; and

(3) The progress and efforts being made in locating, hiring, training, qualifying, and upgrading minorities and women;

b. The contractors and subcontractors will submit an annual report to the contracting agency each July for the duration of the project, indicating the number of minority, women, and non-minority group employees currently engaged in each work classification required by the contract work. This information is to be reported on [Form FHWA-1391](#). The staffing data should represent the project work force on board in all or any part of the last payroll period preceding the end of July. If on-the-job training is being required by special provision, the contractor will be required to collect and report training data. The employment data should reflect the work force on board during all or any part of the last payroll period preceding the end of July.

III. NONSEGREGATED FACILITIES

This provision is applicable to all Federal-aid construction contracts and to all related construction subcontracts of \$10,000 or more.

The contractor must ensure that facilities provided for employees are provided in such a manner that segregation on the basis of race, color, religion, sex, or national origin cannot result. The contractor may neither require such segregated use by written or oral policies nor tolerate such use by employee custom. The contractor's obligation extends further to ensure that its employees are not assigned to perform their services at any location, under the contractor's control, where the facilities are segregated. The term "facilities" includes waiting rooms, work areas, restaurants and other eating areas, time clocks, restrooms, washrooms, locker rooms, and other storage or dressing areas, parking lots, drinking fountains, recreation or entertainment areas, transportation, and housing provided for employees. The contractor shall provide separate or single-user restrooms and necessary dressing or sleeping areas to assure privacy between sexes.

IV. DAVIS-BACON AND RELATED ACT PROVISIONS

This section is applicable to all Federal-aid construction projects exceeding \$2,000 and to all related subcontracts and lower-tier subcontracts (regardless of subcontract size). The requirements apply to all projects located within the right-of-way of a roadway that is functionally classified as Federal-aid highway. This excludes roadways functionally classified as local roads or rural minor collectors, which are exempt. Contracting agencies may elect to apply these requirements to other projects.

The following provisions are from the U.S. Department of Labor regulations in 29 CFR 5.5 "Contract provisions and related matters" with minor revisions to conform to the FHWA-1273 format and FHWA program requirements.

1. Minimum wages

a. All laborers and mechanics employed or working upon the site of the work, will be paid unconditionally and not less often than once a week, and without subsequent deduction or rebate on any account (except such payroll deductions as are permitted by regulations issued by the Secretary of Labor under the Copeland Act (29 CFR part 3)), the full amount of wages and bona fide fringe benefits (or cash equivalents thereof) due at time of payment computed at rates not less than those contained in the wage determination of the Secretary of Labor which is attached hereto and made a part hereof, regardless of any contractual relationship which may be alleged to exist between the contractor and such laborers and mechanics.

Contributions made or costs reasonably anticipated for bona fide fringe benefits under section 1(b)(2) of the Davis-Bacon Act on behalf of laborers or mechanics are considered wages paid to such laborers or mechanics, subject to the provisions of paragraph 1.d. of this section; also, regular contributions made or costs incurred for more than a weekly period (but not less often than quarterly) under plans, funds, or programs which cover the particular weekly period, are deemed to be constructively made or incurred during such weekly period. Such laborers and

mechanics shall be paid the appropriate wage rate and fringe benefits on the wage determination for the classification of work actually performed, without regard to skill, except as provided in 29 CFR 5.5(a)(4). Laborers or mechanics performing work in more than one classification may be compensated at the rate specified for each classification for the time actually worked therein: Provided, That the employer's payroll records accurately set forth the time spent in each classification in which work is performed. The wage determination (including any additional classification and wage rates conformed under paragraph 1.b. of this section) and the Davis-Bacon poster (WH-1321) shall be posted at all times by the contractor and its subcontractors at the site of the work in a prominent and accessible place where it can be easily seen by the workers.

b. (1) The contracting officer shall require that any class of laborers or mechanics, including helpers, which is not listed in the wage determination and which is to be employed under the contract shall be classified in conformance with the wage determination. The contracting officer shall approve an additional classification and wage rate and fringe benefits therefore only when the following criteria have been met:

(i) The work to be performed by the classification requested is not performed by a classification in the wage determination; and

(ii) The classification is utilized in the area by the construction industry; and

(iii) The proposed wage rate, including any bona fide fringe benefits, bears a reasonable relationship to the wage rates contained in the wage determination.

(2) If the contractor and the laborers and mechanics to be employed in the classification (if known), or their representatives, and the contracting officer agree on the classification and wage rate (including the amount designated for fringe benefits where appropriate), a report of the action taken shall be sent by the contracting officer to the Administrator of the Wage and Hour Division, Employment Standards Administration, U.S. Department of Labor, Washington, DC 20210. The Administrator, or an authorized representative, will approve, modify, or disapprove every additional classification action within 30 days of receipt and so advise the contracting officer or will notify the contracting officer within the 30-day period that additional time is necessary.

(3) In the event the contractor, the laborers or mechanics to be employed in the classification or their representatives, and the contracting officer do not agree on the proposed classification and wage rate (including the amount designated for fringe benefits, where appropriate), the contracting officer shall refer the questions, including the views of all interested parties and the recommendation of the contracting officer, to the Wage and Hour Administrator for determination. The Wage and Hour Administrator, or an authorized representative, will issue a determination within 30 days of receipt and so advise the contracting officer or will notify the contracting officer within the 30-day period that additional time is necessary.

(4) The wage rate (including fringe benefits where appropriate) determined pursuant to paragraphs 1.b.(2) or 1.b.(3) of this section, shall be paid to all workers performing work in the classification under this contract from the first day on which work is performed in the classification.

c. Whenever the minimum wage rate prescribed in the contract for a class of laborers or mechanics includes a fringe benefit which is not expressed as an hourly rate, the contractor shall either pay the benefit as stated in the wage determination or shall pay another bona fide fringe benefit or an hourly cash equivalent thereof.

d. If the contractor does not make payments to a trustee or other third person, the contractor may consider as part of the wages of any laborer or mechanic the amount of any costs reasonably anticipated in providing bona fide fringe benefits under a plan or program, Provided, That the Secretary of Labor has found, upon the written request of the contractor, that the applicable standards of the Davis-Bacon Act have been met. The Secretary of Labor may require the contractor to set aside in a separate account assets for the meeting of obligations under the plan or program.

2. Withholding

The contracting agency shall upon its own action or upon written request of an authorized representative of the Department of Labor, withhold or cause to be withheld from the contractor under this contract, or any other Federal contract with the same prime contractor, or any other federally-assisted contract subject to Davis-Bacon prevailing wage requirements, which is held by the same prime contractor, so much of the accrued payments or advances as may be considered necessary to pay laborers and mechanics, including apprentices, trainees, and helpers, employed by the contractor or any subcontractor the full amount of wages required by the contract. In the event of failure to pay any laborer or mechanic, including any apprentice, trainee, or helper, employed or working on the site of the work, all or part of the wages required by the contract, the contracting agency may, after written notice to the contractor, take such action as may be necessary to cause the suspension of any further payment, advance, or guarantee of funds until such violations have ceased.

3. Payrolls and basic records

a. Payrolls and basic records relating thereto shall be maintained by the contractor during the course of the work and preserved for a period of three years thereafter for all laborers and mechanics working at the site of the work. Such records shall contain the name, address, and social security number of each such worker, his or her correct classification, hourly rates of wages paid (including rates of contributions or costs anticipated for bona fide fringe benefits or cash equivalents thereof of the types described in section 1(b)(2)(B) of the Davis-Bacon Act), daily and weekly number of hours worked, deductions made and actual wages paid. Whenever the Secretary of Labor has found under 29 CFR 5.5(a)(1)(iv) that the wages of any laborer or mechanic include the amount of any costs reasonably anticipated in providing benefits under a plan or program described in section 1(b)(2)(B) of the Davis-Bacon Act, the contractor shall maintain records which show that the commitment to provide such benefits is enforceable, that the plan or program is financially responsible, and that the plan or program has been communicated in writing to the laborers or mechanics affected, and records which show the costs anticipated or the actual cost incurred in providing such benefits. Contractors employing apprentices or trainees under approved programs shall maintain written evidence of the registration of apprenticeship programs and certification of trainee programs, the registration of the apprentices and trainees, and the ratios and wage rates prescribed in the applicable programs.

b. (1) The contractor shall submit weekly for each week in which any contract work is performed a copy of all payrolls to the contracting agency. The payrolls submitted shall set out accurately and completely all of the information required to be maintained under 29 CFR 5.5(a)(3)(i), except that full social security numbers and home addresses shall not be included on weekly transmittals. Instead the payrolls shall only need to include an individually identifying number for each employee (e.g. , the last four digits of the employee's social security number). The required weekly payroll information may be submitted in any form desired. Optional Form WH-347 is available for this purpose from the Wage and Hour Division Web site at <http://www.dol.gov/esa/whd/forms/wh347instr.htm> or its successor site. The prime contractor is responsible for the submission of copies of payrolls by all subcontractors. Contractors and subcontractors shall maintain the full social security number and current address of each covered worker, and shall provide them upon request to the contracting agency for transmission to the State DOT, the FHWA or the Wage and Hour Division of the Department of Labor for purposes of an investigation or audit of compliance with prevailing wage requirements. It is not a violation of this section for a prime contractor to require a subcontractor to provide addresses and social security numbers to the prime contractor for its own records, without weekly submission to the contracting agency..

(2) Each payroll submitted shall be accompanied by a "Statement of Compliance," signed by the contractor or subcontractor or his or her agent who pays or supervises the payment of the persons employed under the contract and shall certify the following:

(i) That the payroll for the payroll period contains the information required to be provided under §5.5 (a)(3)(ii) of Regulations, 29 CFR part 5, the appropriate information is being maintained under §5.5 (a)(3)(i) of Regulations, 29 CFR part 5, and that such information is correct and complete;

(ii) That each laborer or mechanic (including each helper, apprentice, and trainee) employed on the contract during the payroll period has been paid the full weekly wages earned, without rebate, either directly or indirectly, and that no deductions have been made either directly or indirectly from the full wages earned, other than permissible deductions as set forth in Regulations, 29 CFR part 3;

(iii) That each laborer or mechanic has been paid not less than the applicable wage rates and fringe benefits or cash equivalents for the classification of work performed, as specified in the applicable wage determination incorporated into the contract.

(3) The weekly submission of a properly executed certification set forth on the reverse side of Optional Form WH-347 shall satisfy the requirement for submission of the "Statement of Compliance" required by paragraph 3.b.(2) of this section.

(4) The falsification of any of the above certifications may subject the contractor or subcontractor to civil or criminal prosecution under section 1001 of title 18 and section 231 of title 31 of the United States Code.

c. The contractor or subcontractor shall make the records required under paragraph 3.a. of this section available for inspection, copying, or transcription by authorized representatives of the contracting agency, the State DOT, the FHWA, or the Department of Labor, and shall permit such representatives to interview employees during working hours on the job. If the contractor or subcontractor fails to submit the required records or to make them available, the FHWA may,

after written notice to the contractor, the contracting agency or the State DOT, take such action as may be necessary to cause the suspension of any further payment, advance, or guarantee of funds. Furthermore, failure to submit the required records upon request or to make such records available may be grounds for debarment action pursuant to 29 CFR 5.12.

4. Apprentices and trainees

a. Apprentices (programs of the USDOL).

Apprentices will be permitted to work at less than the predetermined rate for the work they performed when they are employed pursuant to and individually registered in a bona fide apprenticeship program registered with the U.S. Department of Labor, Employment and Training Administration, Office of Apprenticeship Training, Employer and Labor Services, or with a State Apprenticeship Agency recognized by the Office, or if a person is employed in his or her first 90 days of probationary employment as an apprentice in such an apprenticeship program, who is not individually registered in the program, but who has been certified by the Office of Apprenticeship Training, Employer and Labor Services or a State Apprenticeship Agency (where appropriate) to be eligible for probationary employment as an apprentice.

The allowable ratio of apprentices to journeymen on the job site in any craft classification shall not be greater than the ratio permitted to the contractor as to the entire work force under the registered program. Any worker listed on a payroll at an apprentice wage rate, who is not registered or otherwise employed as stated above, shall be paid not less than the applicable wage rate on the wage determination for the classification of work actually performed. In addition, any apprentice performing work on the job site in excess of the ratio permitted under the registered program shall be paid not less than the applicable wage rate on the wage determination for the work actually performed. Where a contractor is performing construction on a project in a locality other than that in which its program is registered, the ratios and wage rates (expressed in percentages of the journeyman's hourly rate) specified in the contractor's or subcontractor's registered program shall be observed.

Every apprentice must be paid at not less than the rate specified in the registered program for the apprentice's level of progress, expressed as a percentage of the journeymen hourly rate specified in the applicable wage determination. Apprentices shall be paid fringe benefits in accordance with the provisions of the apprenticeship program. If the apprenticeship program does not specify fringe benefits, apprentices must be paid the full amount of fringe benefits listed on the wage determination for the applicable classification. If the Administrator determines that a different practice prevails for the applicable apprentice classification, fringes shall be paid in accordance with that determination.

In the event the Office of Apprenticeship Training, Employer and Labor Services, or a State Apprenticeship Agency recognized by the Office, withdraws approval of an apprenticeship program, the contractor will no longer be permitted to utilize apprentices at less than the applicable predetermined rate for the work performed until an acceptable program is approved.

b. Trainees (programs of the USDOL).

Except as provided in 29 CFR 5.16, trainees will not be permitted to work at less than the predetermined rate for the work performed unless they are employed pursuant to and

individually registered in a program which has received prior approval, evidenced by formal certification by the U.S. Department of Labor, Employment and Training Administration.

The ratio of trainees to journeymen on the job site shall not be greater than permitted under the plan approved by the Employment and Training Administration.

Every trainee must be paid at not less than the rate specified in the approved program for the trainee's level of progress, expressed as a percentage of the journeyman hourly rate specified in the applicable wage determination. Trainees shall be paid fringe benefits in accordance with the provisions of the trainee program. If the trainee program does not mention fringe benefits, trainees shall be paid the full amount of fringe benefits listed on the wage determination unless the Administrator of the Wage and Hour Division determines that there is an apprenticeship program associated with the corresponding journeyman wage rate on the wage determination which provides for less than full fringe benefits for apprentices. Any employee listed on the payroll at a trainee rate who is not registered and participating in a training plan approved by the Employment and Training Administration shall be paid not less than the applicable wage rate on the wage determination for the classification of work actually performed. In addition, any trainee performing work on the job site in excess of the ratio permitted under the registered program shall be paid not less than the applicable wage rate on the wage determination for the work actually performed.

In the event the Employment and Training Administration withdraws approval of a training program, the contractor will no longer be permitted to utilize trainees at less than the applicable predetermined rate for the work performed until an acceptable program is approved.

c. Equal employment opportunity. The utilization of apprentices, trainees and journeymen under this part shall be in conformity with the equal employment opportunity requirements of Executive Order 11246, as amended, and 29 CFR part 30.

d. Apprentices and Trainees (programs of the U.S. DOT).

Apprentices and trainees working under apprenticeship and skill training programs which have been certified by the Secretary of Transportation as promoting EEO in connection with Federal-aid highway construction programs are not subject to the requirements of paragraph 4 of this Section IV. The straight time hourly wage rates for apprentices and trainees under such programs will be established by the particular programs. The ratio of apprentices and trainees to journeymen shall not be greater than permitted by the terms of the particular program.

5. Compliance with Copeland Act requirements. The contractor shall comply with the requirements of 29 CFR part 3, which are incorporated by reference in this contract.

6. Subcontracts. The contractor or subcontractor shall insert Form FHWA-1273 in any subcontracts and also require the subcontractors to include Form FHWA-1273 in any lower tier subcontracts. The prime contractor shall be responsible for the compliance by any subcontractor or lower tier subcontractor with all the contract clauses in 29 CFR 5.5.

7. Contract termination: debarment. A breach of the contract clauses in 29 CFR 5.5 may be grounds for termination of the contract, and for debarment as a contractor and a subcontractor as provided in 29 CFR 5.12.

8. Compliance with Davis-Bacon and Related Act requirements. All rulings and interpretations of the Davis-Bacon and Related Acts contained in 29 CFR parts 1, 3, and 5 are herein incorporated by reference in this contract.

9. Disputes concerning labor standards. Disputes arising out of the labor standards provisions of this contract shall not be subject to the general disputes clause of this contract. Such disputes shall be resolved in accordance with the procedures of the Department of Labor set forth in 29 CFR parts 5, 6, and 7. Disputes within the meaning of this clause include disputes between the contractor (or any of its subcontractors) and the contracting agency, the U.S. Department of Labor, or the employees or their representatives.

10. Certification of eligibility.

a. By entering into this contract, the contractor certifies that neither it (nor he or she) nor any person or firm who has an interest in the contractor's firm is a person or firm ineligible to be awarded Government contracts by virtue of section 3(a) of the Davis-Bacon Act or 29 CFR 5.12(a)(1).

b. No part of this contract shall be subcontracted to any person or firm ineligible for award of a Government contract by virtue of section 3(a) of the Davis-Bacon Act or 29 CFR 5.12(a)(1).

c. The penalty for making false statements is prescribed in the U.S. Criminal Code, 18 U.S.C. 1001.

V. CONTRACT WORK HOURS AND SAFETY STANDARDS ACT

The following clauses apply to any Federal-aid construction contract in an amount in excess of \$100,000 and subject to the overtime provisions of the Contract Work Hours and Safety Standards Act. These clauses shall be inserted in addition to the clauses required by 29 CFR 5.5(a) or 29 CFR 4.6. As used in this paragraph, the terms laborers and mechanics include watchmen and guards.

1. Overtime requirements. No contractor or subcontractor contracting for any part of the contract work which may require or involve the employment of laborers or mechanics shall require or permit any such laborer or mechanic in any workweek in which he or she is employed on such work to work in excess of forty hours in such workweek unless such laborer or mechanic receives compensation at a rate not less than one and one-half times the basic rate of pay for all hours worked in excess of forty hours in such workweek.

2. Violation; liability for unpaid wages; liquidated damages. In the event of any violation of the clause set forth in paragraph (1.) of this section, the contractor and any subcontractor responsible therefor shall be liable for the unpaid wages. In addition, such contractor and subcontractor shall be liable to the United States (in the case of work done under contract for the District of Columbia or a territory, to such District or to such territory), for liquidated damages. Such liquidated damages shall be computed with respect to each individual laborer or mechanic, including watchmen and guards, employed in violation of the clause set forth in paragraph (1.) of this section, in the sum of \$10 for each calendar day on which such individual

was required or permitted to work in excess of the standard workweek of forty hours without payment of the overtime wages required by the clause set forth in paragraph (1.) of this section.

3. Withholding for unpaid wages and liquidated damages. The FHWA or the contracting agency shall upon its own action or upon written request of an authorized representative of the Department of Labor withhold or cause to be withheld, from any moneys payable on account of work performed by the contractor or subcontractor under any such contract or any other Federal contract with the same prime contractor, or any other federally-assisted contract subject to the Contract Work Hours and Safety Standards Act, which is held by the same prime contractor, such sums as may be determined to be necessary to satisfy any liabilities of such contractor or subcontractor for unpaid wages and liquidated damages as provided in the clause set forth in paragraph (2.) of this section.

4. Subcontracts. The contractor or subcontractor shall insert in any subcontracts the clauses set forth in paragraph (1.) through (4.) of this section and also a clause requiring the subcontractors to include these clauses in any lower tier subcontracts. The prime contractor shall be responsible for compliance by any subcontractor or lower tier subcontractor with the clauses set forth in paragraphs (1.) through (4.) of this section.

VI. SUBLETTING OR ASSIGNING THE CONTRACT

This provision is applicable to all Federal-aid construction contracts on the National Highway System.

1. The contractor shall perform with its own organization contract work amounting to not less than 30 percent (or a greater percentage if specified elsewhere in the contract) of the total original contract price, excluding any specialty items designated by the contracting agency. Specialty items may be performed by subcontract and the amount of any such specialty items performed may be deducted from the total original contract price before computing the amount of work required to be performed by the contractor's own organization (23 CFR 635.116).

a. The term "perform work with its own organization" refers to workers employed or leased by the prime contractor, and equipment owned or rented by the prime contractor, with or without operators. Such term does not include employees or equipment of a subcontractor or lower tier subcontractor, agents of the prime contractor, or any other assignees. The term may include payments for the costs of hiring leased employees from an employee leasing firm meeting all relevant Federal and State regulatory requirements. Leased employees may only be included in this term if the prime contractor meets all of the following conditions:

(1) the prime contractor maintains control over the supervision of the day-to-day activities of the leased employees;

(2) the prime contractor remains responsible for the quality of the work of the leased employees;

(3) the prime contractor retains all power to accept or exclude individual employees from work on the project; and

(4) the prime contractor remains ultimately responsible for the payment of predetermined minimum wages, the submission of payrolls, statements of compliance and all other Federal regulatory requirements.

b. "Specialty Items" shall be construed to be limited to work that requires highly specialized knowledge, abilities, or equipment not ordinarily available in the type of contracting organizations qualified and expected to bid or propose on the contract as a whole and in general are to be limited to minor components of the overall contract.

2. The contract amount upon which the requirements set forth in paragraph (1) of Section VI is computed includes the cost of material and manufactured products which are to be purchased or produced by the contractor under the contract provisions.

3. The contractor shall furnish (a) a competent superintendent or supervisor who is employed by the firm, has full authority to direct performance of the work in accordance with the contract requirements, and is in charge of all construction operations (regardless of who performs the work) and (b) such other of its own organizational resources (supervision, management, and engineering services) as the contracting officer determines is necessary to assure the performance of the contract.

4. No portion of the contract shall be sublet, assigned or otherwise disposed of except with the written consent of the contracting officer, or authorized representative, and such consent when given shall not be construed to relieve the contractor of any responsibility for the fulfillment of the contract. Written consent will be given only after the contracting agency has assured that each subcontract is evidenced in writing and that it contains all pertinent provisions and requirements of the prime contract.

5. The 30% self-performance requirement of paragraph (1) is not applicable to design-build contracts; however, contracting agencies may establish their own self-performance requirements.

VII. SAFETY: ACCIDENT PREVENTION

This provision is applicable to all Federal-aid construction contracts and to all related subcontracts.

1. In the performance of this contract the contractor shall comply with all applicable Federal, State, and local laws governing safety, health, and sanitation (23 CFR 635). The contractor shall provide all safeguards, safety devices and protective equipment and take any other needed actions as it determines, or as the contracting officer may determine, to be reasonably necessary to protect the life and health of employees on the job and the safety of the public and to protect property in connection with the performance of the work covered by the contract.

2. It is a condition of this contract, and shall be made a condition of each subcontract, which the contractor enters into pursuant to this contract, that the contractor and any subcontractor shall not permit any employee, in performance of the contract, to work in surroundings or under conditions which are unsanitary, hazardous or dangerous to his/her health or safety, as determined under construction safety and health standards (29 CFR 1926) promulgated by the Secretary of Labor, in accordance with Section 107 of the Contract Work Hours and Safety Standards Act (40 U.S.C. 3704).

3. Pursuant to 29 CFR 1926.3, it is a condition of this contract that the Secretary of Labor or authorized representative thereof, shall have right of entry to any site of contract performance to inspect or investigate the matter of compliance with the construction safety and health standards and to carry out the duties of the Secretary under Section 107 of the Contract Work Hours and Safety Standards Act (40 U.S.C.3704).

VIII. FALSE STATEMENTS CONCERNING HIGHWAY PROJECTS

This provision is applicable to all Federal-aid construction contracts and to all related subcontracts.

In order to assure high quality and durable construction in conformity with approved plans and specifications and a high degree of reliability on statements and representations made by engineers, contractors, suppliers, and workers on Federal-aid highway projects, it is essential that all persons concerned with the project perform their functions as carefully, thoroughly, and honestly as possible. Willful falsification, distortion, or misrepresentation with respect to any facts related to the project is a violation of Federal law. To prevent any misunderstanding regarding the seriousness of these and similar acts, Form FHWA-1022 shall be posted on each Federal-aid highway project (23 CFR 635) in one or more places where it is readily available to all persons concerned with the project:

18 U.S.C. 1020 reads as follows:

"Whoever, being an officer, agent, or employee of the United States, or of any State or Territory, or whoever, whether a person, association, firm, or corporation, knowingly makes any false statement, false representation, or false report as to the character, quality, quantity, or cost of the material used or to be used, or the quantity or quality of the work performed or to be performed, or the cost thereof in connection with the submission of plans, maps, specifications, contracts, or costs of construction on any highway or related project submitted for approval to the Secretary of Transportation; or

Whoever knowingly makes any false statement, false representation, false report or false claim with respect to the character, quality, quantity, or cost of any work performed or to be performed, or materials furnished or to be furnished, in connection with the construction of any highway or related project approved by the Secretary of Transportation; or

Whoever knowingly makes any false statement or false representation as to material fact in any statement, certificate, or report submitted pursuant to provisions of the Federal-aid Roads Act approved July 1, 1916, (39 Stat. 355), as amended and supplemented;

Shall be fined under this title or imprisoned not more than 5 years or both."

IX. IMPLEMENTATION OF CLEAN AIR ACT AND FEDERAL WATER POLLUTION CONTROL ACT

This provision is applicable to all Federal-aid construction contracts and to all related subcontracts.

By submission of this bid/proposal or the execution of this contract, or subcontract, as appropriate, the bidder, proposer, Federal-aid construction contractor, or subcontractor, as appropriate, will be deemed to have stipulated as follows:

1. That any person who is or will be utilized in the performance of this contract is not prohibited from receiving an award due to a violation of Section 508 of the Clean Water Act or Section 306 of the Clean Air Act.
2. That the contractor agrees to include or cause to be included the requirements of paragraph (1) of this Section X in every subcontract, and further agrees to take such action as the contracting agency may direct as a means of enforcing such requirements.

X. CERTIFICATION REGARDING DEBARMENT, SUSPENSION, INELIGIBILITY AND VOLUNTARY EXCLUSION

This provision is applicable to all Federal-aid construction contracts, design-build contracts, subcontracts, lower-tier subcontracts, purchase orders, lease agreements, consultant contracts or any other covered transaction requiring FHWA approval or that is estimated to cost \$25,000 or more – as defined in 2 CFR Parts 180 and 1200.

1. Instructions for Certification – First Tier Participants:

a. By signing and submitting this proposal, the prospective first tier participant is providing the certification set out below.

b. The inability of a person to provide the certification set out below will not necessarily result in denial of participation in this covered transaction. The prospective first tier participant shall submit an explanation of why it cannot provide the certification set out below. The certification or explanation will be considered in connection with the department or agency's determination whether to enter into this transaction. However, failure of the prospective first tier participant to furnish a certification or an explanation shall disqualify such a person from participation in this transaction.

c. The certification in this clause is a material representation of fact upon which reliance was placed when the contracting agency determined to enter into this transaction. If it is later determined that the prospective participant knowingly rendered an erroneous certification, in addition to other remedies available to the Federal Government, the contracting agency may terminate this transaction for cause of default.

d. The prospective first tier participant shall provide immediate written notice to the contracting agency to whom this proposal is submitted if any time the prospective first tier participant learns that its certification was erroneous when submitted or has become erroneous by reason of changed circumstances.

e. The terms "covered transaction," "debarred," "suspended," "ineligible," "participant," "person," "principal," and "voluntarily excluded," as used in this clause, are defined in 2 CFR Parts 180 and 1200. "First Tier Covered Transactions" refers to any covered transaction between a grantee or subgrantee of Federal funds and a participant (such as the prime or

general contract). "Lower Tier Covered Transactions" refers to any covered transaction under a First Tier Covered Transaction (such as subcontracts). "First Tier Participant" refers to the participant who has entered into a covered transaction with a grantee or subgrantee of Federal funds (such as the prime or general contractor). "Lower Tier Participant" refers any participant who has entered into a covered transaction with a First Tier Participant or other Lower Tier Participants (such as subcontractors and suppliers).

f. The prospective first tier participant agrees by submitting this proposal that, should the proposed covered transaction be entered into, it shall not knowingly enter into any lower tier covered transaction with a person who is debarred, suspended, declared ineligible, or voluntarily excluded from participation in this covered transaction, unless authorized by the department or agency entering into this transaction.

g. The prospective first tier participant further agrees by submitting this proposal that it will include the clause titled "Certification Regarding Debarment, Suspension, Ineligibility and Voluntary Exclusion-Lower Tier Covered Transactions," provided by the department or contracting agency, entering into this covered transaction, without modification, in all lower tier covered transactions and in all solicitations for lower tier covered transactions exceeding the \$25,000 threshold.

h. A participant in a covered transaction may rely upon a certification of a prospective participant in a lower tier covered transaction that is not debarred, suspended, ineligible, or voluntarily excluded from the covered transaction, unless it knows that the certification is erroneous. A participant is responsible for ensuring that its principals are not suspended, debarred, or otherwise ineligible to participate in covered transactions. To verify the eligibility of its principals, as well as the eligibility of any lower tier prospective participants, each participant may, but is not required to, check the Excluded Parties List System website (<https://www.epls.gov/>), which is compiled by the General Services Administration.

i. Nothing contained in the foregoing shall be construed to require the establishment of a system of records in order to render in good faith the certification required by this clause. The knowledge and information of the prospective participant is not required to exceed that which is normally possessed by a prudent person in the ordinary course of business dealings.

j. Except for transactions authorized under paragraph (f) of these instructions, if a participant in a covered transaction knowingly enters into a lower tier covered transaction with a person who is suspended, debarred, ineligible, or voluntarily excluded from participation in this transaction, in addition to other remedies available to the Federal Government, the department or agency may terminate this transaction for cause or default.

* * * * *

2. Certification Regarding Debarment, Suspension, Ineligibility and Voluntary Exclusion – First Tier Participants:

a. The prospective first tier participant certifies to the best of its knowledge and belief, that it and its principals:

(1) Are not presently debarred, suspended, proposed for debarment, declared ineligible, or voluntarily excluded from participating in covered transactions by any Federal department or agency;

(2) Have not within a three-year period preceding this proposal been convicted of or had a civil judgment rendered against them for commission of fraud or a criminal offense in connection with obtaining, attempting to obtain, or performing a public (Federal, State or local) transaction or contract under a public transaction; violation of Federal or State antitrust statutes or commission of embezzlement, theft, forgery, bribery, falsification or destruction of records, making false statements, or receiving stolen property;

(3) Are not presently indicted for or otherwise criminally or civilly charged by a governmental entity (Federal, State or local) with commission of any of the offenses enumerated in paragraph (a)(2) of this certification; and

(4) Have not within a three-year period preceding this application/proposal had one or more public transactions (Federal, State or local) terminated for cause or default.

b. Where the prospective participant is unable to certify to any of the statements in this certification, such prospective participant shall attach an explanation to this proposal.

2. Instructions for Certification - Lower Tier Participants:

(Applicable to all subcontracts, purchase orders and other lower tier transactions requiring prior FHWA approval or estimated to cost \$25,000 or more - 2 CFR Parts 180 and 1200)

a. By signing and submitting this proposal, the prospective lower tier is providing the certification set out below.

b. The certification in this clause is a material representation of fact upon which reliance was placed when this transaction was entered into. If it is later determined that the prospective lower tier participant knowingly rendered an erroneous certification, in addition to other remedies available to the Federal Government, the department, or agency with which this transaction originated may pursue available remedies, including suspension and/or debarment.

c. The prospective lower tier participant shall provide immediate written notice to the person to which this proposal is submitted if at any time the prospective lower tier participant learns that its certification was erroneous by reason of changed circumstances.

d. The terms "covered transaction," "debarred," "suspended," "ineligible," "participant," "person," "principal," and "voluntarily excluded," as used in this clause, are defined in 2 CFR Parts 180 and 1200. You may contact the person to which this proposal is submitted for assistance in obtaining a copy of those regulations. "First Tier Covered Transactions" refers to any covered transaction between a grantee or subgrantee of Federal funds and a participant (such as the prime or general contract). "Lower Tier Covered Transactions" refers to any covered transaction under a First Tier Covered Transaction (such as subcontracts). "First Tier Participant" refers to the participant who has entered into a covered transaction with a grantee or subgrantee of Federal funds (such as the prime or general contractor). "Lower Tier Participant" refers any participant who has entered into a covered transaction with a First Tier Participant or other Lower Tier Participants (such as subcontractors and suppliers).

e. The prospective lower tier participant agrees by submitting this proposal that, should the proposed covered transaction be entered into, it shall not knowingly enter into any lower tier covered transaction with a person who is debarred, suspended, declared ineligible, or

voluntarily excluded from participation in this covered transaction, unless authorized by the department or agency with which this transaction originated.

f. The prospective lower tier participant further agrees by submitting this proposal that it will include this clause titled "Certification Regarding Debarment, Suspension, Ineligibility and Voluntary Exclusion-Lower Tier Covered Transaction," without modification, in all lower tier covered transactions and in all solicitations for lower tier covered transactions exceeding the \$25,000 threshold.

g. A participant in a covered transaction may rely upon a certification of a prospective participant in a lower tier covered transaction that is not debarred, suspended, ineligible, or voluntarily excluded from the covered transaction, unless it knows that the certification is erroneous. A participant is responsible for ensuring that its principals are not suspended, debarred, or otherwise ineligible to participate in covered transactions. To verify the eligibility of its principals, as well as the eligibility of any lower tier prospective participants, each participant may, but is not required to, check the Excluded Parties List System website (<https://www.epls.gov/>), which is compiled by the General Services Administration.

h. Nothing contained in the foregoing shall be construed to require establishment of a system of records in order to render in good faith the certification required by this clause. The knowledge and information of participant is not required to exceed that which is normally possessed by a prudent person in the ordinary course of business dealings.

i. Except for transactions authorized under paragraph e of these instructions, if a participant in a covered transaction knowingly enters into a lower tier covered transaction with a person who is suspended, debarred, ineligible, or voluntarily excluded from participation in this transaction, in addition to other remedies available to the Federal Government, the department or agency with which this transaction originated may pursue available remedies, including suspension and/or debarment.

* * * * *

Certification Regarding Debarment, Suspension, Ineligibility and Voluntary Exclusion-- Lower Tier Participants:

1. The prospective lower tier participant certifies, by submission of this proposal, that neither it nor its principals is presently debarred, suspended, proposed for debarment, declared ineligible, or voluntarily excluded from participating in covered transactions by any Federal department or agency.

2. Where the prospective lower tier participant is unable to certify to any of the statements in this certification, such prospective participant shall attach an explanation to this proposal.

* * * * *

XI. CERTIFICATION REGARDING USE OF CONTRACT FUNDS FOR LOBBYING

This provision is applicable to all Federal-aid construction contracts and to all related subcontracts which exceed \$100,000 (49 CFR 20).

1. The prospective participant certifies, by signing and submitting this bid or proposal, to the best of his or her knowledge and belief, that:

a. No Federal appropriated funds have been paid or will be paid, by or on behalf of the undersigned, to any person for influencing or attempting to influence an officer or employee of any Federal agency, a Member of Congress, an officer or employee of Congress, or an employee of a Member of Congress in connection with the awarding of any Federal contract, the making of any Federal grant, the making of any Federal loan, the entering into of any cooperative agreement, and the extension, continuation, renewal, amendment, or modification of any Federal contract, grant, loan, or cooperative agreement.

b. If any funds other than Federal appropriated funds have been paid or will be paid to any person for influencing or attempting to influence an officer or employee of any Federal agency, a Member of Congress, an officer or employee of Congress, or an employee of a Member of Congress in connection with this Federal contract, grant, loan, or cooperative agreement, the undersigned shall complete and submit Standard Form-LLL, "Disclosure Form to Report Lobbying," in accordance with its instructions.

2. This certification is a material representation of fact upon which reliance was placed when this transaction was made or entered into. Submission of this certification is a prerequisite for making or entering into this transaction imposed by 31 U.S.C. 1352. Any person who fails to file the required certification shall be subject to a civil penalty of not less than \$10,000 and not more than \$100,000 for each such failure.

3. The prospective participant also agrees by submitting its bid or proposal that the participant shall require that the language of this certification be included in all lower tier subcontracts, which exceed \$100,000 and that all such recipients shall certify and disclose accordingly.

ATTACHMENT A - EMPLOYMENT AND MATERIALS PREFERENCE FOR APPALACHIAN DEVELOPMENT HIGHWAY SYSTEM OR APPALACHIAN LOCAL ACCESS ROAD CONTRACTS

This provision is applicable to all Federal-aid projects funded under the Appalachian Regional Development Act of 1965.

1. During the performance of this contract, the contractor undertaking to do work which is, or reasonably may be, done as on-site work, shall give preference to qualified persons who regularly reside in the labor area as designated by the DOL wherein the contract work is situated, or the subregion, or the Appalachian counties of the State wherein the contract work is situated, except:

a. To the extent that qualified persons regularly residing in the area are not available.

b. For the reasonable needs of the contractor to employ supervisory or specially experienced personnel necessary to assure an efficient execution of the contract work.

c. For the obligation of the contractor to offer employment to present or former employees as the result of a lawful collective bargaining contract, provided that the number of nonresident persons employed under this subparagraph (1c) shall not exceed 20 percent of the total number of employees employed by the contractor on the contract work, except as provided in subparagraph (4) below.

2. The contractor shall place a job order with the State Employment Service indicating (a) the classifications of the laborers, mechanics and other employees required to perform the contract work, (b) the number of employees required in each classification, (c) the date on which the participant estimates such employees will be required, and (d) any other pertinent information required by the State Employment Service to complete the job order form. The job order may be placed with the State Employment Service in writing or by telephone. If during the course of the contract work, the information submitted by the contractor in the original job order is substantially modified, the participant shall promptly notify the State Employment Service.

3. The contractor shall give full consideration to all qualified job applicants referred to him by the State Employment Service. The contractor is not required to grant employment to any job applicants who, in his opinion, are not qualified to perform the classification of work required.

4. If, within one week following the placing of a job order by the contractor with the State Employment Service, the State Employment Service is unable to refer any qualified job applicants to the contractor, or less than the number requested, the State Employment Service will forward a certificate to the contractor indicating the unavailability of applicants. Such certificate shall be made a part of the contractor's permanent project records. Upon receipt of this certificate, the contractor may employ persons who do not normally reside in the labor area to fill positions covered by the certificate, notwithstanding the provisions of subparagraph (1c) above.

5. The provisions of 23 CFR 633.207(e) allow the contracting agency to provide a contractual preference for the use of mineral resource materials native to the Appalachian region.

6. The contractor shall include the provisions of Sections 1 through 4 of this Attachment A in every subcontract for work which is, or reasonably may be, done as on-site work.

AMENDMENT
REQUIRED CONTRACT PROVISIONS
(Exclusive of Appalachian Contracts)

FEDERAL-AID CONSTRUCTION CONTRACTS

The Federal–Aid provisions are supplemented with the following:

XII. Cargo Preference Act

1. U.S. Department of Transportation Federal Highway Administration memorandum dated December 11, 2015 requires that all federal-aid highway programs awarded after February 15, 2016 must comply with the Cargo Preference Act and its regulation of 46 CFR 381.7 (a)-(b).

APPENDIX C

BID PROPOSAL DOCUMENTS

INCLUDING:

Notice to Contractor

Proposal Form

Local Agency Certification for Federal-Aid Contracts

Non-Collusion Declaration

Proposal Signature Page

Contractor Certification Wage Law Compliance (see conditions in 1-02.6 Special Provisions and Amendments)

Disadvantaged Business Enterprise Utilization Certification

Disadvantaged Business Enterprise (DBE) Written Confirmation Document



Lewis County Department of Public Works

Josh S. Metcalf, PE, Director

Tim Fife, PE, County Engineer

NOTICE TO CONTRACTORS

NOTICE IS HERBY GIVEN that the Board of County Commissioners of Lewis County or designee will open sealed proposals and publicly read them aloud on or after 11:00 A.M. on **Tuesday, July 30, 2019**, at the Lewis County Courthouse in Chehalis, Washington, for the Interstate Avenue Paving Project - CRP 2187D. This contract provides for the improvement of ***** Interstate Avenue by pavement repair, planing bituminous pavement, cleaning, sweeping, applying tack coat, paving with HMA, approach transitions, shoulder finishing, traffic control, ***** and other work, all in accordance with the attached Contract Plans, these Contract Provisions, and the Standard Specifications.

SEALED BIDS MUST BE DELIVERED BY OR BEFORE 11:00 A.M. on Tuesday, July 30, 2019

(Lewis County official time is displayed on Axxess Intertel phones in the office of the Board of County Commissioners. **Bids submitted after 11:00 AM will not be considered for this project.**)

Sealed proposals must be delivered to the Lewis County Commissioners Office (351 N.W. North Street, Room 209, CMS-01, Chehalis, Washington 98532), by or before **11:00 A.M.** on the date specified for delivery, and in an envelope clearly marked: **“SEALED BID FOR THE INTERSTATE AVENUE PAVING PROJECT - CRP 2187D, F. A. PROJECT NO. STPUS-HIPUS-5686(001), TO BE OPENED ON OR AFTER 11:00 A.M. ON JULY 30, 2019.”**

All bid proposals shall be accompanied by a bid proposal deposit in cash, certified check, cashier's check or surety bond in an amount equal to five percent (5%) of the amount of such bid proposal. Should the successful bidder fail to enter into such contract and furnish satisfactory performance bond within the time stated in the specifications, the bid proposal deposit shall be forfeited to the Lewis County Public Works Department.

Informational copies of maps, plans and specifications are on file for inspection in the office of the County Engineer of Lewis County in Chehalis, Washington. The contract documents may be viewed and downloaded from Lewis County's Web Site @ www.lewiscountywa.gov or you may call the Lewis County Engineers office @ (360)740-2612 and request a copy be mailed to you.

The Lewis County Public Works Department in accordance with Title VI of the Civil Rights Act of 1964, 78 Stat. 252, 42 U.S.C. 2000d to 2000d-4 and Title 49, Code of Federal Regulations, Department of Transportation, subtitle A, Office of the Secretary, Part 21, nondiscrimination in Federally assisted programs of the Department of Transportation issued pursuant to such Act, hereby notifies all bidders that it will affirmatively insure that in any contract entered into pursuant to this advertisement, disadvantaged business enterprises as defined at 49 CFR Part 26 will be afforded full opportunity to submit bids in response to this invitation and will not be discriminated against on the grounds of race, color, or national origin, or sex in consideration for an award.

Proposal

TO: BOARD OF COUNTY COMMISSIONERS
LEWIS COUNTY
CHEHALIS, WASHINGTON 98532

This certifies that the undersigned has examined the location of the Interstate Avenue Paving Project, CRP 2187D, F.A. Project No. STPUS-HIPUS-5686(001), in Lewis County, Washington, and that the plans, specifications and contract governing the work embraced in these improvements, and the method by which payment will be made for said work is understood. The undersigned hereby proposes to undertake and complete the work embraced in this improvement, or as much thereof as can be completed with the money available in accordance with the said plans, specifications and contract, and

NOTE: Unit prices for all items, all extensions, and total amount of bid shall be shown: All entries must be typed or entered in ink.

| ITEM NO. | PLAN QUANTITY | ITEM DESCRIPTION | UNIT PRICE DOLLARS CENTS | AMOUNT DOLLARS CENTS |
|----------|---------------|---|--------------------------|----------------------|
| 1 | 1 L.S. | Mobilization | Lump Sum | \$ |
| 2 | 1 L.S. | Clearing and Grubbing | Lump Sum | \$ |
| 3 | 1 L.S. | Removal of Structures and Obstructions | Lump Sum | \$ |
| 4 | 3,620 S.Y. | Pavement Repair Excavation Incl. Haul | \$ | \$ |
| 5 | 1.4 MILE | Shoulder Finishing | \$ | \$ |
| 6 | 10 TON | Asphalt for Fog Seal | \$ | \$ |
| 7 | 7,905 S.Y. | Planing Bituminous Pavement | \$ | \$ |
| 8 | 515 TON | HMA For Pavement Repair CL. 3/8 IN. PG 58H-22 | \$ | \$ |
| 9 | 3300 TON | HMA CL. 3/8 IN. PG 58H-22 Fiber Reinforced | \$ | \$ |
| 10 | 130 TON | HMA For Approach CL. 3/8 IN. PG 58H-22 | \$ | \$ |
| 11 | 5 EACH | Inlet Protection | \$ | \$ |
| 12 | 20,430 L.F. | Plastic Line | \$ | \$ |
| 13 | 420 L.F. | Plastic Wide Lane Line | \$ | \$ |
| 14 | 4 EACH | Plastic Traffic Arrow | \$ | \$ |
| 15 | 288 S.F. | Plastic Crosswalk Line | \$ | \$ |
| 16 | 18 L.F. | Plastic Stop Line | \$ | \$ |
| 17 | 9 EACH | Plastic Traffic Letter | \$ | \$ |
| 18 | 1 L.S. | Project Temporary Traffic Control | Lump Sum | \$ |
| 19 | 1 L.S. | Traffic Control Supervisor | Lump Sum | \$ |
| 20 | 700 HR | Flaggers | \$ | \$ |
| 21 | 450 S.F. | Construction Signs Class A | \$ | \$ |
| 22 | 110 HR | Other Traffic Control Labor | \$ | \$ |
| 23 | 1 EACH | Adjust Manhole | \$ | \$ |
| 24 | 11 EACH | Adjust Valve Box | \$ | \$ |
| 25 | 56 S.F. | Detectable Warning Surface | \$ | \$ |
| 26 | 1 L.S. | Trimming And Cleanup | Lump Sum | \$ |
| 27 | 3 EACH | Mailbox Support Type 1 | \$ | \$ |
| 28 | 0 EST. | Reimbursement For Third Party Damage | Estimated | \$0.00 |
| 29 | 1 CALC | Minor Change | Lump Sum | \$25,000.00 |
| | | | Total | |

Local Agency Certification for Federal-Aid Contracts

The prospective participant certifies by signing and submitting this bid or proposal, to the best of his or her knowledge and belief, that:

(1) No Federal appropriated funds have been paid or will be paid, by or on behalf of the undersigned, to any person for influencing or attempting to influence an officer or employee of any Federal agency, a Member of Congress, an officer or employee of Congress, or an employee of a Member of Congress in connection with the awarding of any Federal contract, the making of any Federal grant, the making of any Federal loan, the entering into of any cooperative agreement, and the extension, continuation, renewal, amendment, or modification of any Federal contract, grant, loan or cooperative agreement.

(2) If any funds other than Federal appropriated funds have been paid or will be paid to any person for influencing or attempting to influence an officer or employee of any Federal agency, a Member of Congress, an officer or employee of Congress, or an employee of a Member of Congress in connection with this Federal contract, grant, loan, or cooperative agreement, the undersigned shall complete and submit Standard Form-LLL, "Disclosure Form to Report Lobbying," in accordance with its instructions.

This certification is material representation of the fact upon which reliance was placed when this transaction was made or entered into. Submission of this certification is a prerequisite for making or entering into this transaction imposed by Section 1352, Title 31, U.S. Code. Any person who fails to file the required certification shall be subject to a civil penalty of not less than \$10,000 and not more than \$100,000 for each failure.

The prospective participant also agrees by submitting his or her bid or proposal that he or she shall require that the language of this certification be included in all lower tier subcontracts, which exceed \$100,000 and that all such subrecipients shall certify and disclose accordingly.

SR

DOT Form 272-040A EF
07/2011

Failure to return this Declaration as part of the bid proposal package will make the bid nonresponsive and ineligible for award.

NON-COLLUSION DECLARATION

I, by signing the proposal, hereby declare, under penalty of perjury under the laws of the United States that the following statements are true and correct:

1. That the undersigned person(s), firm, association or corporation has (have) not, either directly or indirectly, entered into any agreement, participated in any collusion, or otherwise taken any action in restraint of free competitive bidding in connection with the project for which this proposal is submitted.
2. That by signing the signature page of this proposal, I am deemed to have signed and to have agreed to the provisions of this declaration.

NOTICE TO ALL BIDDERS

To report rigging activities call:

1-800-424-9071

The U.S. Department of Transportation (USDOT) operates the above toll-free "hotline" Monday through Friday, 8:00 a.m. to 5:00 p.m., eastern time. Anyone with knowledge of possible bid rigging, bidder collusion, or other fraudulent activities should use the "hotline" to report such activities.

The "hotline" is part of USDOT's continuing effort to identify and investigate highway construction contract fraud and abuse and is operated under the direction of the USDOT Inspector General. All information will be treated confidentially and caller anonymity will be respected.

PROPOSAL - SIGNATURE PAGE

The bidder is hereby advised that by signature of this proposal he/she is deemed to have acknowledged all requirements and signed all certificates contained herein.

A proposal guaranty in an amount of five percent (5%) of the total bid, based upon the approximate estimate of quantities at the above prices and in the form as indicated below, is attached hereto:

CASH IN THE AMOUNT OF _____

CASHIER'S CHECK _____ DOLLARS

CERTIFIED CHECK (\$ _____) PAYABLE TO THE LEWIS COUNTY TREASURER

PROPOSAL BOND IN THE AMOUNT OF 5% OF THE BID

** Receipt is hereby acknowledged of addendum(s) No.(s) _____, _____, _____, & _____

SIGNATURE OF AUTHORIZED OFFICIAL(S)

Proposal Must be Signed

Firm Name

Address

State of Washington Contractor's License No.

Unified Business Identifier (U.B.I.) No.

Federal ID No.

Note:

This proposal form is not transferable and any alteration of the firm's name entered hereon without prior permission from the Lewis County Engineer will be cause for considering the proposal irregular and subsequent rejection of the bid.

*Attach Power of Attorney

Instructions for Underutilized Disadvantaged Business Enterprise Utilization Certification Form

Box 1: Name of Bidder (Proposal holder) submitting Bid.

Box 2: Name of the Project.

Column 1: Name of the Underutilized Disadvantaged Business Enterprise (UDBE). UDBE Firms can be found using the search tools under the Firm Certification section of the Diversity Management and Compliance System web page <https://wsdot.diversitycompliance.com> Repeat the name of the UDBE for each Project Role that will be performed.

Column 2: The Project Role that the UDBE will be performing as follows;

- Prime Contractor
- Subcontractor
- Subcontractor (Force Account)
 - Work sublet as Force Account must be listed separately.
- Manufacturer
- Regular Dealer
 - Work sublet to a Regular Dealer must be listed separately.
 - Regular Dealer status must be approved prior to Bid submittal by the Office of Equal Opportunity, Washington State Department of Transportation, on each Contract.
- Broker
 - Work sublet to a Broker must be listed separately.

List each project role to be performed by a single UDBE individually on a separate row(s). The role is used to determine what portion of the amount to be subcontracted (Column 4) may be applied toward meeting the goal (column 5).

Column 3: Provide a description of the work to be performed by the UDBE. The work to be performed must be consistent with the Certified Business Description of the UDBE provided at the Diversity Management and Compliance System web page <https://wsdot.diversitycompliance.com>

- A Bidder subletting a portion of a bid item shall state "Partial" and describe the Work that is included.
 - For example; "Electrical (Partial) – Trenching".
- "Mobilization" will not be accepted as a description of Work.

Column 4: List the total amount to be subcontracted to each UDBE for each Project Role they are performing.

Column 5: This is the dollar amount for each line listed in the certification that the prime intends to apply towards meeting the COA Contract goal. It may be that only a portion of the amount subcontracted to a UDBE in Column 4 is eligible to be credited toward meeting the goal See **Note 1**, **Note 2**, **Note 3**. The Contracting Agency will utilize the sum of this column (Box 4) to determine whether or not the bidder has met the goal. In the event of an arithmetic error in summing column 5 or an error in making appropriate reductions in the amounts in column four, See **Note 1**, **Note 2**, **Note 3**, then the mathematics will be corrected and the total (Box 4) will be revised accordingly.

Note 1: For Work sublet as Force Account the bidder **may only claim 50%** of the amount subcontracted (Column 4) towards meeting the goal (Column 5). This information will be used to demonstrate that the UDBE contract goal is met at the time that the bidder submits their bid. For example; amount sublet as force account = \$100,000 (Column 4) equates to $(\$100,000 \times 50\%) = \$50,000$ (Column 5) to be applied towards the goal.

Note 2: For Work sublet to a Regular Dealer the bidder **may only claim 60%** of the cost of the materials or supplies (Column 4) towards meeting the goal (Column 5). For example; Material cost = \$100,000 (Column 4) equates to $(\$100,000 \times 60\%) = \$60,000$ (Column 5) to be applied towards the goal.

Note 3: For Work sublet to a Broker the bidder **may only claim the fees** paid to a Broker towards meeting the goal (Column 4). For example; amount sublet to a broker = \$100,000 (Column 4) equates to $(\$100,000 \times \text{reasonable fee \%}) = \$$ (Column 5) to be applied towards the goal.

Box 3: Box 3 is the COA Contract goal which is the minimum required UDBE participation. The goal stated in the Contract will be in terms of a dollar amount or a percentage in the Contract. When expressed as a percentage you must multiply the percentage times the sum total of all bid items as submitted in the Bidder's Proposal to determine the dollar goal and write it in Box 3. In the event of an error in this box, the Contracting Agency will revise the amount accordingly.

Box 4: Box 4 is the sum of the values in column 5. **This value must equal or exceed the COA Contract goal amount written in Box 3 or;**

Box 5: Check Box 5 if insufficient UDBE Participation has been achieved and a good faith effort is required. Refer to the subsection titled, *Selection of Successful Bidder/Good Faith Efforts (GFE)* in the Contract.

See the *Disadvantaged Business Enterprise Participation* specification in the Contract for more information.

Underutilized Disadvantaged Business Enterprise Utilization Certification

To be eligible for Award of this Contract the Bidder shall fill out and submit, as a supplement to its sealed Bid Proposal, an Underutilized Disadvantaged Business Enterprise (UDBE) Utilization Certification. The Contracting Agency shall consider as non-responsive and shall reject any Bid Proposal that does not contain a UDBE Utilization Certification which properly demonstrates that the Bidder will meet the UDBE participation requirements in one of the manners provided for in the proposed Contract. **Refer to the instructions on Page 2 when filling out this form or the Bid may be rejected. An example form has been provided on Page 3.** The successful Bidder's UDBE Utilization Certification shall be deemed a part of the resulting Contract.

Box 1: A Plus Construction Company certifies that the UDBE firms listed below have been contacted regarding participation on this project. If this Bidder is successful on this project and is awarded the Contract, it shall assure that subcontracts or supply agreements are executed with named UDBEs. (If necessary, use additional sheets.)

Box 2: US 395, Spokane City Limits to Stevens County Line - Paving and Safety

| Column 1 Name of UDBE <small>(See Instructions)</small> | Column 2 Project Role <small>(See Instructions)</small> | Column 3 Description of Work <small>(See Instructions)</small> | Column 4 Dollar Amount Subcontracted to UDBE <small>(See Instructions)</small> | Column 5 Dollar Amount to be Applied Towards Goal <small>(See Instructions)</small> |
|---|---|---|--|---|
| A Plus Construction Company | Prime | Asphalt and concrete paving, asphalt milling, preleveling and pavement repair | N/A | 900,000 |
| In the Line Services, Inc. | Subcontractor (Force Account) | Crack sealing | 20,000 | 10,000 |
| In the Line Services, Inc. | Subcontractor | Guideposts, joint seal, pavement markers, temporary signage, construction sign installation | 200,000 | 200,000 |
| The Everything Guys, LLC | Regular Dealer | Rental and sales of highway construction and related equipment and materials | 100,000 | 60,000 |
| Optimus Prime Trucking, Inc. | Subcontractor | Dump Trucking | 50,000 | 50,000 |
| Metalheads, Inc. | Manufacturer | Dowel Bars | 75,000 | 75,000 |
| Erosion Under Control Co. | Broker | Erosion control blankets, straw bales and wattles, sand bags | 15,000 | 250 |
| | | | | |
| | | | | |
| | | | | |
| | | | | |
| | | | | |
| | | | | |
| | | | | |
| | | | | |
| | | | | |
| | | | | |
| | | | | |
| | | | | |
| | | | | |
| | | | | |
| | | | | |
| | | | | |

EXAMPLE

Underutilized Disadvantaged Business Enterprise Condition of Award Contract Goal 356,968.16 Box 3 Total UDBE Commitment Dollar Amount 1,295,250 Box 4

5 By checking Box 5 the Bidder is stating that their attempts to solicit sufficient UDBE participation to meet the COA Contract goal has been unsuccessful and good faith effort will be submitted in accordance with Section 1-02.9 of the Contract



Underutilized Disadvantaged Business Enterprise (UDBE) Written Confirmation Document

See Contract Provisions: *UDBE Document Submittal Requirements*
Disadvantaged Business Enterprise Participation

THIS FORM SHALL ONLY BE SUBMITTED TO A UDBE THAT IS LISTED ON THE CONTRACTOR'S UNDERUTILIZED DISADVANTAGED BUSINESS ENTERPRISE UTILIZATION CERTIFICATION.

THE CONTRACTOR SHALL COMPLETE PART A PRIOR TO SENDING TO THE UDBE.

PART A: To be completed by the bidder

The entries below shall be consistent with what is shown on the Bidder's Underutilized Disadvantaged Business Enterprise Utilization Certification. Failure to do so will result in Bid rejection.

Contract Title: _____

Bidder's Business Name: _____

UDBE's Business Name: _____

Description of UDBE's Work: _____

Dollar Amount to be Applied Towards UDBE Goal: _____

Dollar Amount to be Subcontracted to UDBE*: _____
*Optional Field

PART B: To be completed by the Underutilized Disadvantaged Business Enterprise

As an authorized representative of the Underutilized Disadvantaged Business Enterprise, I confirm that we have been contacted by the Bidder with regard to the referenced project for the purpose of performing the Work described above. If the Bidder is awarded the Contract, we will enter into an agreement with the Bidder to participate in the project consistent with the information provided in Part A of this form.

Name (printed): _____

Signature: _____

Title: _____

Address: _____ Date: _____

APPENDIX D

CONTRACT DOCUMENTS

INCLUDING:

Contract Form

Performance Bond

Power Equipment List

CONTRACT

THIS AGREEMENT, made and entered into this ___ day of _____, 2019, between the BOARD OF COUNTY COMMISSIONERS of LEWIS COUNTY, State of Washington, acting under and by virtue of RCW 36.77.040, hereinafter called

the Board, and _____ of _____

for ___sel___, heirs, executors, administrators, successors and assigns, hereinafter called the Contractor.

WITNESSETH:

That in consideration of the payments, covenants and agreements hereinafter mentioned to be made and performed by the parties hereto, the parties hereto covenant and agree as follows:

DESCRIPTION OF WORK:

1. The Contractor shall do all work and furnish all material necessary to improve *** Interstate Avenue by pavement repair, planing bituminous pavement, cleaning, sweeping, applying tack coat, paving with reinforced fiber HMA, approach transitions, shoulder finishing, traffic control,*** and other work all in Lewis County Washington, in accordance with and as described in the attached plans and specifications, and in full compliance with the terms, conditions and stipulations herein set forth and attached, now referred to and by such reference incorporated herein and made a part hereof as fully for all purposes as if here set forth at length, and shall perform any alterations in or additions to the work covered by this contract and every part thereof and any extra work which may be ordered as provided in this contract and every part thereof.

The Contractor shall provide and be at the expense of all materials, labor, carriage, tools, implements and conveniences and things of every description that may be requisite for the transfer of materials and for constructing and completing the work provided for in this contract and every part thereof.

2. The County hereby promises and agrees with the Contractor to hire and does hire the Contractor to provide the materials and to do and cause to be done the above described work and to complete and furnish the same according to the attached plans and specifications and the terms and conditions herein contained, and hereby contracts to pay for the same according to the schedule of unit or itemized prices at the time and in the manner and upon the conditions provided for in this contract and every part thereof. The County further agrees to hire the contractor to perform any alterations in or conditions to the work covered by this contract and every part thereof and any force account work that may be ordered and to pay for the same under the terms of this contract and the attached plans and specifications.

3. The Contractor for himself, and for his heirs, executors, administrators, successors and assigns, does hereby agree to the full performance of all the covenants herein contained upon the part of the Contractor.

4. It is further provided that no liability shall attach to the County by reason of entering into this contract, except as expressly provided herein.

Contract - 1

5. CANCELLATION OF CONTRACT FOR VIOLATION OF STATE POLICY

This contract, pursuant to RCW 49.28.040 to RCW 49.28.060, may be canceled by the officers or agents of the Owner authorized to contract for or supervise the execution of such work, in case such work is not performed in accordance with the policy of the State of Washington.

6. DOCUMENTS COMPRISING CONTRACT

All documents hereto attached, including but not being limited to the advertisement for bids, information for bidders, bid proposal form, general conditions (if any), special conditions (if any), complete specifications and the complete plans, are hereby made a part of this contract.

IN WITNESS WHEREOF, the said Contractor has executed this instrument, and the said Board of County Commissioners of aforesaid County, pursuant to resolution duly adopted, has caused this instrument to be executed by and in the name of said Board by its Chairman, duly attested by its Clerk, the day and year first above written, and the seal of said Board to be hereunto affixed on the date in this instrument first above written.

By: _____

Contractor

Performance of foregoing contract assured in accordance with the terms of the accompanying bond.

Dated: _____, 2019

By: _____

Surety

By: _____

Attorney-in-fact

APPROVED AS TO FORM:

JONATHAN L. MEYER, Prosecuting Attorney

By: _____

Civil Deputy

APPROVED:

County Engineer

Contract – 2

**PERFORMANCE BOND FOR
LEWIS COUNTY, WASHINGTON**

Bond No. _____

WE, _____ d/b/a _____
(Insert legal name of Contractor) (Insert trade name of Contractor, if any)

(hereinafter "Principal"), and _____ (hereinafter "Surety"), are held and firmly bound unto **LEWIS COUNTY, WASHINGTON** (hereinafter "County"), as Obligee, in an amount (in lawful money of the United States of America) equal to the total compensation and expense reimbursement payable to Principal for satisfactory completion of Principal's work under Contract No. **CRP 2187D, F.A. Project No. STPUS-HIPUS-5686(001)**, between Principal and County, which total is *initially* _____ Dollars (\$ _____), for the payment of which sum Principal and Surety bind themselves, their executors, administrators, legal representatives, successors and assigns, jointly and severally, firmly by these presents. Said contract (hereinafter referred to as "the Contract") is for the **Interstate Avenue Paving Project**, and is made a part hereof by this reference. The Contract includes the original agreement as well as all documents attached thereto or made a part thereof and amendments, change orders, and any other document modifying, adding to or deleting from said Contract any portion thereof.

This Bond is executed in accordance with the laws of the State of Washington, and is subject to all provisions thereof and the ordinances of County insofar as they are not in conflict therewith, and is entered into for the use and benefit of County, and all laborers, mechanics, subcontractors, and materialmen, and all persons who supply such person or persons, or subcontractors, with provisions or supplies for the carrying on of the work covered by Contract No. **CRP 2187D, F.A. Project No. STPUS-HIPUS-5686(001)**, between the below-named Contractor and County for the **Interstate Avenue Paving Project**, a copy of which Contract, by this reference is made a part hereof and is hereinafter referred to as "the Contract." (The Contract as defined herein includes the aforesaid agreement together with all of the Contract documents including addenda, exhibits, attachments, modifications, alterations, and additions thereto, deletions therefrom, amendments and any other document or provision attached to or incorporated into the Contract)

THE CONDITION OF THIS OBLIGATION is such that if Contractor shall promptly and faithfully perform the Contract, then this obligation shall be null and void; otherwise it shall remain in full force and effect.

THE PARTIES FURTHER ACKNOWLEDGE & AGREE AS FOLLOWS:

- (1) Surety hereby consents to, and waives notice of, any alteration, change order, or other modification of the Contract and any extension of time made by County, except that any single or cumulative change order amounting to more than twenty-five percent (25%) of the penal sum of this bond shall require Surety's written consent.
- (2) Surety recognizes that the Contract includes provisions for additions, deletions, and modifications to the work or Contract Time and the amounts payable to Contractor. Subject to the limitations contained in paragraph (1) above, no such change or any combination thereof, shall void or impair Surety's obligation hereunder.
- (3) Surety is subject to the provisions contained in Section 1-03.4, "Contract Bond," of the Washington State Department of Transportation (WSDOT) Standard Specifications for Road, Bridge, and Municipal Construction, and such provisions are incorporated by reference. A copy may be viewed at WSDOT's website www.wsdot.wa.gov/Publications/Manuals/.
- (4) Whenever County has declared Contractor to be in default and County has given Surety written notice of such declaration, Surety shall promptly (in no event more than thirty [30] days following receipt of such notice), specify, in written notice to County, which of the following actions Surety intends to take to remedy such default, and thereafter shall:
 - (a) Remedy the default within fifteen (15) days after its notice to County, as stated in such notice; or
 - (b) Assume within fifteen (15) days following its notice to County, full responsibility for the completion of the Contract in accordance with all of its provisions, as stated in such notice, and become entitled to payment of the balance of the Contract sum as provided in the Contract; or
 - (c) Pay County upon completion of the Contract, in cash, the cost of completion together with all other reasonable costs and expenses incurred by County as a result of Contractor's default, including but not limited to those incurred by County to mitigate its losses, which may include but are not limited to attorneys' fees and the cost of efforts to complete the work prior to Surety's exercising any option available to it under this Bond; or
 - (d) Obtain a bid or bids for completing the Contract in accordance with its terms and conditions, and upon a determination by County and Surety jointly of the lowest responsible bidder, arrange for one or more agreements between such bidder and County, and make available as work progresses (even though there is a default or a succession of defaults under such agreement(s) for completion arranged for under this paragraph) sufficient funds to pay the cost of completion less the balance of the Contract price, but not exceeding, including other costs and damages for which Surety may be liable hereunder, the penal sum of this Bond. The term "balance of the Contract price," as used in this paragraph, shall mean the total amount payable by County to Contractor under the Contract, less the amount properly paid by County to Contractor.

(5) If County commences suit and obtains judgment against Surety for recovery hereunder, then Surety, in addition to such judgment, shall pay all costs and attorneys' fees incurred by County in enforcement of County's rights hereunder. The venue for any action arising out of or in connection with this bond shall be in Lewis County, Washington.

(6) No right or action shall accrue on this Bond to or for the use of any person or corporation other than Lewis County, except as herein provided.

(7) No rider, amendment or other document modifies this Bond except as follows, which by this reference is incorporated herein:

SURETY'S QUALIFICATIONS: Every Surety named on this bond must appear on the United States Treasury Department's most current list (Circular 570 as amended or superseded) and be authorized by the Washington State Insurance Commissioner to transact business as a surety in the State of Washington. In addition, the Surety must have a current rating of at least A-:VII in A. M. Best's Key Rating Guide.

INSTRUCTIONS FOR SIGNATURES: This bond must be signed by the president or a vice-president of a corporation; the managing general partner of a partnership; managing joint venturer of a joint venture; manager of a limited liability company or, if no manager has been designated, a member of such LLC; a general partner of a limited liability partnership; or the owner(s) of a sole proprietorship. If the bond is signed by any other representative, the Principal must attach currently-dated, written proof of that signer's authority to bind the Principal, identifying and quoting the provision in the corporate articles of incorporation, bylaws, Board resolution, partnership agreement, certificate of formation, or other document authorizing delegation of signature authority to such signer, and confirmation acceptable to the County that such delegation was in effect on the date the bond was signed. **A NOTARY PUBLIC MUST ACKNOWLEDGE EACH SIGNATURE BELOW.**

FOR THE SURETY:

FOR THE PRINCIPAL:

By _____
(Signature of Attorney-in-Fact)

By: _____
(Signature of authorized signer for Contractor)

(Type or print name of Attorney-in-Fact)

(Type or print name of signer for Contractor)

(Type or print telephone number for Attorney-in-Fact)

(Type or print title of signer for Contractor)

STATE OF _____)
) ss: **ACKNOWLEDGMENT FOR CONTRACTOR**
COUNTY OF _____)

On this ____ day of _____, _____, before me a notary public in and for the State of _____, duly commissioned and sworn, personally appeared _____, the person described in and who executed the foregoing bond, and acknowledged to me that _____ signed and sealed said bond as the free and voluntary act and deed of the Contractor so identified in the foregoing bond for the uses and purposes therein mentioned, and on oath stated that _____ is authorized to execute said bond for the Contractor named therein. WITNESS my hand and official seal hereto affixed the day and year in this certificate first above written.

(Signature of Notary Public) _____
(Print or type name of Notary Public)

Notary Public in and for the State of _____ residing at _____
My commission expires _____ **SEAL →**

STATE OF _____)
) ss: **ACKNOWLEDGMENT FOR SURETY**
COUNTY OF _____)

On this ____ day of _____, _____, before me a notary public in and for the State of _____, duly commissioned and sworn, personally appeared _____, Attorney-in-Fact for the Surety that executed the foregoing bond, and acknowledged said bond to be the free and voluntary act and deed of the Surety for the uses and purposes therein mentioned, and on oath stated that _____ is authorized to execute said bond on behalf of the Surety, and that the seal affixed on said bond or the annexed Power of Attorney is the corporate seal of said Surety. WITNESS my hand and official seal hereto affixed the day and year in this certificate first above written.

(Signature of Notary Public) _____
(Print or type name of Notary Public)

Notary Public in and for the State of _____ residing at _____
My commission expires _____ **SEAL →**

APPENDIX E

TRAFFIC CONTROL PLAN

CONTRACT PLANS

NOTES

- The Detectable Warning Surface (DWS) shall extend the full width of the curb ramp, landing, or other roadway entrance as applicable. Exception: If the Manufacturer of the DWS requires a concrete border around the DWS, a variance of up to 2 inches on each side of the DWS is permitted.
- The Detectable Warning Surface (DWS) shall be placed at the back of curb, with the two leading corners of the DWS panel placed adjacent to the back of the curb, and with no more than a 2 inch gap between the DWS and the back of the curb measured at the center of the DWS panel. Exception: If the Manufacturer of the selected DWS requires a concrete border around the DWS, a variance of up to 2 inches from the back of the curb is permitted (measured at the leading corners of the DWS panel).
- The rows of truncated domes shall be aligned to be perpendicular to the grade break at the back of curb.
- The rows of truncated domes shall be aligned to be parallel to the direction of travel.
- If curb and gutter are not present, such as a shared-use path connection, the Detectable Warning Surface shall be placed at the pavement edge.
- See **Standard Plans** for sidewalk and curb ramp details.
- If a curb ramp is required, the location of the Detectable Warning Surface must be at the bottom of the ramp and within the required distance from the rail.
- When the grade break between the curb ramp and the landing is less than or equal to 5 ft. from the back of curb at all points, place the Detectable Warning Surface on the bottom of the curb ramp directly above the grade break.

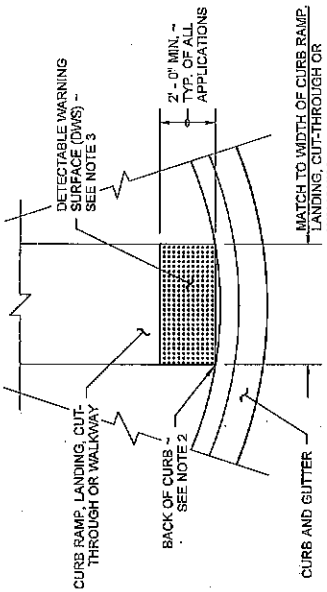

DETECTABLE WARNING SURFACE DETAIL

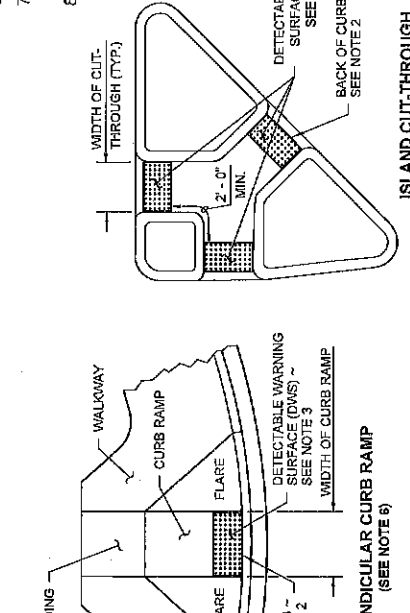

PERPENDICULAR CURB RAMP (SEE NOTE 6)

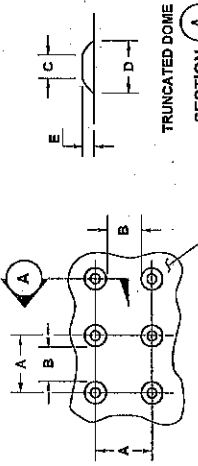
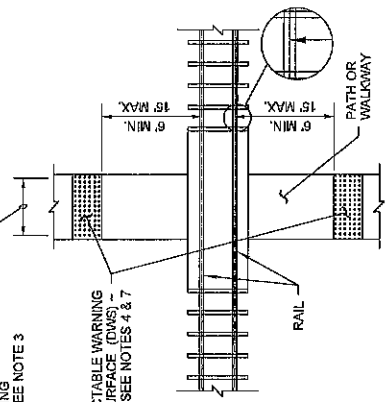

TRUNCATED DOME DETAILS

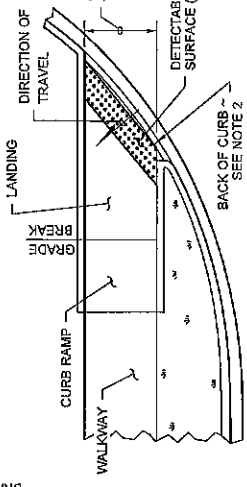
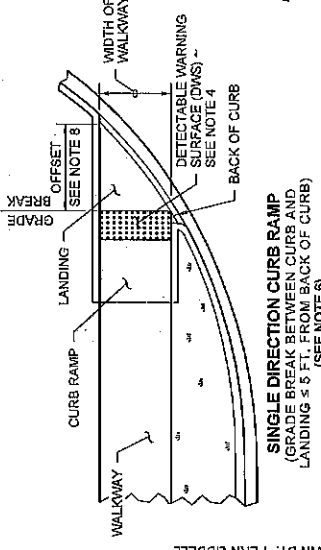

PARALLEL CURB RAMP (SEE NOTE 6)

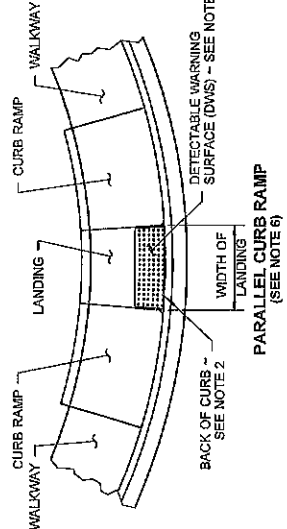

PEDESTRIAN RAILROAD CROSSING

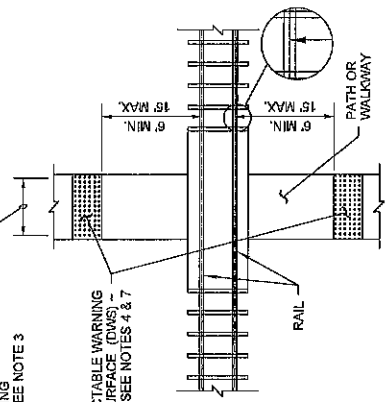

PLACEMENT GUIDELINES

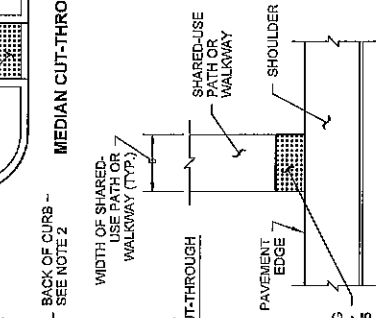

SHARED-USE PATH CONNECTION

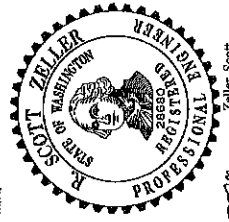

Zeller, Scott
Jul 12 2016 4:42:35 PM

DETECTABLE WARNING SURFACE

STANDARD PLAN F-45.10-02

SHEET 1 OF 1 SHEET

APPROVED FOR PUBLICATION
Compton, Jeff
July 15 2016 2:28 PM

Washington State Department of Transportation
STATE DESIGN ENGINEER

NOTES

- Dimensions for the parts used to assemble the base connections are intentionally not shown. Base connections are patented, manufactured products that are in compliance with NCHRP 350 crash test criteria. The base connection details are shown on this plan only to illustrate how the parts are assembled.
- For "H1", refer to the Sign Specification Sheet in the Contract.
- A 2" (in) post with a 2 1/4" (in) PSSST anchor or a 2 1/4" (in) post with a 2 1/2" (in) PSSST anchor may be substituted. See Contract Plans.
- Perforated square steel post shall meet the requirements of Standard Specification 9-06.
- Use only base connection manufacturer supplied hardware that meets the requirements of Standard Specifications 9-06 and 9-28.

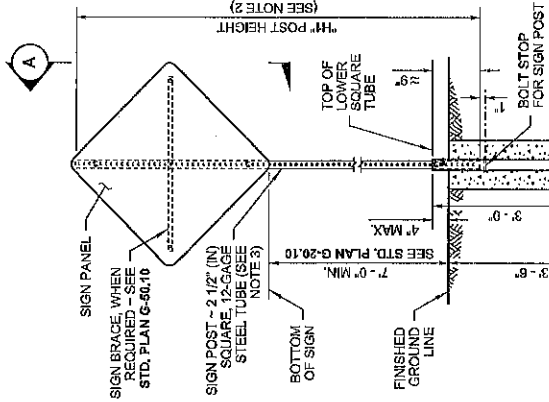

ELEVATION
TYPE ST-1 SIGN SUPPORT

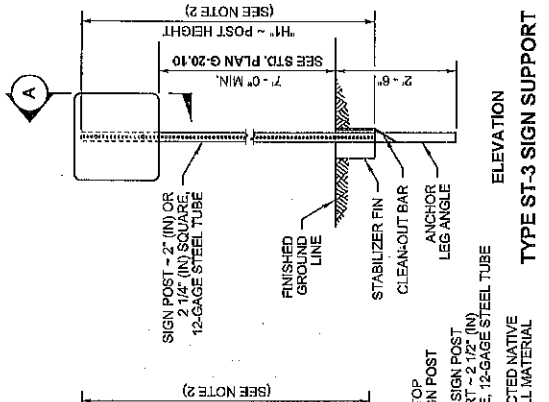

ELEVATION
TYPE ST-2 SIGN SUPPORT

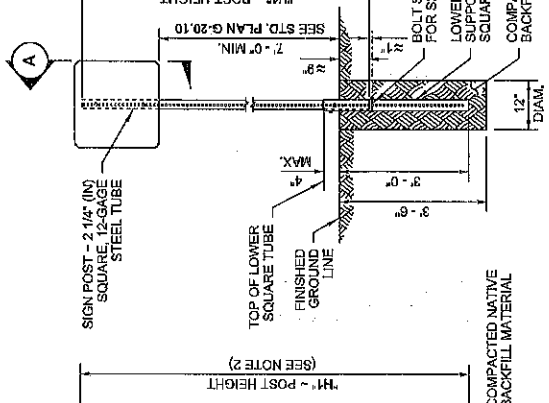

ELEVATION
TYPE ST-3 SIGN SUPPORT

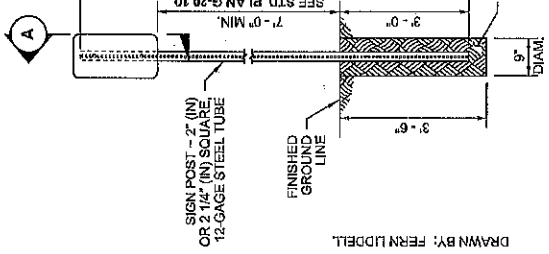

ELEVATION
TYPE ST-4 SIGN SUPPORT

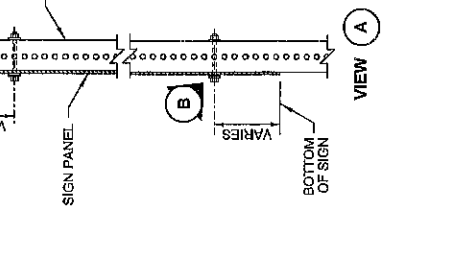
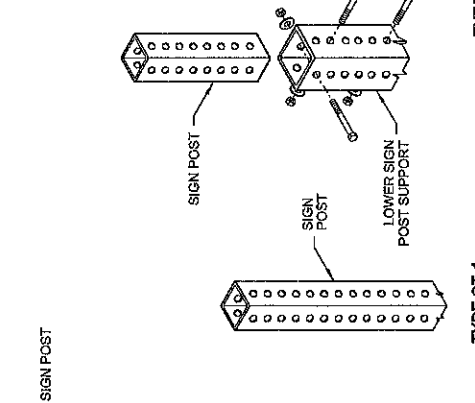
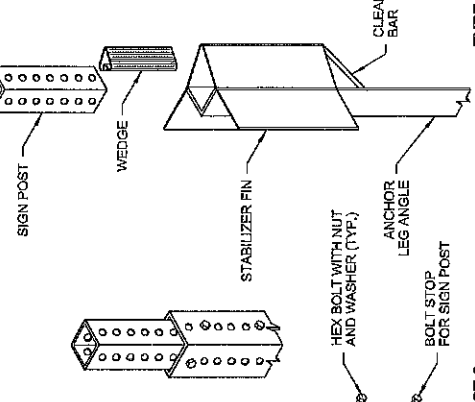
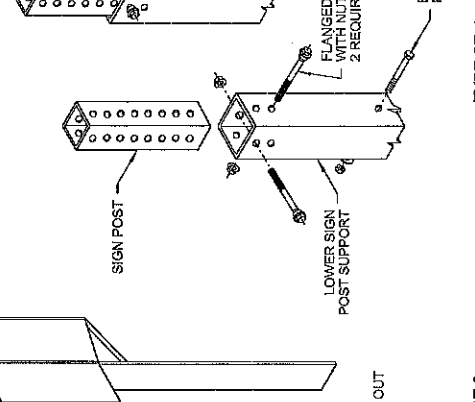
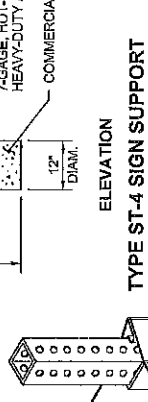

JOHN C. ANTSBET
STATE OF WASHINGTON
REGISTERED PROFESSIONAL ENGINEER
No. 10000
EXPIRES 12/31/2017 5:24 PM

STEEL SIGN SUPPORT
TYPES ST-1 - ST-4
INSTALLATION DETAILS
STANDARD PLAN G-24.50-04
SHEET 1 OF 1 SHEET

APPROVED FOR PUBLICATION
DATE: 11/20/17 12:11 PM
STATE DESIGN ENGINEER
Washington State Department of Transportation

DRAWN BY: FERN LIDDELL

| WOOD POST FASTENERS | | | |
|--------------------------|----------|---------|----------|
| SIZE / TYPE | QUANTITY | WASHERS | LOCKNUTS |
| 3/8" DIAM. x 4 3/4" BOLT | 2 | 4 | 2 |
| 3/8" DIAM. x 3/4" BOLT | 4 | 8 | 4 |
| 3/16" DIAM. x 1" SCREW | 4 | 8 | 4 |

| STEEL POST FASTENERS | | | |
|--------------------------|----------|---------|----------|
| SIZE / TYPE | QUANTITY | WASHERS | LOCKNUTS |
| 3/8" DIAM. x 2 3/4" BOLT | 2 | 4 | 2 |
| 3/8" DIAM. x 3/4" BOLT | 4 | 8 | 4 |
| 3/16" DIAM. x 1" SCREW | 4 | 8 | 4 |
| 1 7/8" M-CLAMP | 2 | 4 | 4 |

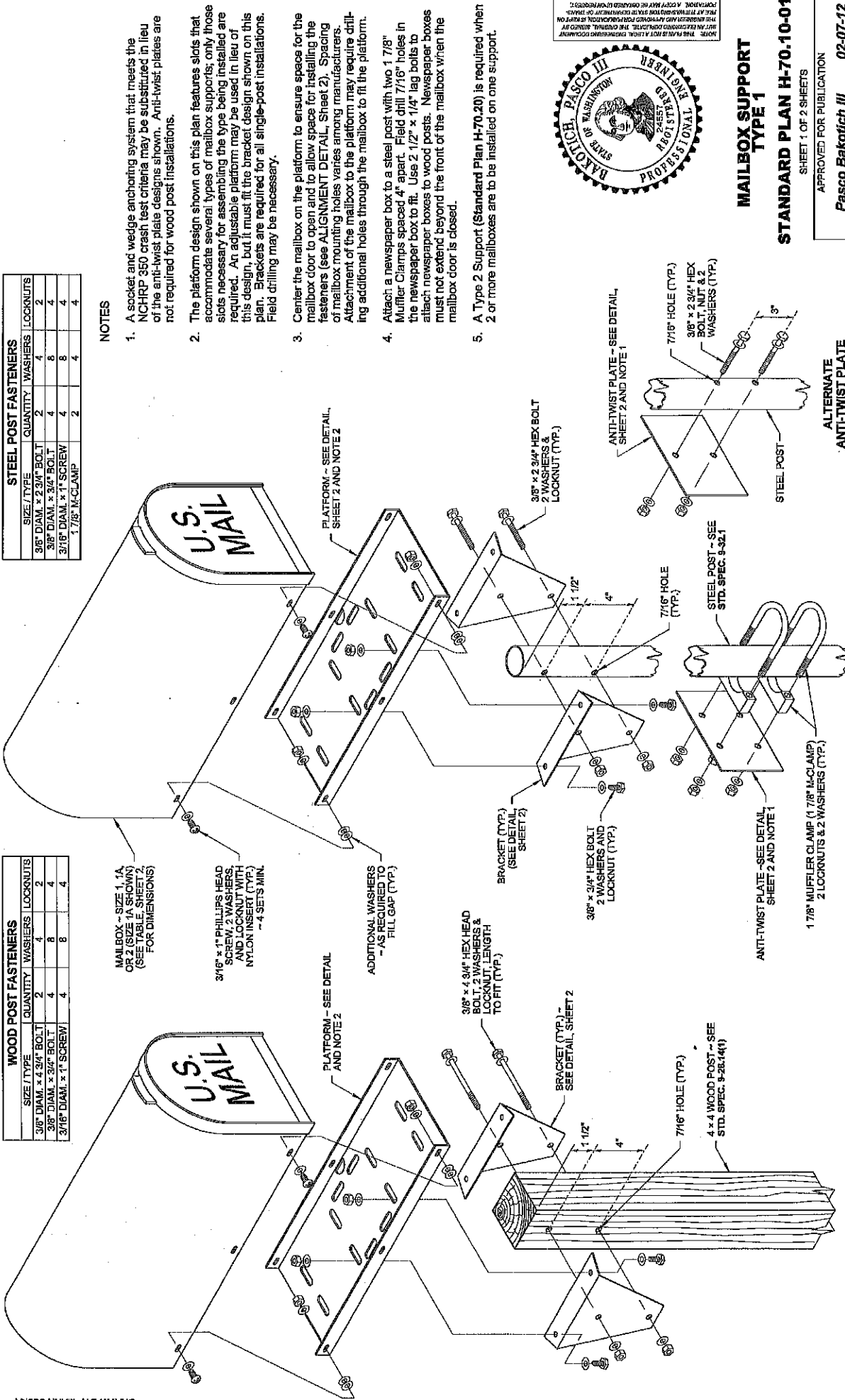

NOTES

1. A socket and wedge anchoring system that meets the NCHRP 360 crash test criteria may be substituted in lieu of the anti-twist plate designs shown. Anti-twist plates are not required for wood post installations.
2. The platform design shown on this plan features slots that accommodate several types of mailbox supports; only those slots necessary for assembling the type being installed are required. An adjustable platform may be used in lieu of this design, but it must fit the bracket design shown on this plan. Brackets are required for all single-post installations. Field drilling may be necessary.
3. Center the mailbox on the platform to ensure space for the mailbox door to open and to allow space for installing the fasteners (see ALIGNMENT DETAIL, Sheet 2). Spacing of mailbox mounting holes varies among manufacturers. Attachment of the mailbox to the platform may require drilling additional holes through the mailbox to fit the platform.
4. Attach a newspaper box to a steel post with two 1 7/8" Muffler Clamps spaced 4" apart. Field drill 7/16" holes in the newspaper box to fit. Use 2 1/2" x 1/4" lag bolts to attach newspaper boxes to wood posts. Newspaper boxes must not extend beyond the front of the mailbox when the mailbox door is closed.
5. A Type 2 Support (Standard Plan H-70.20) is required when 2 or more mailboxes are to be installed on one support.

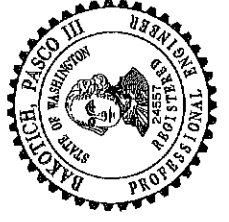

MAILBOX SUPPORT TYPE 1
STANDARD PLAN H-70.10-01

SHEET 1 OF 2 SHEETS

APPROVED FOR PUBLICATION

Pasco Bakofch III 02-07-12
STATE DESIGN ENGINEER DATE

Washington State Department of Transportation

ALTERNATE ANTI-TWIST PLATE DESIGN

STEEL POST ASSEMBLY DETAIL

WOOD POST ASSEMBLY DETAIL
SEE STEEL POST ASSEMBLY DETAIL FOR SPECIFICATIONS NOT SHOWN

NOTE: THE PLAN HEREIN IS A FINAL ENGINEERING DOCUMENT. IT IS THE RESPONSIBILITY OF THE ENGINEER TO PROVIDE ALL NECESSARY INFORMATION TO THE CONTRACTOR. A COPY MAY BE OBTAINED UPON REQUEST.

| MAILBOX & PLATFORM DIMENSIONS | | | | |
|-------------------------------|-----|---------|---------|-----|
| SIZE | L | W | H | H |
| 1 | 19" | 6 1/2" | 8 1/2" | 17" |
| 1A | 21" | 8" | 10 1/2" | 18" |
| 2 | 24" | 11 1/2" | 13 1/2" | 21" |

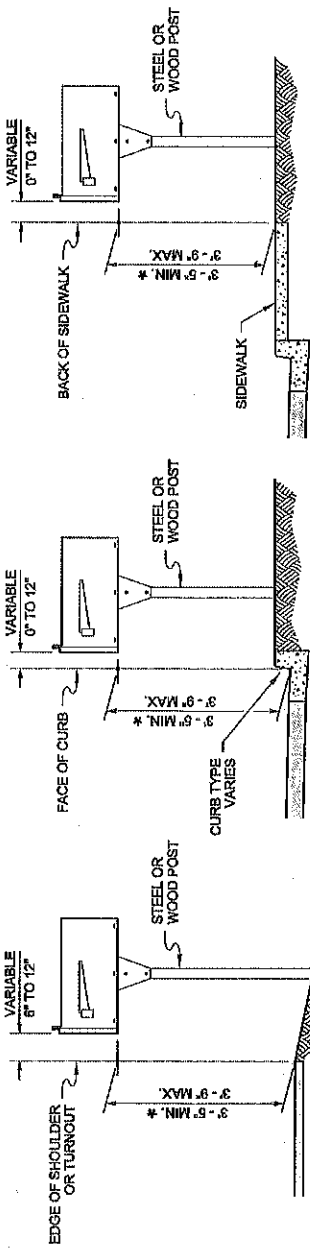

MAILBOX PLACEMENT SECTIONS
* UNLESS OTHERWISE SHOWN IN THE PLANS

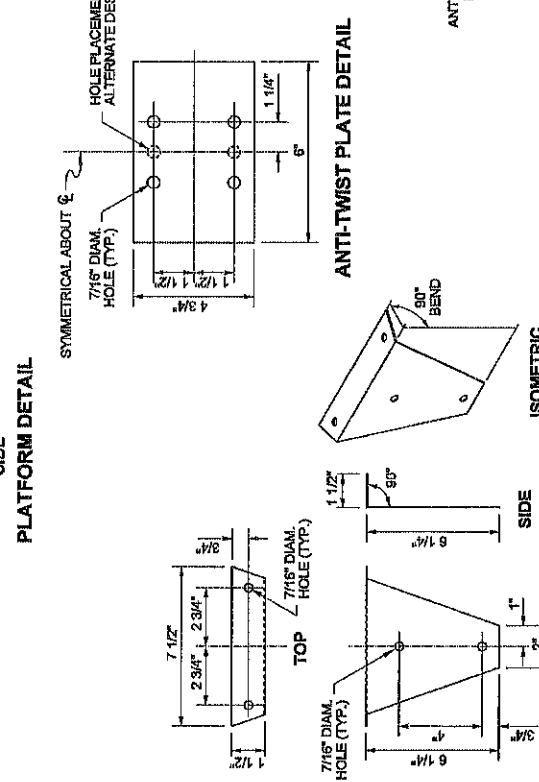
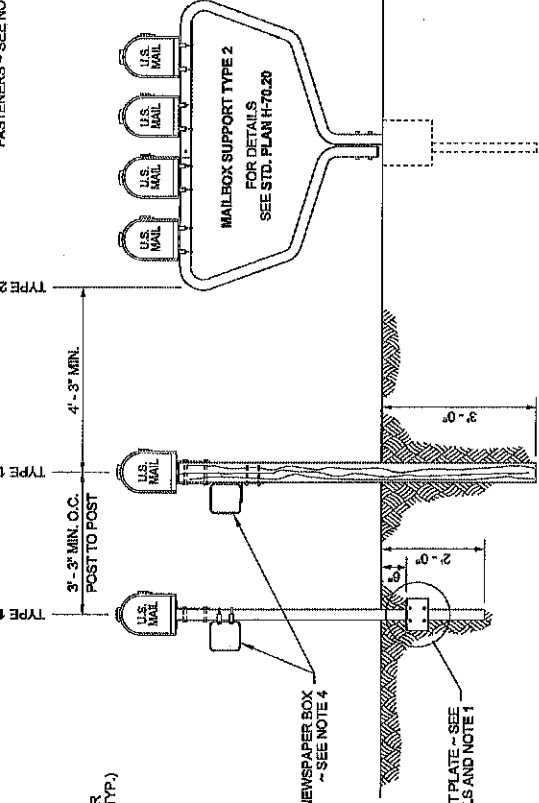
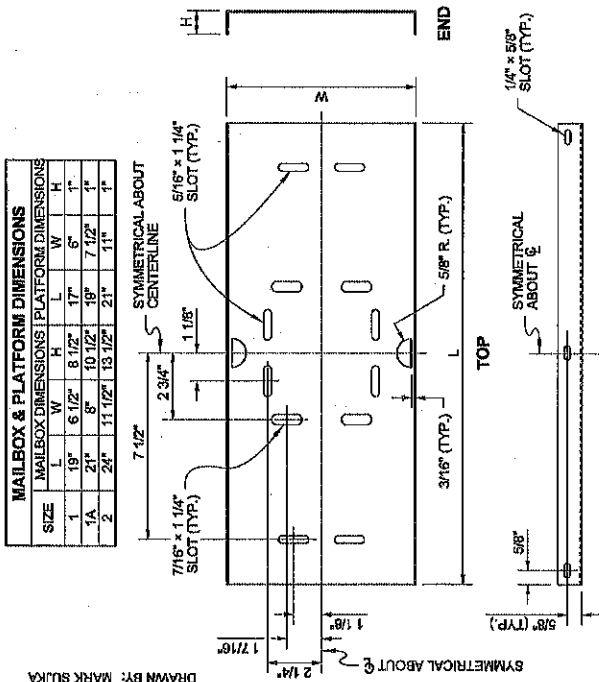

POST PLACEMENT DETAIL

BRACKET DETAIL

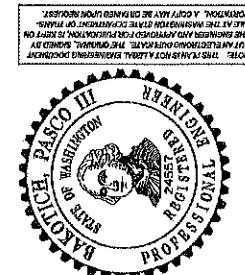

MAILBOX SUPPORT TYPE 1
STANDARD PLAN H-70.10-01

SHEET 2 OF 2 SHEETS
APPROVED FOR PUBLICATION
Pasco Bakofich III
STATE ENGINEER
DATE **02-07-12**
Washington State Department of Transportation

NOTE: THIS PLAN IS NOT A LEGAL ENGINEERING DOCUMENT. THE ENGINEER HAS APPROVED FOR PUBLICATION, BUT IS NOT PROVIDING ANY GUARANTEE OR WARRANTY. A COPY MAY BE OBTAINED FROM THE ENGINEER'S OFFICE.

DRAWN BY: MARK SUJKA

NOTES

1. Size the Below Inlet Grate Device (BIGD) for the storm water structure it will service.
2. The BIGD shall have a built-in high-flow relief system (overflow bypass).
3. The retrieval system must allow removal of the BIGD without spilling the collected material.
4. Perform maintenance in accordance with Standard Specification 8-01.3(15).

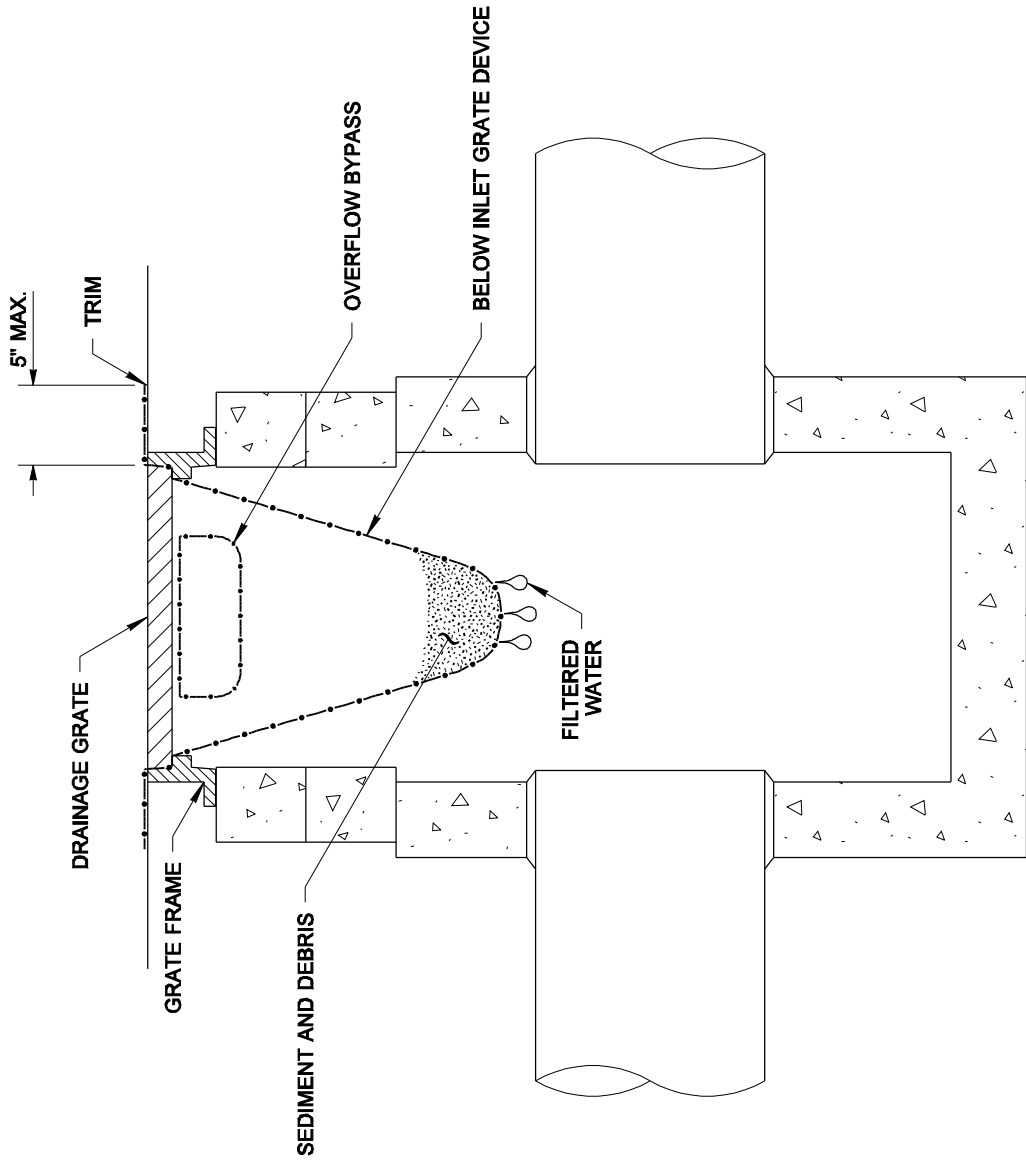

SECTION VIEW
NOT TO SCALE

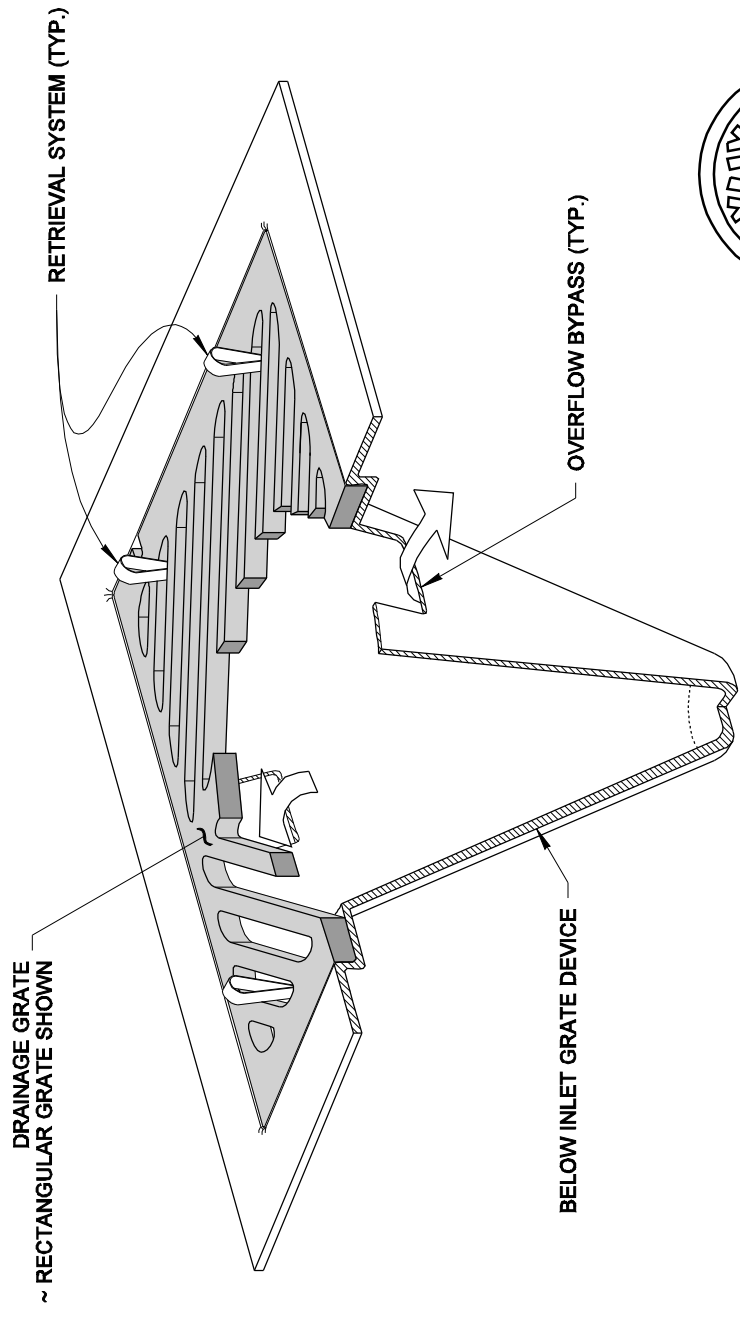

ISOMETRIC VIEW

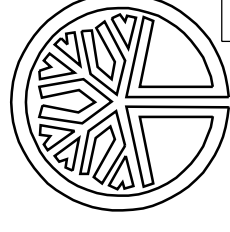

STATE OF WASHINGTON REGISTERED LANDSCAPE ARCHITECT

MARK W. MAURER
CERTIFICATE NO. 000598

NOTE: THIS PLAN IS NOT A LEGAL ENGINEERING DOCUMENT BUT AN ELECTRONIC DUPLICATE. THE ORIGINAL, SIGNED BY THE ENGINEER AND APPROVED FOR PUBLICATION, IS KEPT ON FILE AT THE WASHINGTON STATE DEPARTMENT OF TRANSPORTATION. A COPY MAY BE OBTAINED UPON REQUEST.

**STORM DRAIN
INLET PROTECTION
STANDARD PLAN I-40.20-00**

SHEET 1 OF 1 SHEET

APPROVED FOR PUBLICATION

Pasco Bakotich III 09-20-07
STATE DESIGN ENGINEER DATE

Washington State Department of Transportation

GENERAL NOTE

See Standard Plan M-20.10 for pattern and color requirements.

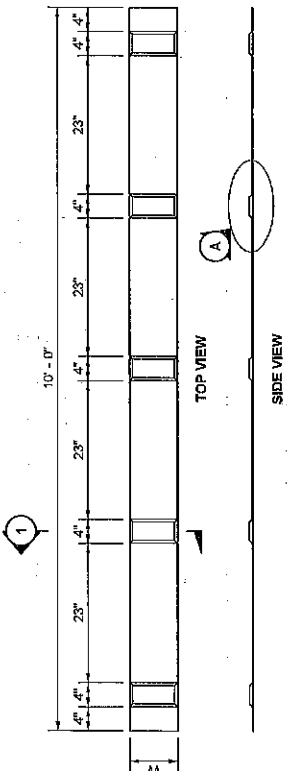
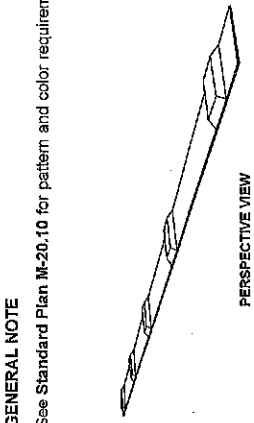
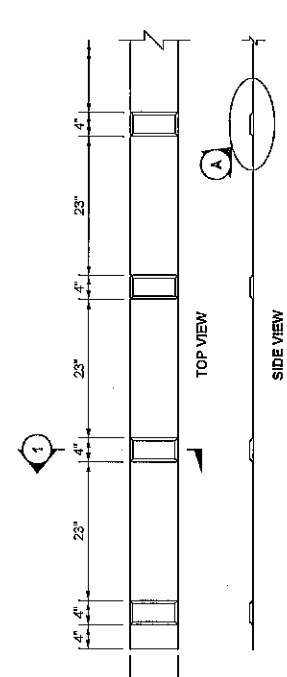

PROFILLED PLASTIC (SOLID LINE)
 FOR:
 NO-PASS LINE - W = 4"
 TWO-WAY LEFT-TURN CENTERLINE - W = 4"
 DOUBLE CENTERLINE & DOUBLE LANE LINE - W = 4"
 EDGE LINE & SOLID LANE LINE - W = 4"
 WIDE LANE LINE & WIDE LINE - W = 8"
 DOUBLE WIDE LANE LINE - W = 8"
 BARRIER CENTERLINE - W = 20"

PROFILLED PLASTIC (BROKEN LINE)
 FOR:
 CENTERLINE & LANE LINE - W = 4"
 NO-PASS LINE & TWO-WAY LEFT-TURN CENTERLINE - W = 4"
 REVERSIBLE LANE LINE - W = 4"
 WIDE BROKEN LANE LINE - W = 8"

EMBOSSSED PLASTIC (SOLID OR BROKEN LINE)
 FOR:
 CENTERLINE & LANE LINE
 NO-PASS LINE & TWO-WAY LEFT-TURN CENTERLINE
 DOUBLE CENTERLINE & DOUBLE LANE LINE
 EDGE LINE & SOLID LANE LINE

PROFILLED PLASTIC (BROKEN LINE)
 FOR:
 DOTTED EXTENSION LINE
 DOTTED LANE LINE - W = 4"
 WIDE DOTTED LANE LINE - W = 8"

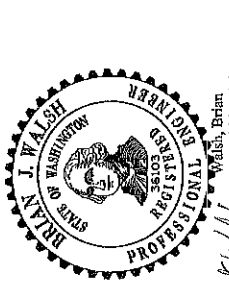
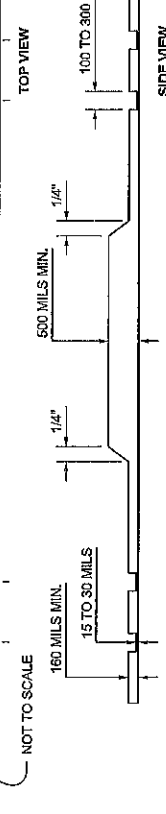
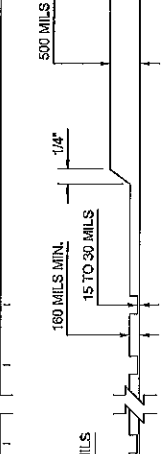
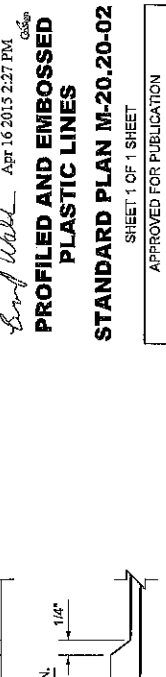
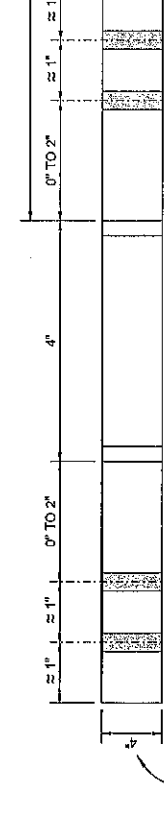
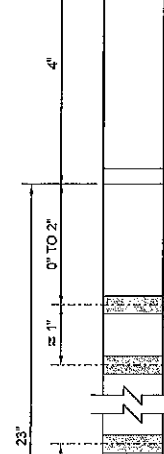
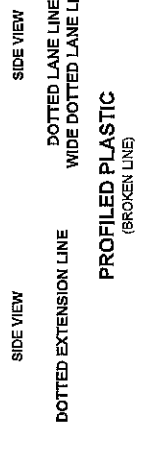
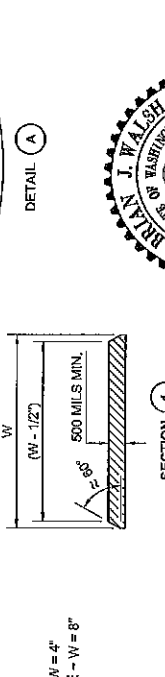
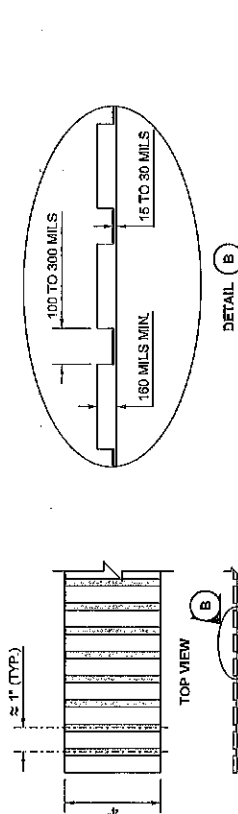
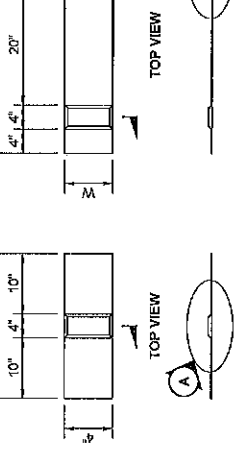
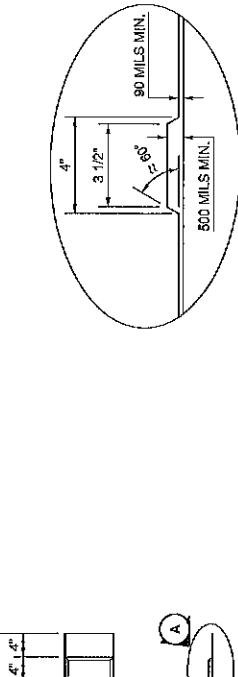

Brian Walsh
 Brian Walsh, P.E.
 Washington State Department of Transportation
 Apr 16 2015 2:27 PM
PROFILLED AND EMBOSSSED PLASTIC LINES
STANDARD PLAN M-20.20-02
 SHEET 1 OF 1 SHEET

APPROVED FOR PUBLICATION
R. B. Fletcher
 R. B. Fletcher, P.E.
 STATE ENGINEER
 Washington State Department of Transportation
 Apr 20 2015 10:07 AM

PROFILLED EMBOSSSED PLASTIC (SOLID OR BROKEN LINE)
 FOR:
 CENTERLINE & LANE LINE
 NO-PASS LINE
 TWO-WAY LEFT-TURN CENTERLINE
 REVERSIBLE LANE LINE
 DOUBLE CENTERLINE & DOUBLE LANE LINE
 EDGE LINE & SOLID LANE LINE

NOTE
Use the dimensions shown on this plan for each type of Traffic Arrow being placed on roadways with a posted speed limit of 40 mph or lower.

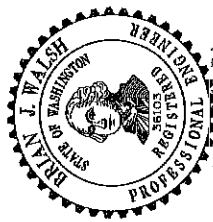
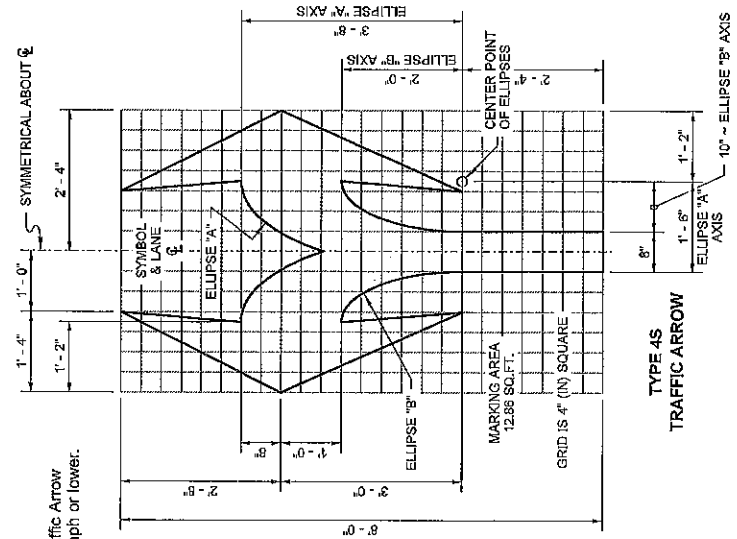

Brian J. Walsh
Washish, Brian
Apr 16 2015 2:21 PM
Case#
SYMBOL MARKINGS FOR TRAFFIC ARROWS FOR LOW-SPEED ROADWAYS
STANDARD PLAN M-24.40-02

SHEET 1 OF 2 SHEETS

APPROVED FOR PUBLICATION
Bainbridge, Tesco
Apr 20 2015 10:11 AM

Russell B. Fletcher
STATE DESIGN ENGINEER

Washington State Department of Transportation

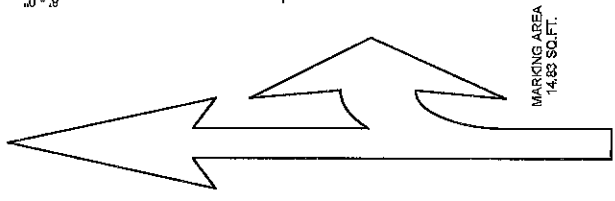

TYPE 3SR (RIGHT) TRAFFIC ARROW
MIRROR IMAGE OF TYPE 3SL TRAFFIC ARROW (SHOWN AT REDUCED SCALE)

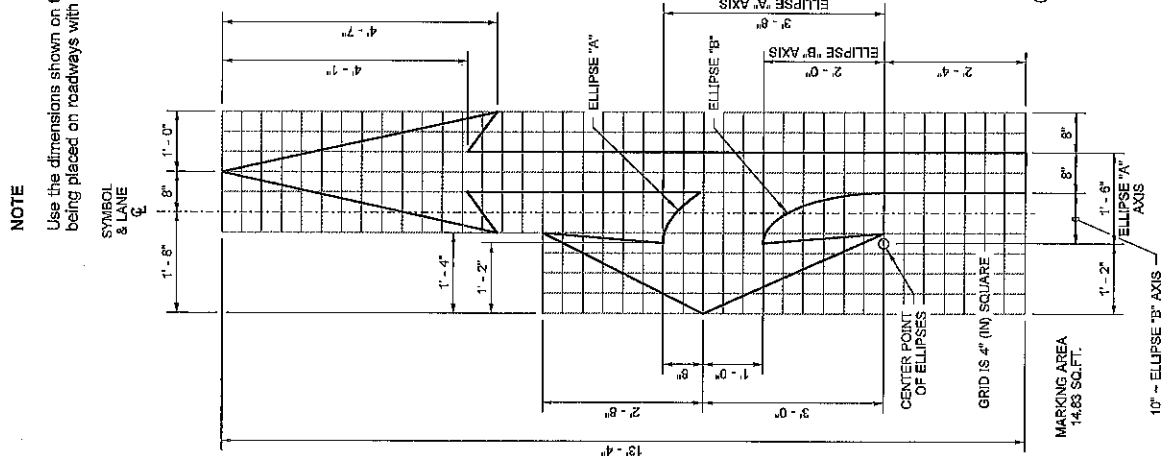

TYPE 3SL (LEFT) TRAFFIC ARROW



TYPE 2SR (RIGHT) TRAFFIC ARROW
MIRROR IMAGE OF TYPE 2SL TRAFFIC ARROW (SHOWN AT REDUCED SCALE)

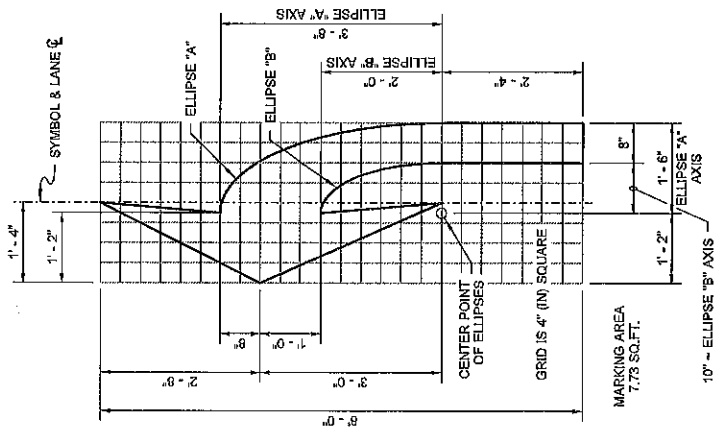

TYPE 2SL (LEFT) TRAFFIC ARROW

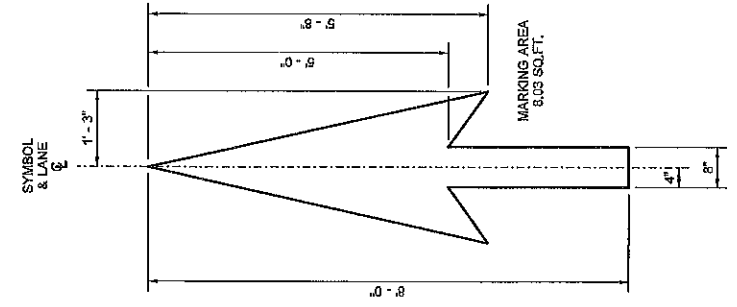

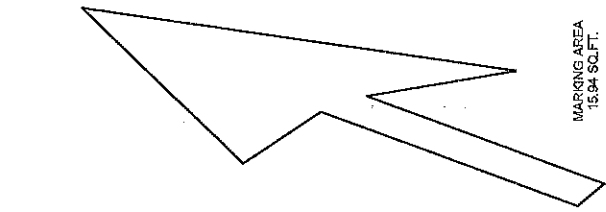

MARKING AREA
15.94 SQ.FT.

**TYPE 6SR (RIGHT)
TRAFFIC ARROW**

MIRROR IMAGE OF TYPE 6SL
(MIRRORED ABOUT LANE CENTERLINE)
(SHOWN AT REDUCED SCALE)



Brian J. Walsh
 Brian J. Walsh, P.E.
 APR 16 2015 2:21 PM
**SYMBOL MARKINGS ~
 TRAFFIC ARROWS FOR
 LOW-SPEED ROADWAYS
 STANDARD PLAN M-24-40-02**

SHEET 2 OF 2 SHEETS

APPROVED FOR PUBLICATION

Shelley Davis
 APR 20 2015 10:11 AM

STATE DESIGN ENGINEER



Washington State Department of Transportation

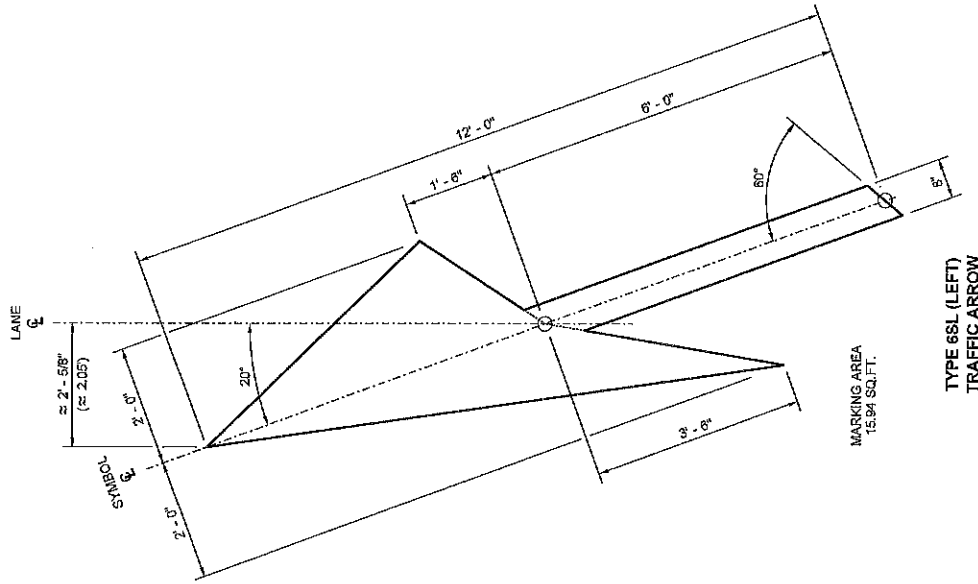

MARKING AREA
15.94 SQ.FT.

**TYPE 6SL (LEFT)
TRAFFIC ARROW**

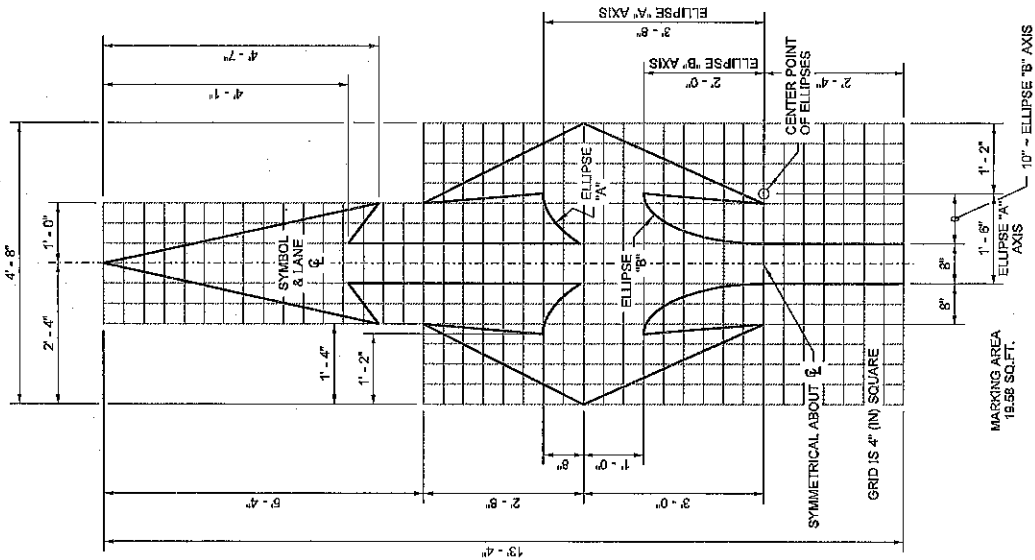

MARKING AREA
15.96 SQ.FT.

TYPE 75 TRAFFIC ARROW

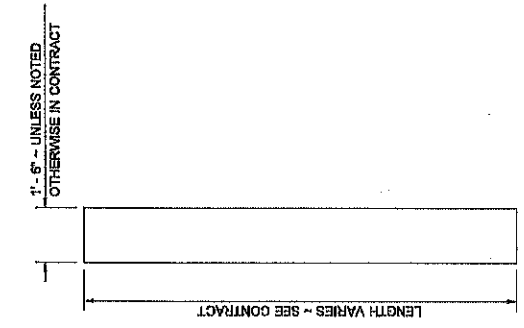

STOP LINE

WHITE OR YELLOW - SEE CONTRACT
CHEVRON OR DIAGONAL

CROSSHATCH MARKING

W = 8" (N) FOR POSTED SPEED LIMIT OF 40 MPH OR LOWER
W = 12" (N) FOR POSTED SPEED LIMIT OF 45 MPH OR HIGHER

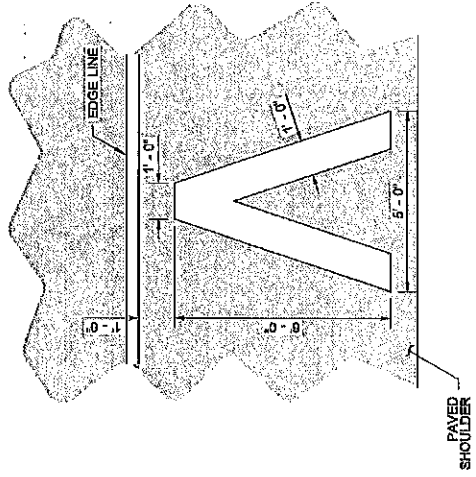

MARKING AREA = 11.75 SQ.FT.
HALF-MILE MARKER

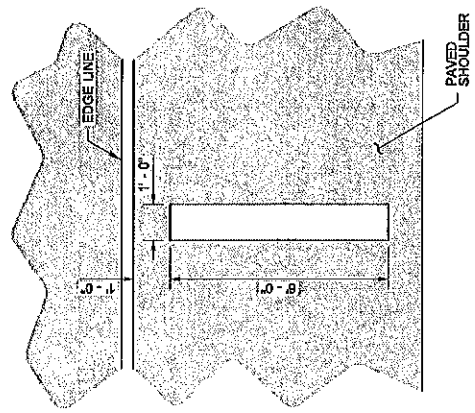

MARKING AREA = 6.00 SQ.FT.
FULL MILE MARKER

AERIAL SURVEILLANCE MARKERS

NOTE

1. If Rumble Strips are present, install marking outside of the Rumble Strip.

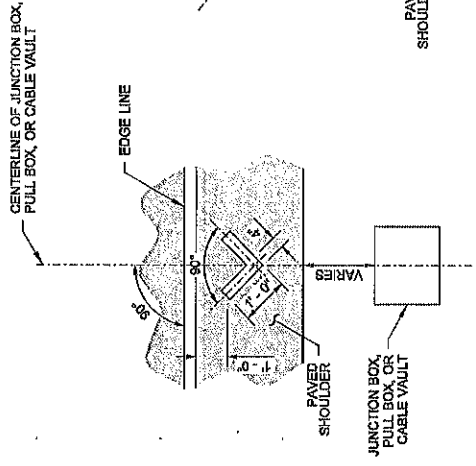

MARKING AREA = 0.96 SQ. FT.
JUNCTION BOX, PULL BOX, OR CABLE VAULT MARKINGS

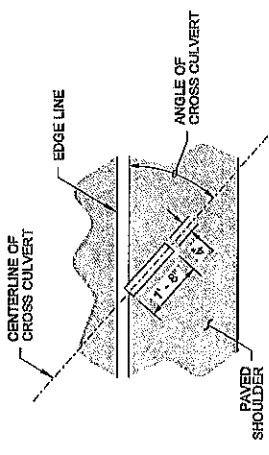

MARKING AREA = 0.66 SQ.FT.
CROSS CULVERT

DRAINAGE MARKING

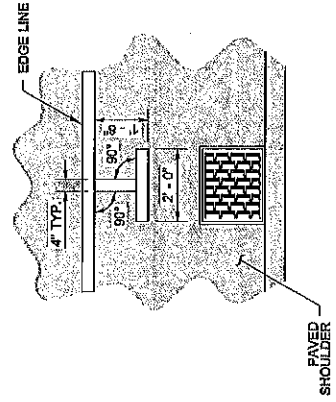

MARKING AREA = 1.08 SQ.FT.
DRAINAGE STRUCTURE INLET

DRAINAGE MARKING



Bryan J. Walsh
Walsh, Brian
Jun 24 2014 2:35 PM
C649

**SYMBOL MARKINGS
MISCELLANEOUS**

STANDARD PLAN M-24.60-04

SHEET 1 OF 2 SHEETS

APPROVED FOR PUBLICATION
Bellevue, Wa
Jun 24 2014 4:48 PM
STATE DESIGN ENGINEER
Washington State Department of Transportation

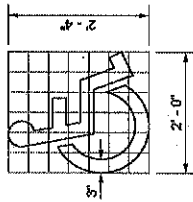

GRID IS 4" (IN) SQUARE MARKING AREA = 1.41 SQ.FT.
ACCESS PARKING SPACE SYMBOL
(MINIMUM)

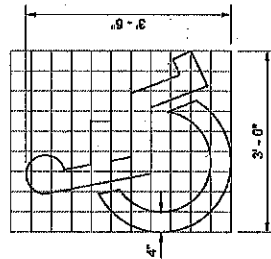

GRID IS 4" (IN) SQUARE MARKING AREA = 3.09 SQ.FT.
ACCESS PARKING SPACE SYMBOL
(STANDARD)

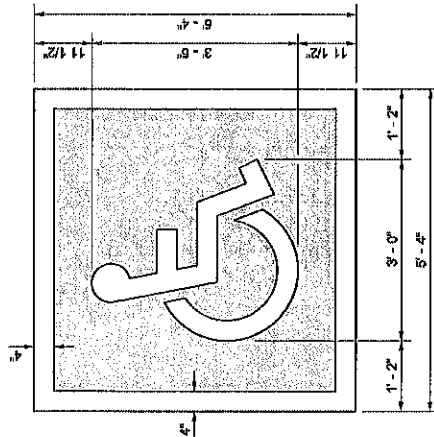

TOTAL MARKING AREA = 28.44 SQ.FT.
WHITE = 5.76 SQ.FT. BLUE = 16.59 SQ.FT.
ACCESS PARKING SPACE SYMBOL (STANDARD)
WITH BLUE BACKGROUND AND WHITE BORDER
(REQUIRED FOR CEMENT CONCRETE SURFACES)

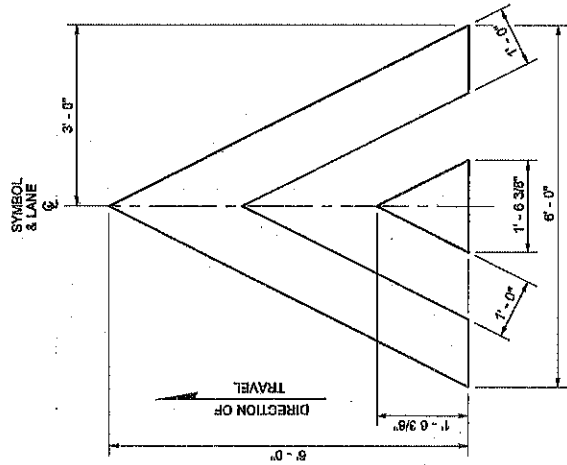

MARKING AREA = 12.09 SQ.FT.
SPEED BUMP SYMBOL

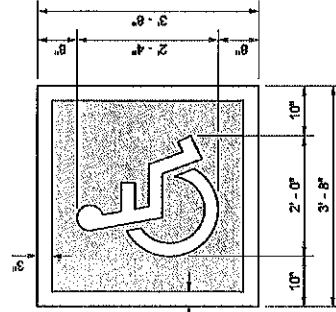

TOTAL MARKING AREA = 13.44 SQ.FT.
WHITE = 4.82 SQ.FT. BLUE = 6.62 SQ.FT.
ACCESS PARKING SPACE SYMBOL (MINIMUM)
WITH BLUE BACKGROUND AND WHITE BORDER
(REQUIRED FOR CEMENT CONCRETE SURFACES)

| SYMBOL MARKING | A | B | C | D | USE | MARKING AREA |
|--------------------|-------|-------|--------|-------|--------------------|--------------|
| | | | | | | |
| YIELD AHEAD SYMBOL | 6'-0" | 2'-6" | 13'-0" | N/A | LESS THAN 45 MPH | 25.90 SQ.FT. |
| | 6'-0" | 3'-0" | 20'-0" | N/A | 45 MPH OR GREATER | 36.54 SQ.FT. |
| YIELD LINE SYMBOL | 1'-0" | 6" | 1'-6" | 6" | LESS THAN 45 MPH | 0.76 SQ.FT. |
| | 2'-0" | 1'-0" | 3'-0" | 1'-0" | 45 MPH OR GREATER | 3.00 SQ.FT. |
| | 2'-0" | 1'-0" | 3'-0" | 1'-0" | ROUNDABOUT ENTRY * | 3.00 SQ.FT. |
| | 2'-0" | 1'-0" | 3'-0" | 1'-0" | ROUNDABOUT ENTRY * | 3.00 SQ.FT. |

* MINIMUM OF 4 IN LANE

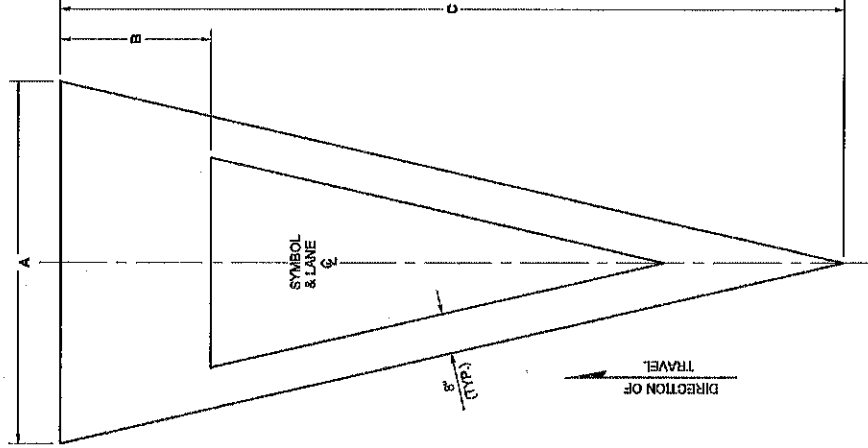

YIELD AHEAD SYMBOL

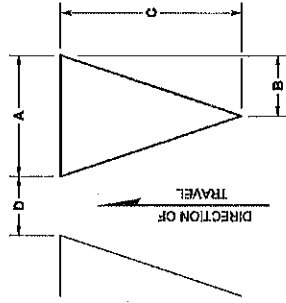

YIELD LINE SYMBOL
(MULTIPLE SYMBOLS REQUIRED
FOR TRANSVERSE YIELD LINE -
SEE CONTRACT)



Prof. Bill Walsh, P.E.
Jun 24, 2014 2:37 PM
Case #

**SYMBOL MARKINGS
MISCELLANEOUS**

STANDARD PLAN M-24-60-04

SHEET 2 OF 2 SHEETS

APPROVED FOR PUBLICATION
Baltimore, Maryland
Jun 24, 2014 4:43 PM
R. B. B. B. B.
STATE RESORT ENGINEER
Washington State Department of Transportation

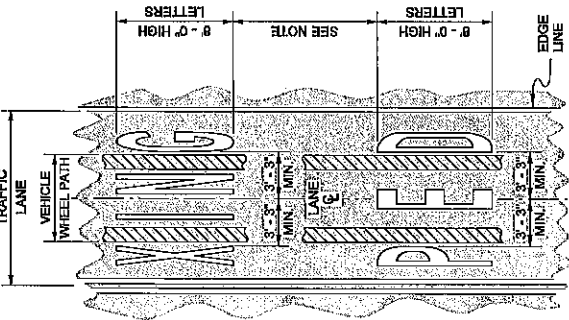

HIGH-SPEED APPLICATION

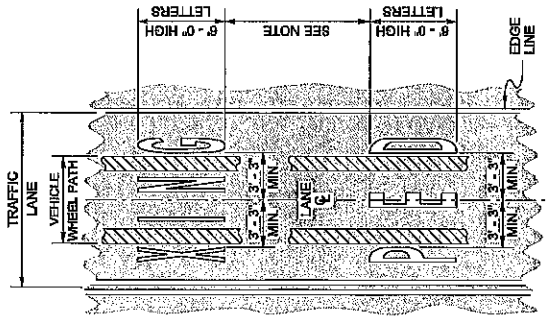

LOW-SPEED APPLICATION

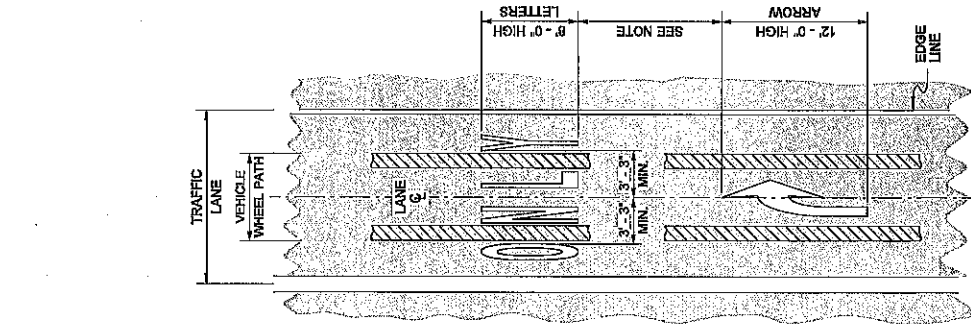

HIGH-SPEED APPLICATION

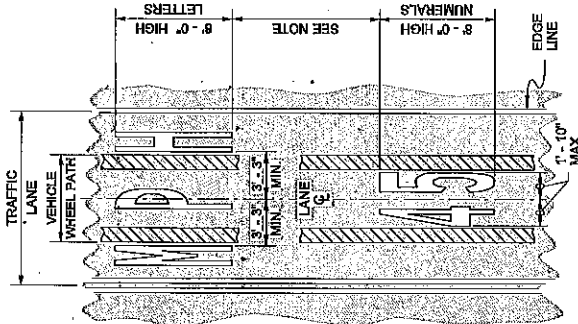

HIGH-SPEED APPLICATION

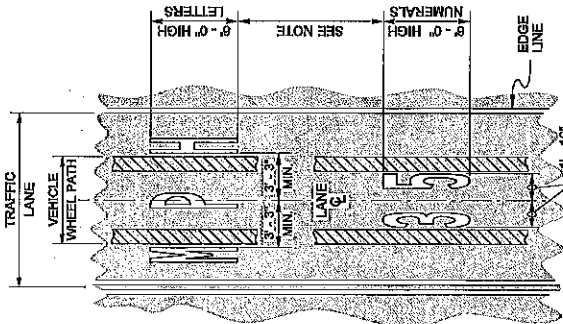

LOW-SPEED APPLICATION

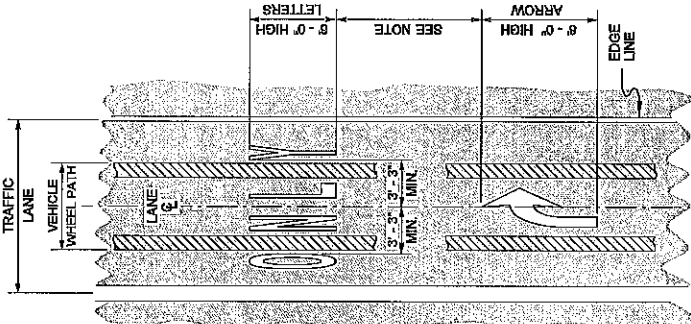

LOW-SPEED APPLICATION

NOTE

1. Typically, four times the letter or numeral height - minimum, up to ten times - maximum, or according to Plans.



NOTE: THIS PLAN IS NOT A LEGAL ENGINEERING DOCUMENT. IT IS THE ENGINEER'S RESPONSIBILITY TO CHECK ALL INFORMATION AND APPROVALS FOR THE PROJECT. A COPY MAY BE OBTAINED FROM THE ENGINEER. A COPY MAY BE OBTAINED FROM THE ENGINEER.

TRAFFIC LETTER AND NUMERAL APPLICATIONS
STANDARD PLAN M-80.10-01

SHEET 1 OF 2 SHEETS
 APPROVED FOR PUBLICATION
 Pasco Bakotich III
 STATE LICENSE ENGINEER
 DATE 06-03-11
 Washington State Department of Transportation

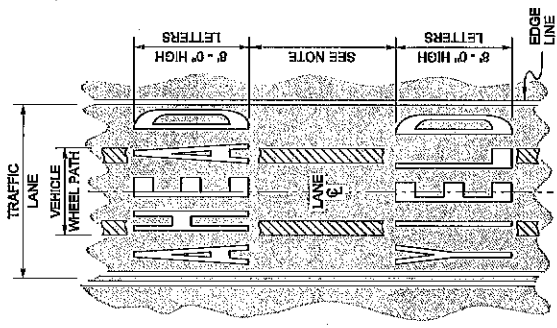

HIGH-SPEED APPLICATION

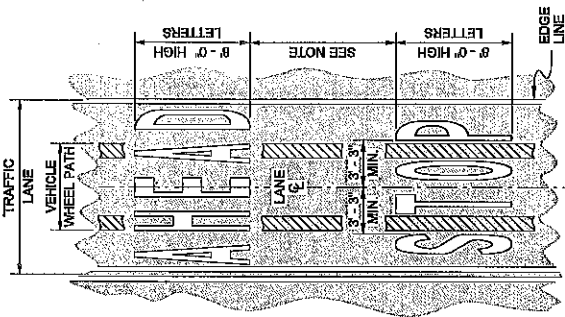

HIGH-SPEED APPLICATION

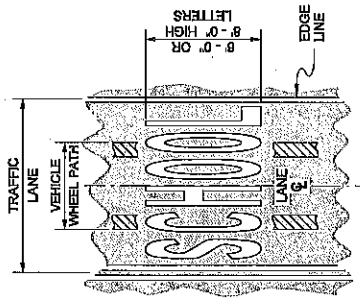

LOW-SPEED APPLICATION

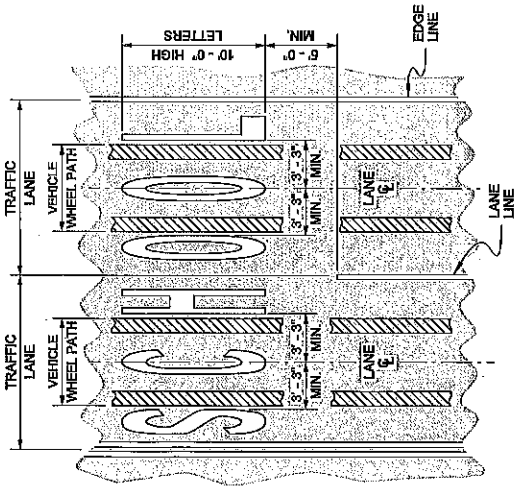

HIGH-SPEED APPLICATION

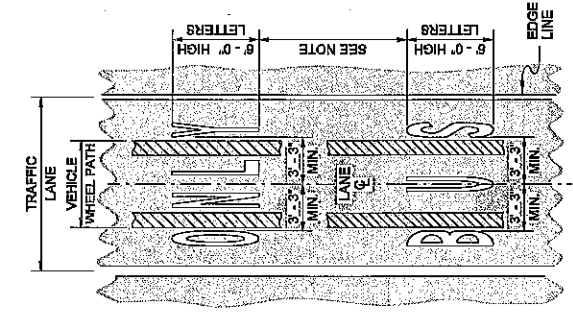

LOW-SPEED APPLICATION

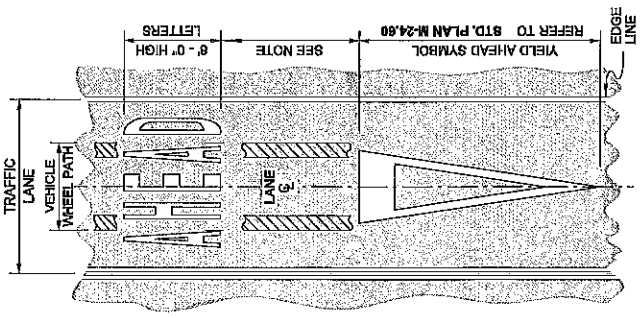

HIGH-SPEED APPLICATION

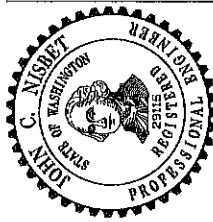

TRAFFIC LETTER AND NUMERAL APPLICATIONS
STANDARD PLAN M-80.10-01

SHEET 2 OF 2 SHEETS
 APPROVED FOR PUBLICATION
Pasco Bakofich III 06-03-11
 STATE DESIGN ENGINEER DATE
 Washington State Department of Transportation

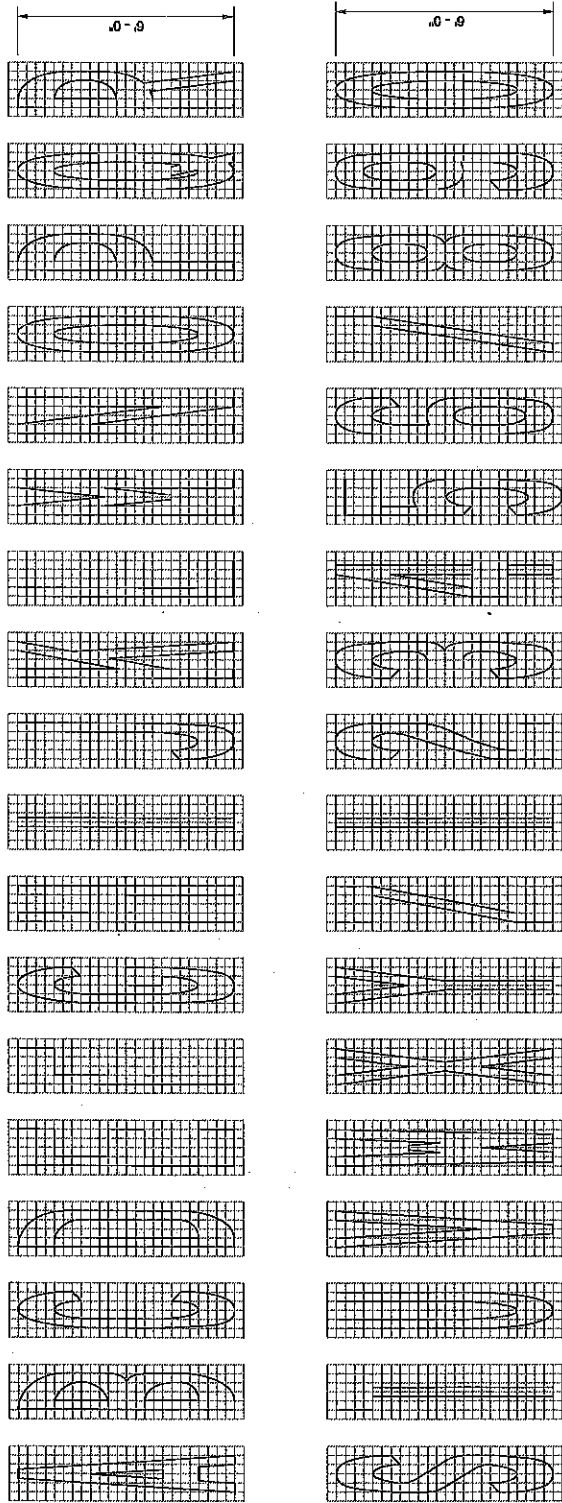

SIX FOOT HIGH LETTERS AND NUMERALS SHOWN ON A THREE-INCH SQUARE GRID

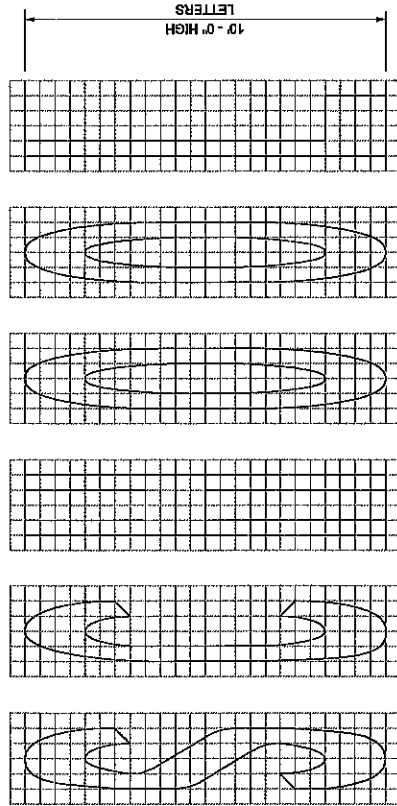

TEN FOOT HIGH LETTERS SHOWN ON A FIVE-INCH SQUARE GRID

FOR USE ON ROADWAYS WITH A POSTED SPEED OF 40 MPH OR LESS

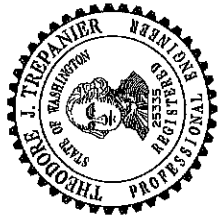

EXPIRES AUGUST 9, 2009

**TRAFFIC LETTERS AND NUMERALS
(LOW SPEED ROADWAYS)
STANDARD PLAN M-80-30-00**

SHEET 1 OF 1 SHEET

APPROVED FOR PUBLICATION

Pasco Bakofich III 06-10-08

STATE DESIGN ENGINEER DATE

Washington State Department of Transportation



NOTE: THIS PLAN IS NOT A LEGAL ENGINEERING DOCUMENT
 THE ENGINEER ASSUMES RESPONSIBILITY FOR THE CORRECTNESS OF THE DESIGN, INCLUDING
 ALL DETAILS, MATERIALS, AND CONSTRUCTION METHODS.
 FILE AT THE WASHINGTON STATE DEPARTMENT OF TRANSPORTATION
 FOR FURTHER INFORMATION CONTACT THE ENGINEER AT THE ADDRESS ABOVE.

TufTile® INSTALLATION INSTRUCTIONS SURFACE-APPLIED (REPLACEABLE)

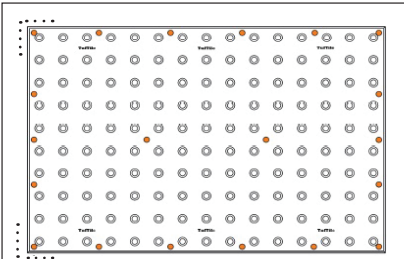

Fig. 1

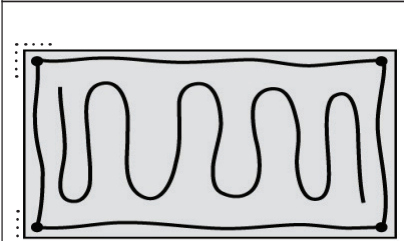

Fig. 2

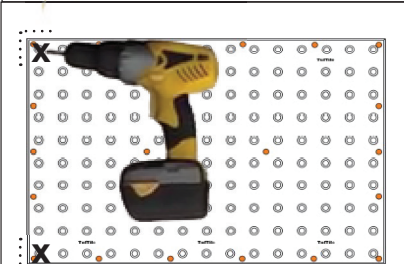

Fig. 3

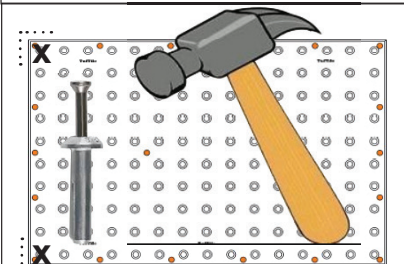
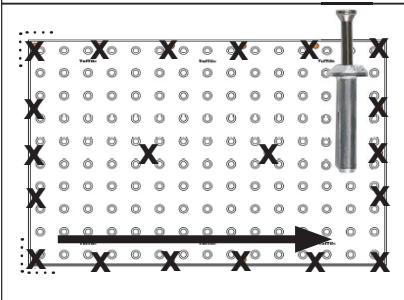

Fig. 4



Drive Pin Fastener



1. Read these instructions thoroughly before you begin. Consult the Access-Board, PROWAG guidelines R208 & R305 for tile placement location before beginning. Go to www.TufTile.com for Federal compliance documents.
2. Concrete surface must be clean and free of dust, debris, oil, moisture, and all contaminants that can prevent proper sealant adhesion. A wire brush or concrete cup grinder or other mechanical device can be used to prepare the surface.
3. Place **TufTile SA** on the concrete specifically where it is to be installed and mark the concrete at two corners. **(Figure 1)** Remove the TufTile from the marked location.
4. Apply a bead of sealant supplied by **TufTile** to the concrete completely around the perimeter about 1/2" in from the edge and zigzag in the center area of the tile. **(Figure 2)**
Spread any excess sealant over the back of the tile.
Note: Use sealant according to the manufacturer's instructions.
5. Replace the panel onto the prepared concrete and drill 2" (miminum) deep holes through the spots in the panel at the marked corners. **(Figure 3)**
6. Insert Drive Pins into the holes and hammer them down. **(Figure 4)**
7. Moving across the panel, (→) drill holes in all the provided locations in the panel and insert Drive Pins in each. Hammer the pins as you go. **(Figure 5)**

Your **TufTile** installation is now complete.

Additional installation information including an installation tutorial is available at

www.TufTile.com

If you have any additional questions please contact **TufTile®**

Thank you for your business!

1-888-960-8897

www.TufTile.com

| BUFFER DATA | | | | | | | | | | |
|--|-----|-----|-----|-----|-----|-----|-----|--------------------------------------|-----|----|
| LONGITUDINAL BUFFER SPACE = B | | | | | | | | | | |
| SPEED (MPH) | 25 | 30 | 35 | 40 | 45 | 50 | 55 | 60 | 65 | 70 |
| LENGTH (FEET) | 155 | 200 | 250 | 305 | 360 | 425 | 495 | 570 | 645 | - |
| BUFFER VEHICLE ROLL AHEAD DISTANCE = R | | | | | | | | | | |
| TRANSPORTABLE ATTENUATOR MINIMUM HOST VEHICLE WEIGHT 15,000 LBS. THE MAXIMUM WEIGHT SHALL BE IN ACCORDANCE WITH THE MANUFACTURERS RECOMMENDATION. | | | | | | | | 30 FEET MIN. TO 100 FEET MAX. | | |
| PROTECTIVE VEHICLE MAY BE A WORK VEHICLE STRATEGICALLY LOCATED TO SHIELD THE WORK AREA. | | | | | | | | NO SPECIFIED DISTANCE REQUIRED | | |

| SIGN SPACING = X (1) | | |
|---|----------------|------------|
| RURAL HIGHWAYS | 60 / 65 MPH | 600' ± |
| RURAL ROADS | 45 / 55 MPH | 500' ± |
| RURAL ROADS & URBAN ARTERIALS | 35 / 40 MPH | 350' ± |
| RURAL ROADS, URBAN ARTERIALS, RESIDENTIAL & BUSINESS DISTRICTS | 25 / 30 MPH | 200' ± (2) |
| URBAN STREETS | 25 MPH OR LESS | 100' ± (2) |
| (1) ALL SPACING MAY BE ADJUSTED TO ACCOMMODATE INTERSECTIONS AND DRIVEWAYS | | |
| (2) THIS SPACING MAY BE REDUCED IN URBAN AREAS TO FIT ROADWAY CONDITIONS. | | |

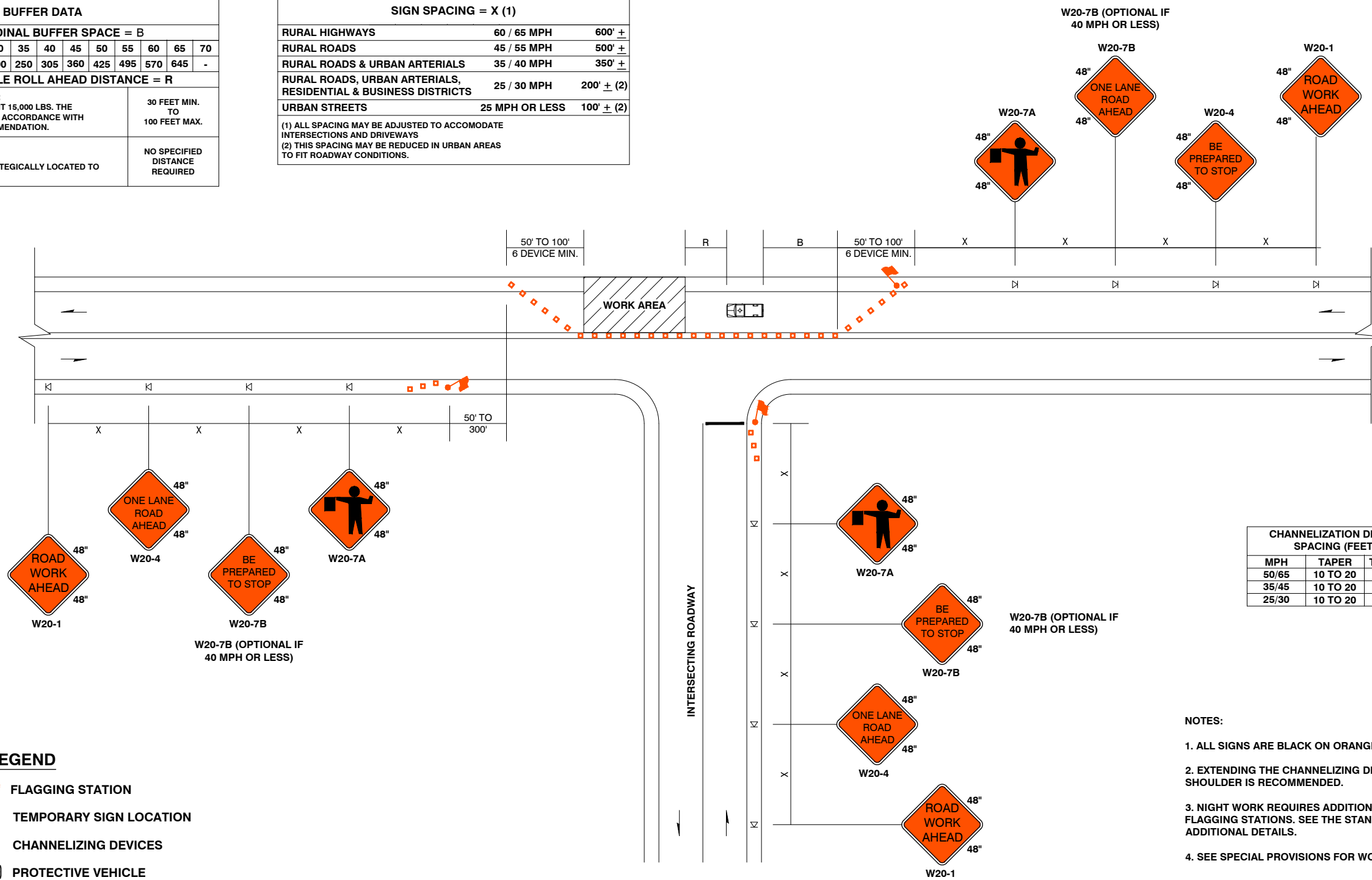

ONE-LANE, TWO WAY TRAFFIC CONTROL WITH FLAGGERS

NOT TO SCALE

| NO. | DATE | REVISION | BY | APP. |
|-----|------|----------|----|------|
| | | | | |
| | | | | |
| | | | | |

INTERSTATE AVENUE PAVING PROJECT

COUNTY ROAD PROJECT NO: 2187D

F.A. PROJECT: STPUS-HIPUS-5686(001)

F.A. CONTRACT NO.: TA-6614

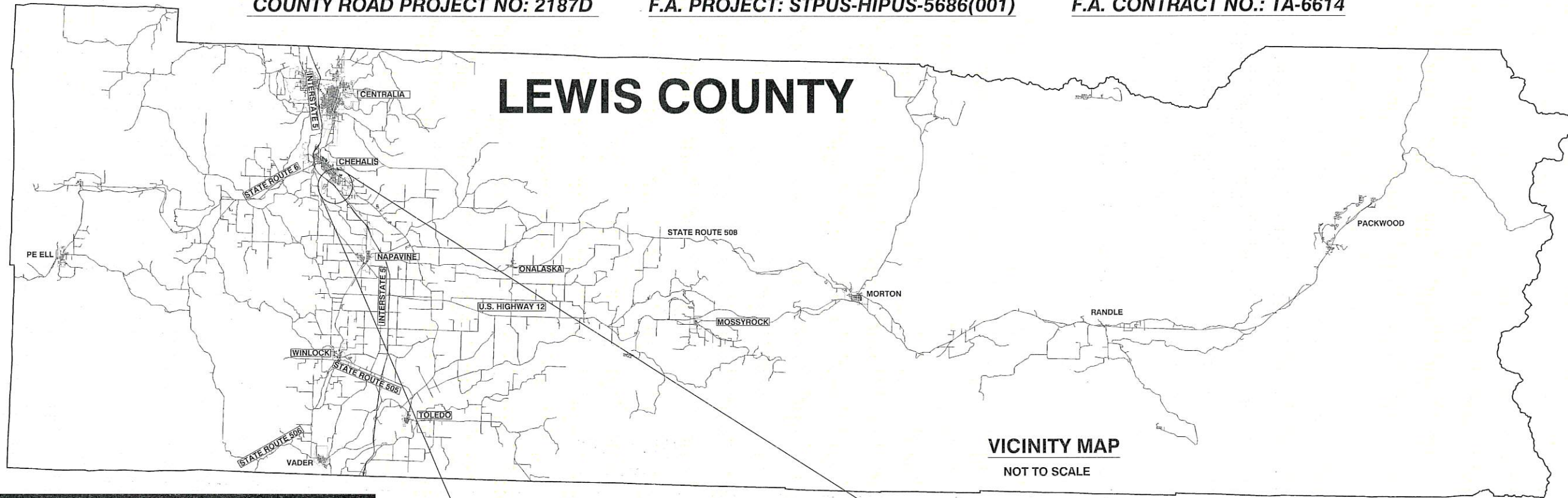

VICINITY MAP
NOT TO SCALE

LEWIS COUNTY
DEPARTMENT OF PUBLIC WORKS
APPROVED FOR CONSTRUCTION:

[Signature] 7-3-19
Assistant County Engineer Date

COMMISSIONERS:

- EDNA J. FUND, DISTRICT 1
- ROBERT C. JACKSON, DISTRICT 2
- GARY STAMPER, DISTRICT 3





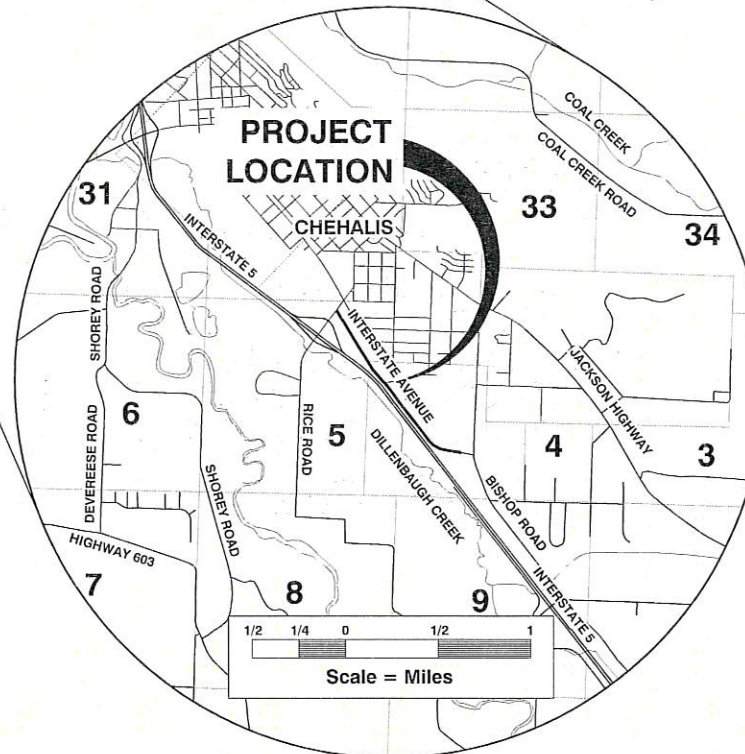



















ENGINEERING-
DESIGN SECTION



















| SHEET INDEX | |
|-------------|--|
| NO. | DESCRIPTION |
| 1 | VICINITY MAP AND SHEET INDEX |
| 2 | LEGEND |
| 3 | SUMMARY OF QUANTITIES |
| 4 | PLAN AND PROFILE STATION 0+20.32 TO STATION 10+50.00 |
| 5 | PLAN STATION 10+50.00 TO STATION 30+50.00 |
| 6 | PLAN STATION 30+50.00 TO STATION 51+90.00 |
| 7 | ROADWAY TYPICAL SECTION A, ROADWAY TYPICAL SECTION B |
| 8 | ROADWAY TYPICAL SECTION C, ROADWAY TYPICAL SECTION D |
| 9 | STRIPING STATION 0+00.00 TO STATION 5+25.00 |
| 10 | STRIPING STATION 5+25.00 TO STATION 25+25.00 |
| 11 | STRIPING STATION 25+25.00 TO STATION 46+25.00 |
| 12 | STRIPING STATION 46+25.00 TO STATION 51+90.00 |
| 13 | CONSTRUCTION SIGNS CLASS A |
| 14 | CONSTRUCTION SIGNS CLASS A |
| 15 | SUPPLEMENT TRAFFIC CONTROL PLAN |









LEGEND

EXISTING FEATURES









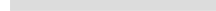

-  TELEPHONE RISER
-  TELEPHONE VAULT
-  POWER METER
-  POWER JUNCTION BOX
-  POWER VAULT
-  GAS VALVE
-  FENCE POST
-  FIRE HYDRANT
-  WATER VALVE
-  WELL HEAD
-  CENTERLINE CASE MONUMENT
-  STORM CATCH BASIN
-  SANITARY SEWER MANHOLE
-  SANITARY SEWER MANHOLE
-  SANITARY SEWER MANHOLE
-  BORE HOLE
-  MAG NAIL
-  FOUND REBAR WITH LS CAP
-  ALUMINUM CAP
-  REBAR LC
-  SIGN
-  TRAFFIC LOOP
-  TRAFFIC LOOP

-  WATER
-  UNDERGROUND WATER
-  EXISTING CENTERLINE
-  EXISTING ROAD EDGE
-  EXISTING APPROACH
-  EXISTING ASPHALT
-  FENCE
-  CURB
-  UNDERGROUND UTILITIES
-  UNDERGROUND FIBER
-  SEWER
-  GATE
-  GUARDRAIL
-  CONCRETE
-  UNDERGROUND GAS
-  FLOW LINE
-  ROADWAY

SURVEY FEATURES

-  POINT OF CURVATURE
-  POINT OF INTERSECTION
-  POINT OF TANGENT
-  LEWIS COUNTY HUB & TACK
-  LEWIS COUNTY SPIKE
-  IRON PIPE
-  RIGHT OF WAY
-  RAILROAD
-  RAILROAD ROW

NEW CONSTRUCTION FEATURES

-  CALLOUT
-  ROADWAY DESIGN CENTERLINE
-  DESIGN ROADWAY FINISHED TOP
-  FLOW LINE
-  MILLING AREA
-  PAVEMENT REPAIR
-  TRAVEL LANES
-  DETECTABLE WARNING SURFACE
-  CROSSWALK
-  2SL ARROW
-  2SR ARROW
-  PLASTIC TRAFFIC LETTER



2025 N. E. KRESKY AVE.
CHEHALIS WA 98532
PHONE # (360) 740-1123
FAX # (360) 740-2719

DESIGNED BY : DJC
DRAWN BY : KLC
CHECKED BY :
DATE :

| NO. | DATE | REVISION | BY | APP. |
|-----|------|----------|----|------|
| | | | | |
| | | | | |
| | | | | |
| | | | | |
| | | | | |

INTERSTATE AVENUE PAVING PROJECT

F.A. PROJECT: STPUS-HIPUS-5686(001)
COUNTY ROAD PROJECT NO: 2187D

LEGEND

SHEET
2 OF 15



CALL 48 HOURS BEFORE YOU DIG
1-800-424-5555
"It's the Law"
Utilizes Underground Location Center

Donald J Carney, P.E.
Senior Engineer Design
Date: 6/27/19



5/23/21

| SUMMARY OF QUANTITIES | | | | |
|--|---------------|---|----------------|----------|
| ITEM NO. | STD. ITEM NO. | ITEM DESCRIPTION | TOTAL QUANTITY | UNIT |
| PREPARATION | | | | |
| 1 | 0001 | MOBILIZATION | LUMP SUM | LUMP SUM |
| 2 | 0035 | CLEARING AND GRUBBING | LUMP SUM | LUMP SUM |
| 3 | 0050 | REMOVAL OF STRUCTURES AND OBSTRUCTIONS | LUMP SUM | LUMP SUM |
| GRADING | | | | |
| 4 | 0332 | PAVEMENT REPAIR EXCAVATION INCLUDING HAUL | 3,620 | S.Y. |
| SURFACING | | | | |
| 5 | S.P. | SHOULDER FINISHING | 1.40 | MILE |
| LIQUID ASPHALT | | | | |
| 6 | 5340 | ASPHALT FOR FOG SEAL | 10 | TON |
| HOT MIX ASPHALT | | | | |
| 7 | 5711 | PLANING BITUMINOUS PAVEMENT | 7,905 | S.Y. |
| 8 | 5738 | HMA FOR PAVEMENT REPAIR CL. 3/8 IN. PG 58H-22 | 515 | TON |
| 9 | S.P. | HMA CL. 3/8 IN. PG 58H-22 FIBER REINFORCED | 3,300 | TON |
| 10 | 5872 | HMA FOR APPROACH CL. 3/8 IN. PG 58H-22 | 130 | TON |
| EROSION CONTROL AND ROADSIDE PLANTING | | | | |
| 11 | 6471 | INLET PROTECTION | 5 | EACH |
| TRAFFIC | | | | |
| 12 | 6807 | PLASTIC LINE | 20,430 | L.F. |
| 13 | 6828 | PLASTIC WIDE LANE LINE | 420 | L.F. |
| 14 | 6833 | PLASTIC TRAFFIC ARROW | 4 | EACH |
| 15 | 6857 | PLASTIC CROSSWALK LINE | 288 | S.F. |
| 16 | 6859 | PLASTIC STOP LINE | 18 | L.F. |
| 17 | 6871 | PLASTIC TRAFFIC LETTER | 9 | EACH |
| 18 | 6971 | PROJECT TEMPORARY TRAFFIC CONTROL | LUMP SUM | LUMP SUM |
| 19 | 6974 | TRAFFIC CONTROL SUPERVISOR | LUMP SUM | LUMP SUM |
| 20 | 6980 | FLAGGERS | 700 | HOURL |
| 21 | 6982 | CONSTRUCTION SIGNS CLASS A | 450 | S.F. |
| 22 | 6992 | OTHER TRAFFIC CONTROL LABOR | 110 | HOURL |
| OTHER ITEMS | | | | |
| 23 | 3080 | ADJUST MANHOLE | 1 | EACH |
| 24 | 6243 | ADJUST VALVE BOX | 11 | EACH |
| 25 | 7054 | DETECTABLE WARNING SURFACE | 56 | S.F. |
| 26 | 7490 | TRIMMING AND CLEANUP | LUMP SUM | LUMP SUM |
| 27 | 7562 | MAILBOX SUPPORT TYPE 1 | 3 | EACH |
| 28 | 7725 | REIMBURSEMENT FOR THIRD PARTY DAMAGE | EST. | DOLLAR |
| 29 | 7728 | MINOR CHANGE | CALC. | DOLLAR |



2025 N. E. KRESKY AVE.
CHEHALIS WA 98532
PHONE # (360) 740-1123
FAX # (360) 740-2719

DESIGNED BY : DJC
DRAWN BY : J. PIPER
CHECKED BY :
DATE :

| NO. | DATE | REVISION | BY | APP. |
|-----|------|----------|----|------|
| | | | | |
| | | | | |
| | | | | |
| | | | | |

**INTERSTATE AVENUE
PAVING PROJECT**

F.A. PROJECT: STPUS-HIPUS-5686(001)
COUNTY ROAD PROJECT NO: 2187D

SUMMARY OF QUANTITIES

SHEET
3
OF
15



Donald J Carney, P.E.
Senior Engineer Design
Donald J Carney
Date: 6/27/19



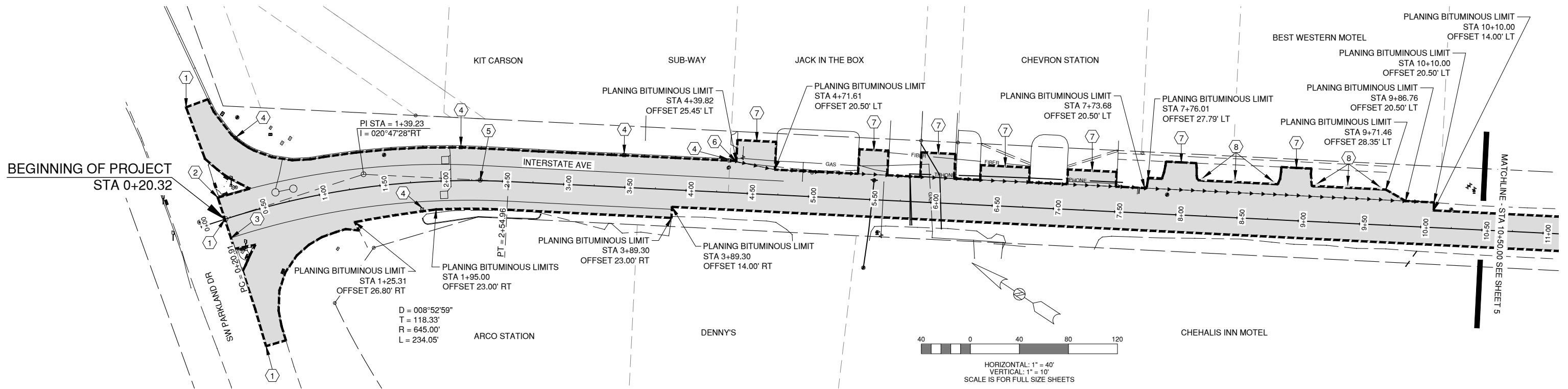

- CONSTRUCTION NOTES**
- 1 STA 0+20.32 TO STA 15+00.00
CONSTRUCT PLANING BITUMINOUS PAVEMENT AND PAVE INTERSTATE AVE TO BE STAKED IN THE FIELD BY THE ENGINEER
SEE ROADWAY TYPICAL SECTIONS A, B, & C ON SHEET 7 OF 15 & 8 OF 15
7220 S.Y. PLANING BITUMINOUS PAVEMENT
1000 TON HMA CL. 3/8 IN. PG 58H-22 FIBER REINFORCED
 - 2 STA 0+20.32, 18.57' LT TO 4+79.08, 11.50' LT
LEFT QUARTER CROWN
TO BE STAKED IN THE FIELD BY THE ENGINEER
SEE ROADWAY TYPICAL SECTION A ON SHEET 7 OF 15
 - 3 STA 0+20.32, 16.00' RT TO 3+89.30, 16.00' RT
RIGHT QUARTER CROWN
TO BE STAKED IN THE FIELD BY THE ENGINEER
SEE ROADWAY TYPICAL SECTION A ON SHEET 7 OF 15
 - 4 STA 0+46.45 TO STA 4+34.29
CONSTRUCT STORM DRAIN INLET PROTECTION
TO BE STAKED IN THE FIELD BY THE ENGINEER
SEE WSDOT STANDARD PLAN I-40.20-00
5 EACH INLET PROTECTION
 - 5 STA 0+00.00 TO STA 51+90.00
REMOVE ALL CENTERLINE MONUMENTS AND MONUMENT CASES
TO BE STAKED IN THE FIELD BY THE ENGINEER
INCLUDED IN BID ITEM REMOVAL OF STRUCTURES AND OBSTRUCTIONS
 - 6 STA 4+39.82 LEFT TO STA 10+10.00 LEFT
CONSTRUCT DRAINAGE FLOW LINE
TO BE STAKED IN THE FIELD BY THE ENGINEER
SEE ROADWAY TYPICAL SECTION B ON SHEET 7 OF 15
QUANTITIES ARE INCLUDED IN CONSTRUCTION NOTE 1 ON THIS SHEET
 - 7 STA 4+39.82 LEFT TO STA 9+10.66 LEFT
CONSTRUCT PLANING BITUMINOUS PAVEMENT AND PAVE APPROACHES
TO BE STAKED IN THE FIELD BY THE ENGINEER
PLANING BITUMINOUS PAVEMENT QUANTITIES ARE INCLUDED IN CONSTRUCTION NOTE 1 ON THIS SHEET
60 TON HMA FOR APPROACH CL. 3/8 IN. PG 58H-22
 - 8 STA 8+17.00 TO STA 9+70.00
RELOCATE PLANTER BOXES AS NEEDED
TO BE STAKED IN THE FIELD BY THE ENGINEER
INCLUDED IN BID ITEM REMOVAL OF STRUCTURES AND OBSTRUCTIONS

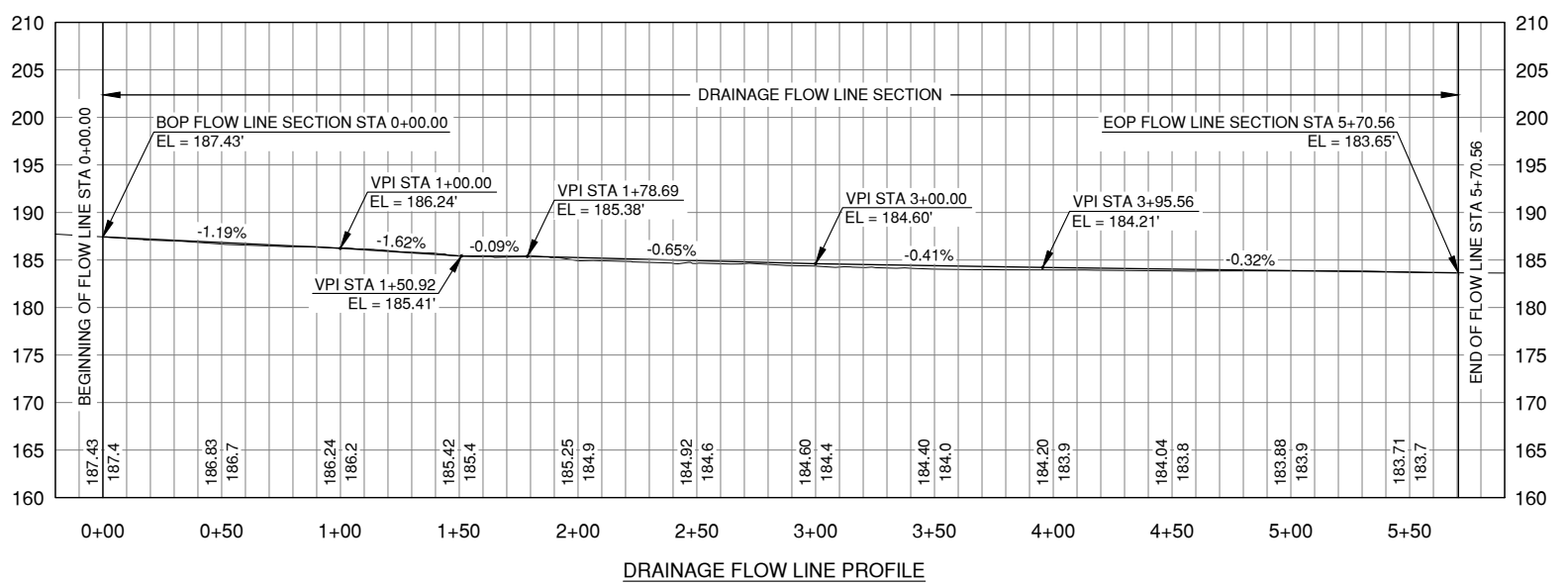

NOTE:
HAND WORK WILL BE REQUIRED AROUND CATCH BASINS, CURB, AND ISLANDS WHILE PLANING BITUMINOUS PAVEMENT AND PAVING.
REFERENCE LINE FOR VERTICAL CONTROL WILL BE NEEDED FOR DRAINAGE FLOW LINE.

Lewis County
Department of Public Works
2025 NE KRESKY AVE.
CHEHALIS WA 98532
PHONE # (360) 740-1123
FAX # (360) 740-1479

| | | | | |
|------------------|-----|------|----|------|
| DESIGNED BY :DJC | NO. | DATE | BY | APP. |
| DRAWN BY : CGA | | | | |
| CHECKED BY : | | | | |
| DATE : | | | | |

**INTERSTATE AVENUE
PAVING PROJECT**

F.A. PROJECT: STPUS-HIPUS-5686(001)
COUNTY ROAD PROJECT NO: 2187D
PLAN AND PROFILE
STATION 0+20.32 TO STATION 10+50.00

SHEET
4
OF
15

CALL 48 HOURS BEFORE YOU DIG
1-800-424-5555
"It's the Law"
Utilities
Underground
Location Center

Donald J Carney, P.E.
Senior Engineer Design
Date: 6/27/19



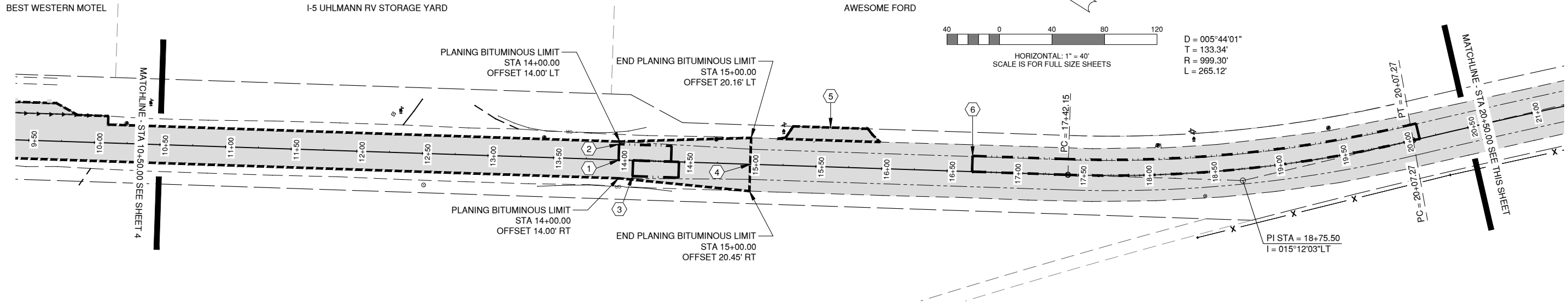

NOTE:
ALL RAISED PAVEMENT MARKERS AND LETTERING SHALL BE COMPLETELY REMOVED FROM EXISTING HMA SURFACE BEFORE TACK COAT AND NEW HMA IS TO BE PLACED

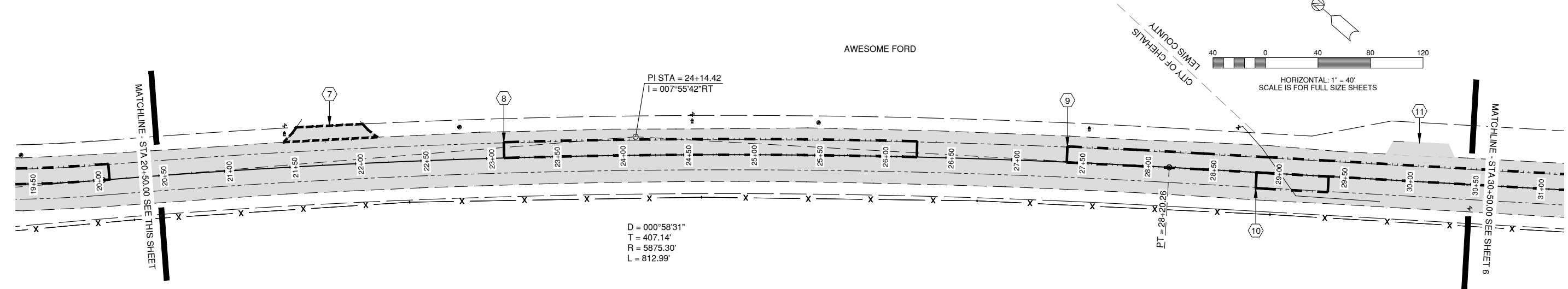

CONSTRUCTION NOTES

- 1 STA 14+00.00 TO STA 15+00.00
TRANSITION PAVING FROM 14.00' TRAVEL LANES AT STATION 14+00.00 TO 11.50' TRAVEL LANES AT STATION 15+00.00
TO BE STAKED IN THE FIELD BY THE ENGINEER
- 2 APPROXIMATE STA 13+99.64 LEFT TO APPROXIMATE STA 14+39.64 LEFT
BEGIN PAVEMENT REPAIR SECTION 12' WIDE X 40' LONG X 0.20' DEPTH
TO BE STAKED IN THE FIELD BY THE ENGINEER
55 S.Y. PAVEMENT REPAIR EXCAVATION INCL. HAUL
10 TON HMA FOR PAVEMENT REPAIR CL. 3/8 IN. PG 58H-22
- 3 APPROXIMATE STA 14+10.67 RIGHT TO APPROXIMATE STA 14+45.67 RIGHT
BEGIN PAVEMENT REPAIR SECTION 12' WIDE X 35' LONG X 0.20' DEPTH
TO BE STAKED IN THE FIELD BY THE ENGINEER
45 S.Y. PAVEMENT REPAIR EXCAVATION INCL. HAUL
5 TON HMA FOR PAVEMENT REPAIR CL. 3/8 IN. PG 58H-22

CONSTRUCTION NOTES

- 4 STA 15+00.00 TO STA 15+90.00
BEGIN OVERLAY TO REQUIRE 4 PASSES TWO 11.50' TRAVEL LANES AND TWO SHOULDERS TO EXISTING ASPHALT EDGE
SEE ROADWAY TYPICAL SECTION D ON SHEET 8 OF 15
2300 TON HMA CL. 3/8 IN. PG 58H-22 FIBER REINFORCED
- 5 STA 15+60.26 LEFT
CONSTRUCT PLANING BITUMINOUS PAVEMENT BUTT JOINT AND PAVE APPROACH
TO BE STAKED IN THE FIELD BY THE ENGINEER
70 S.Y. PLANING BITUMINOUS PAVEMENT
10 TON HMA FOR APPROACH CL. 3/8 IN. PG 58H-22
- 6 APPROXIMATE STA 16+69.09 LEFT TO APPROXIMATE STA 20+12.27 LEFT
BEGIN PAVEMENT REPAIR SECTION 12' WIDE X 340' LONG X 0.20' DEPTH
TO BE STAKED IN THE FIELD BY THE ENGINEER
455 S.Y. PAVEMENT REPAIR EXCAVATION INCL. HAUL
65 TON HMA FOR PAVEMENT REPAIR CL. 3/8 IN. PG 58H-22

CONSTRUCTION NOTES

- 7 STA 21+81.72 LEFT
CONSTRUCT PLANING BITUMINOUS PAVEMENT BUTT JOINT AND PAVE APPROACH
TO BE STAKED IN THE FIELD BY THE ENGINEER
70 S.Y. PLANING BITUMINOUS PAVEMENT
10 TON HMA FOR APPROACH CL. 3/8 IN. PG 58H-22
- 8 APPROXIMATE STA 23+13.46 LEFT TO APPROXIMATE STA 26+27.82 LEFT
BEGIN PAVEMENT REPAIR SECTION 12' WIDE X 315' LONG X 0.20' DEPTH
TO BE STAKED IN THE FIELD BY THE ENGINEER
420 S.Y. PAVEMENT REPAIR EXCAVATION INCL. HAUL
60 TON HMA FOR PAVEMENT REPAIR CL. 3/8 IN. PG 58H-22
- 9 APPROXIMATE STA 27+42.11 LEFT TO APPROXIMATE STA 31+41.95 LEFT
BEGIN PAVEMENT REPAIR SECTION 12' WIDE X 400' LONG X 0.20' DEPTH
TO BE STAKED IN THE FIELD BY THE ENGINEER
535 S.Y. PAVEMENT REPAIR EXCAVATION INCL. HAUL
75 TON HMA FOR PAVEMENT REPAIR CL. 3/8 IN. PG 58H-22

CONSTRUCTION NOTES

- 10 APPROXIMATE STA 28+86.96 RIGHT TO APPROXIMATE STA 29+41.96 RIGHT
BEGIN PAVEMENT REPAIR SECTION 12' WIDE X 55' LONG X 0.20' DEPTH
TO BE STAKED IN THE FIELD BY THE ENGINEER
75 S.Y. PAVEMENT REPAIR EXCAVATION INCL. HAUL
10 TON HMA FOR PAVEMENT REPAIR CL. 3/8 IN. PG 58H-22
- 11 STA 30+10.69 LEFT
PAVE APPROACH
TO BE STAKED IN THE FIELD BY THE ENGINEER
10 TON HMA FOR APPROACH CL. 3/8 IN. PG 58H-22

Lewis County
Department of Public Works
2025 NE KRESKY AVE.
CHEHALIS WA 98532
PHONE # (360) 740-1123
FAX # (360) 740-1479

DESIGNED BY :DJC
DRAWN BY : CGA
CHECKED BY :
DATE :

| NO. | DATE | BY | APP. |
|-----|------|----|------|
| | | | |
| | | | |
| | | | |

**INTERSTATE AVENUE
PAVING PROJECT**

F.A. PROJECT: STPUS-HIPUS-5686(001)
COUNTY ROAD PROJECT NO: 2187D

PLAN
STATION 10+50.00 TO STATION 30+50.00

SHEET
5
OF
15



Donald J Carney, P.E.
Senior Engineer Design
Date: 6/27/19



5/23/21

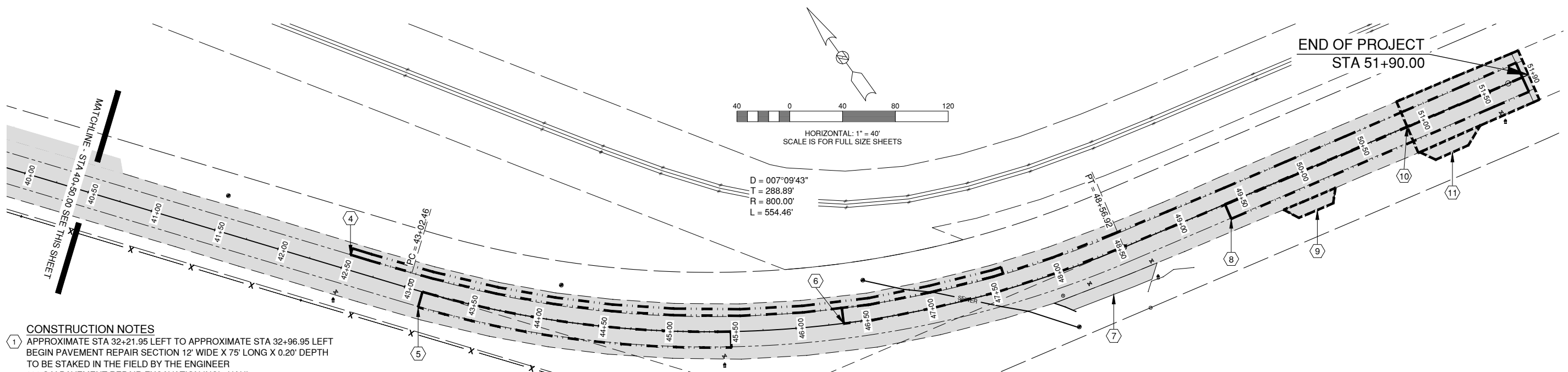
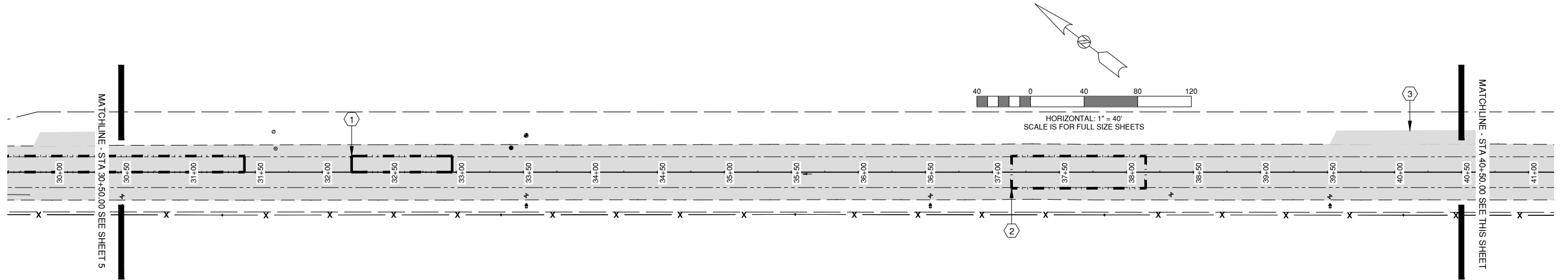

CONSTRUCTION NOTES

- 1 APPROXIMATE STA 32+21.95 LEFT TO APPROXIMATE STA 32+96.95 LEFT BEGIN PAVEMENT REPAIR SECTION 12' WIDE X 75' LONG X 0.20' DEPTH TO BE STAKED IN THE FIELD BY THE ENGINEER
100 S.Y PAVEMENT REPAIR EXCAVATION INCL. HAUL
15 TON HMA FOR PAVEMENT REPAIR CL. 3/8 IN. PG 58H-22
- 2 APPROXIMATE STA 37+14.39 TO APPROXIMATE STA 38+14.39 BEGIN PAVEMENT REPAIR SECTION 24' WIDE X 100' LONG X 0.20' DEPTH TO BE STAKED IN THE FIELD BY THE ENGINEER
270 S.Y PAVEMENT REPAIR EXCAVATION INCL. HAUL
40 TON HMA FOR PAVEMENT REPAIR CL. 3/8 IN. PG 58H-22
- 3 STA 40+11.56 LEFT
PAVE APPROACH
TO BE STAKED IN THE FIELD BY THE ENGINEER
20 TON HMA FOR APPROACH CL. 3/8 IN. PG 58H-22
- 4 APPROXIMATE STA 42+53.93 LEFT TO APPROXIMATE STA 47+63.26 LEFT BEGIN PAVEMENT REPAIR SECTION 5' WIDE X 500' LONG X 0.20' DEPTH TO BE STAKED IN THE FIELD BY THE ENGINEER
280 S.Y PAVEMENT REPAIR EXCAVATION INCL. HAUL
40 TON HMA FOR PAVEMENT REPAIR CL. 3/8 IN. PG 58H-22
- 5 APPROXIMATE STA 43+14.21 RIGHT TO APPROXIMATE STA 45+50.67 RIGHT BEGIN PAVEMENT REPAIR SECTION 12' WIDE X 238' LONG X 0.20' DEPTH TO BE STAKED IN THE FIELD BY THE ENGINEER
320 S.Y PAVEMENT REPAIR EXCAVATION INCL. HAUL
45 TON HMA FOR PAVEMENT REPAIR CL. 3/8 IN. PG 58H-22

CONSTRUCTION NOTES

- 6 APPROXIMATE STA 46+36.27 LEFT TO APPROXIMATE STA 51+84.87 LEFT BEGIN PAVEMENT REPAIR SECTION 12' WIDE X 545' LONG X 0.20' DEPTH TO BE STAKED IN THE FIELD BY THE ENGINEER
730 S.Y PAVEMENT REPAIR EXCAVATION INCL. HAUL
100 TON HMA FOR PAVEMENT REPAIR CL. 3/8 IN. PG 58H-22
- 7 STA 48+36.22 RIGHT
PAVE APPROACH
TO BE STAKED IN THE FIELD BY THE ENGINEER
10 TON HMA FOR APPROACH CL. 3/8 IN. PG 58H-22
- 8 APPROXIMATE STA 49+40.07 RIGHT TO APPROXIMATE STA 51+84.87 RIGHT BEGIN PAVEMENT REPAIR SECTION 12' WIDE X 245' LONG X 0.20' DEPTH TO BE STAKED IN THE FIELD BY THE ENGINEER
325 S.Y PAVEMENT REPAIR EXCAVATION INCL. HAUL
45 TON HMA FOR PAVEMENT REPAIR CL. 3/8 IN. PG 58H-22
- 9 STA 50+02.20
CONSTRUCT PLANING BITUMINOUS PAVEMENT BUTT JOINT AND PAVE APPROACH
TO BE STAKED IN THE FIELD BY THE ENGINEER
40 S.Y. PLANING BITUMINOUS PAVEMENT
5 TON HMA FOR APPROACH CL. 3/8 IN. PG 58H-22

CONSTRUCTION NOTES

- 10 STA 50+90.00 TO STA 51+90.00 RIGHT
CONSTRUCT PLANING BITUMINOUS PAVEMENT BUTT JOINT
TO BE STAKED IN THE FIELD BY THE ENGINEER
460 S.Y. PLANING BITUMINOUS PAVEMENT
- 11 STA 51+13.61 RIGHT
CONSTRUCT PLANING BITUMINOUS PAVEMENT BUTT JOINT AND PAVE APPROACH
TO BE STAKED IN THE FIELD BY THE ENGINEER
45 S.Y. PLANING BITUMINOUS PAVEMENT
5 TON HMA FOR APPROACH CL. 3/8 IN. PG 58H-22

2025 NE KRESKY AVE.
CHEHALIS WA 98532
PHONE # (360) 740-1123
FAX # (360) 740-1479

DESIGNED BY :DJC
DRAWN BY : CGA
CHECKED BY :
DATE :

| NO. | DATE | BY | APP. |
|-----|------|----|------|
| | | | |
| | | | |
| | | | |

**INTERSTATE AVENUE
PAVING PROJECT**

F.A. PROJECT: STPUS-HIPUS-5686(001)
COUNTY ROAD PROJECT NO: 2187D
PLAN
STATION 30+50.00 TO STATION 51+90.00

SHEET
6
OF
15



Donald J Carney, P.E.
Senior Engineer Design
Date: 6/27/19



5/23/21

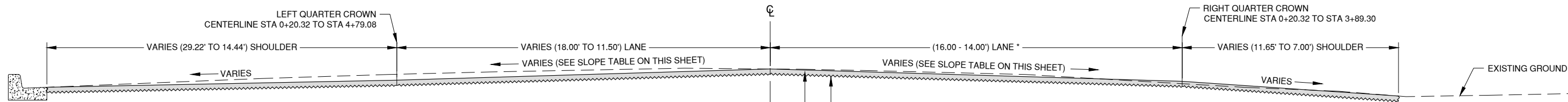

ALL PAVEMENT SHALL BE FOG SEALED WITH CSS1
ONE PASS IN EACH DIRECTION (NEW AND EXISTING ASPHALT)

- ① HMA CLASS 3/8 IN. PG 58H-22 FIBER-REINFORCED WEARING COURSE, 0.20' COMPACTED DEPTH
- ② PLANING BITUMINOUS PAVEMENT, 0.20' DEPTH

* STATION 0+20.32 TO STATION 3+89.30 RIGHT LANE = 16.00'
STATION 3+89.30 TO STATION 4+39.82 RIGHT LANE = 14.00'

ROADWAY TYPICAL SECTION A

STATION 0+20.32 TO STATION 4+39.82
NOT TO SCALE

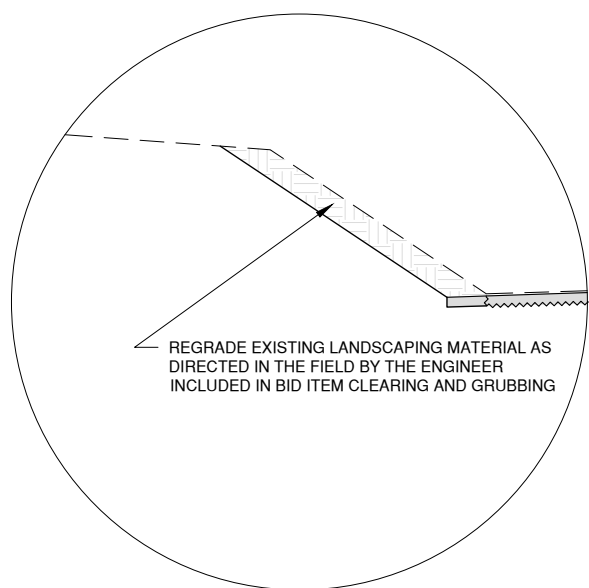

| SLOPE TABLE | | |
|--------------------------|-------------------------------------|-------------------------------------|
| STATION | TRANSVERSE SLOPE LEFT | TRANSVERSE SLOPE RIGHT |
| 0+20.32 (BOP) TO 0+45.00 | MATCH EXISTING | MATCH EXISTING |
| 0+45.00 TO 1+75.00 | TRANSITION EXISTING TO -3.00% | TRANSITION EXISTING TO -3.00% |
| 1+75.00 TO 4+00.00 | -3.00% | -3.00% |
| 4+00.00 TO 4+79.08 | TRANSITION -3.00% TO MATCH EXISTING | TRANSITION -3.00% TO MATCH EXISTING |
| 4+79.08 TO 51+90.00 | MATCH EXISTING | MATCH EXISTING |

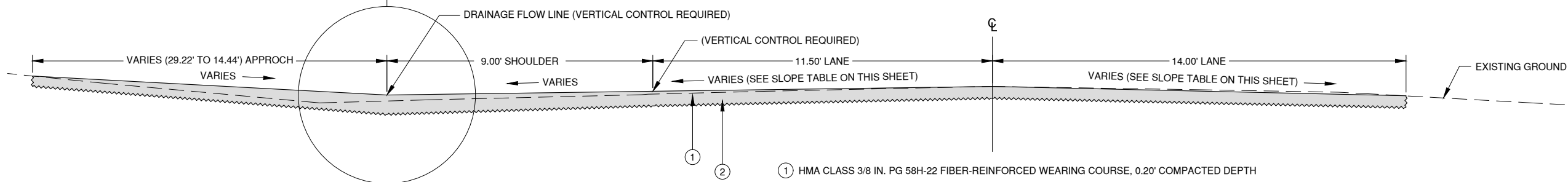

ALL PAVEMENT SHALL BE FOG SEALED WITH CSS1
ONE PASS IN EACH DIRECTION (NEW AND EXISTING ASPHALT)

- ① HMA CLASS 3/8 IN. PG 58H-22 FIBER-REINFORCED WEARING COURSE, 0.20' COMPACTED DEPTH
- ② PLANING BITUMINOUS PAVEMENT, 0.20' DEPTH

ROADWAY TYPICAL SECTION B

STATION 4+39.82 TO STATION 10+10.00
NOT TO SCALE

Lewis County
Department of Public Works
2025 N. E. KRESKY AVE.
CHEHALIS WA 98532
PHONE # (360) 740-1123
FAX # (360) 740-2719

DESIGNED BY : DJC
DRAWN BY : J. PIPER
CHECKED BY :
DATE :

| NO. | DATE | REVISION | BY | APP. |
|-----|------|----------|----|------|
| | | | | |
| | | | | |
| | | | | |

**INTERSTATE AVENUE
PAVING PROJECT**

F.A. PROJECT: STPUS-HIPUS-5686(001)
COUNTY ROAD PROJECT NO: 2187D

ROADWAY TYPICAL SECTION A
ROADWAY TYPICAL SECTION B

SHEET
7
OF
15



Donald J. Carney, P.E.
Senior Engineer Design
Date: 6/27/19



5/23/21

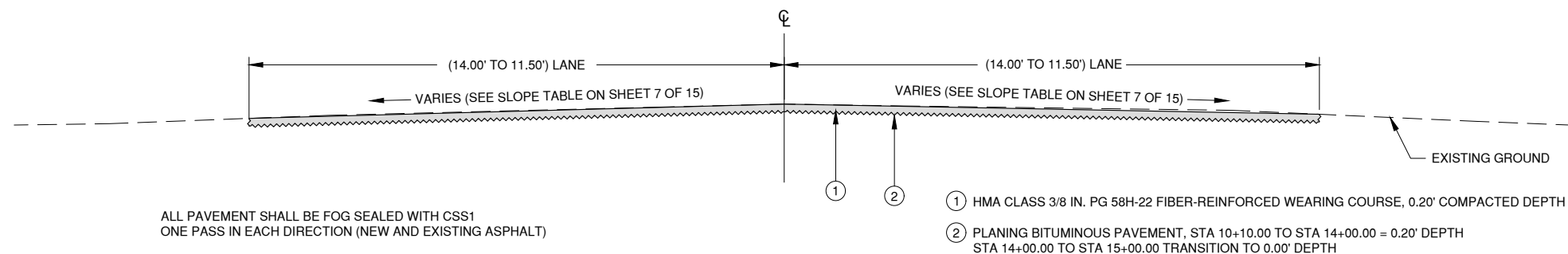

ROADWAY TYPICAL SECTION C
STATION 10+10.00 TO STATION 15+00.00
NOT TO SCALE

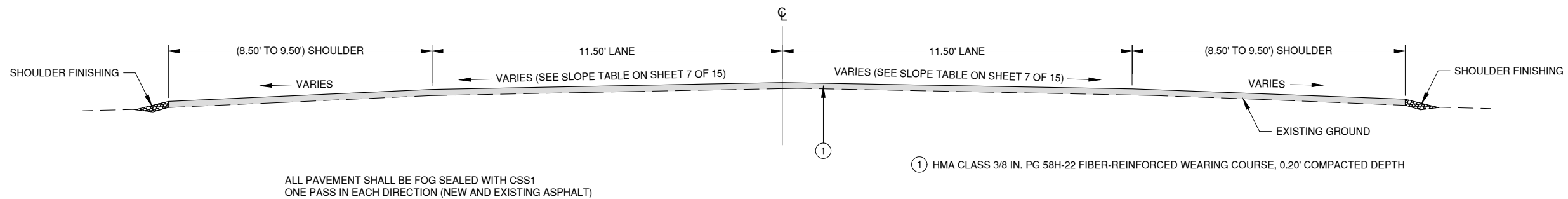

ROADWAY TYPICAL SECTION D
STATION 15+00.00 TO STATION 51+90.00
NOT TO SCALE

Lewis County
Department of Public Works
2025 N. E. KRESKY AVE.
CHEHALIS WA 98532
PHONE # (360) 740-1123
FAX # (360) 740-2719

DESIGNED BY : DJC
DRAWN BY : J. PIPER
CHECKED BY :
DATE :

| NO. | DATE | REVISION | BY | APP. |
|-----|------|----------|----|------|
| | | | | |
| | | | | |
| | | | | |
| | | | | |

**INTERSTATE AVENUE
PAVING PROJECT**

F.A. PROJECT: STPUS-HIPUS-5686(001)
COUNTY ROAD PROJECT NO: 2187D

ROADWAY TYPICAL SECTION C
ROADWAY TYPICAL SECTION D

SHEET
8
OF
15



Donald J Carney, P.E.
Senior Engineer Design
Donald J. Carney
Date: 6/27/19



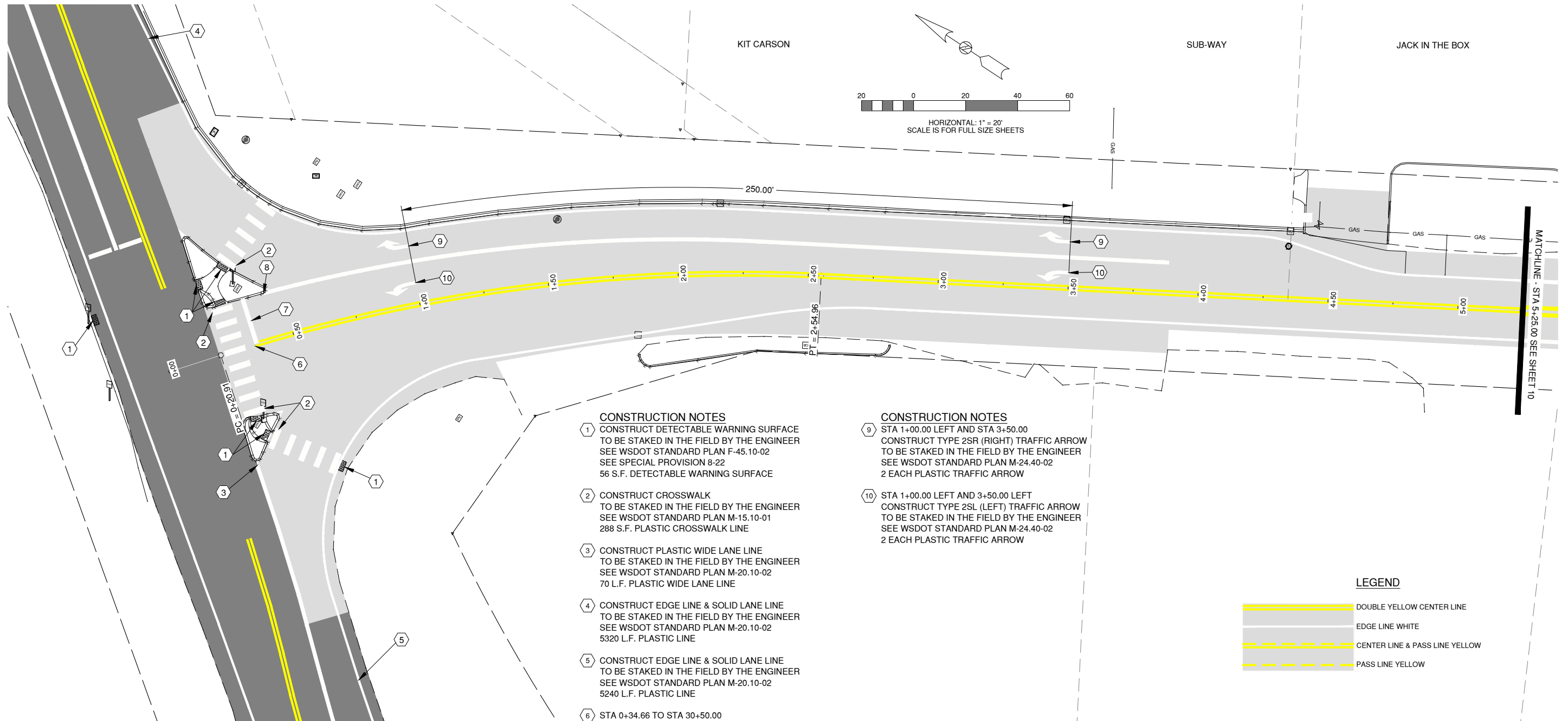

- CONSTRUCTION NOTES**
- 1 CONSTRUCT DETECTABLE WARNING SURFACE TO BE STAKED IN THE FIELD BY THE ENGINEER SEE WSDOT STANDARD PLAN F-45.10-02 SEE SPECIAL PROVISION 8-22 56 S.F. DETECTABLE WARNING SURFACE
 - 2 CONSTRUCT CROSSWALK TO BE STAKED IN THE FIELD BY THE ENGINEER SEE WSDOT STANDARD PLAN M-15.10-01 288 S.F. PLASTIC CROSSWALK LINE
 - 3 CONSTRUCT PLASTIC WIDE LANE LINE TO BE STAKED IN THE FIELD BY THE ENGINEER SEE WSDOT STANDARD PLAN M-20.10-02 70 L.F. PLASTIC WIDE LANE LINE
 - 4 CONSTRUCT EDGE LINE & SOLID LANE LINE TO BE STAKED IN THE FIELD BY THE ENGINEER SEE WSDOT STANDARD PLAN M-20.10-02 5320 L.F. PLASTIC LINE
 - 5 CONSTRUCT EDGE LINE & SOLID LANE LINE TO BE STAKED IN THE FIELD BY THE ENGINEER SEE WSDOT STANDARD PLAN M-20.10-02 5240 L.F. PLASTIC LINE
 - 6 STA 0+34.66 TO STA 30+50.00 CONSTRUCT DOUBLE CENTERLINE TO BE STAKED IN THE FIELD BY THE ENGINEER SEE WSDOT STANDARD PLAN M-20.10-02 6031 L.F. PLASTIC LINE
 - 7 CONSTRUCT STOP LINE TO BE STAKED IN THE FIELD BY THE ENGINEER SEE WSDOT STANDARD PLAN M-24.60-04 18 L.F. PLASTIC STOP LINE
 - 8 STA 0+43.26 LEFT TO STA 3+88.19 LEFT CONSTRUCT PLASTIC WIDE LANE LINE TO BE STAKED IN THE FIELD BY THE ENGINEER SEE WSDOT STANDARD PLAN M-20.10-02 350 L.F. PLASTIC WIDE LANE LINE

- CONSTRUCTION NOTES**
- 9 STA 1+00.00 LEFT AND STA 3+50.00 CONSTRUCT TYPE 2SR (RIGHT) TRAFFIC ARROW TO BE STAKED IN THE FIELD BY THE ENGINEER SEE WSDOT STANDARD PLAN M-24.40-02 2 EACH PLASTIC TRAFFIC ARROW
 - 10 STA 1+00.00 LEFT AND 3+50.00 LEFT CONSTRUCT TYPE 2SL (LEFT) TRAFFIC ARROW TO BE STAKED IN THE FIELD BY THE ENGINEER SEE WSDOT STANDARD PLAN M-24.40-02 2 EACH PLASTIC TRAFFIC ARROW

LEGEND

- DOUBLE YELLOW CENTER LINE
- EDGE LINE WHITE
- CENTER LINE & PASS LINE YELLOW
- PASS LINE YELLOW

MATCHLINE - STA 5+25.00 SEE SHEET 10

2025 NE KRESKY AVE.
CHEHALIS WA 98532
PHONE # (360) 740-1123
FAX # (360) 740-1479

DESIGNED BY :DJC
DRAWN BY : CGA
CHECKED BY :
DATE :

| NO. | DATE | BY | APP. |
|-----|------|----|------|
| | | | |
| | | | |
| | | | |

**INTERSTATE AVENUE
PAVING PROJECT**

F.A. PROJECT: STPUS-HIPUS-5686(001)
COUNTY ROAD PROJECT NO: 2187D
STRIPING
STATION 0+00.00 TO STATION 5+25.00

SHEET
9
OF
15





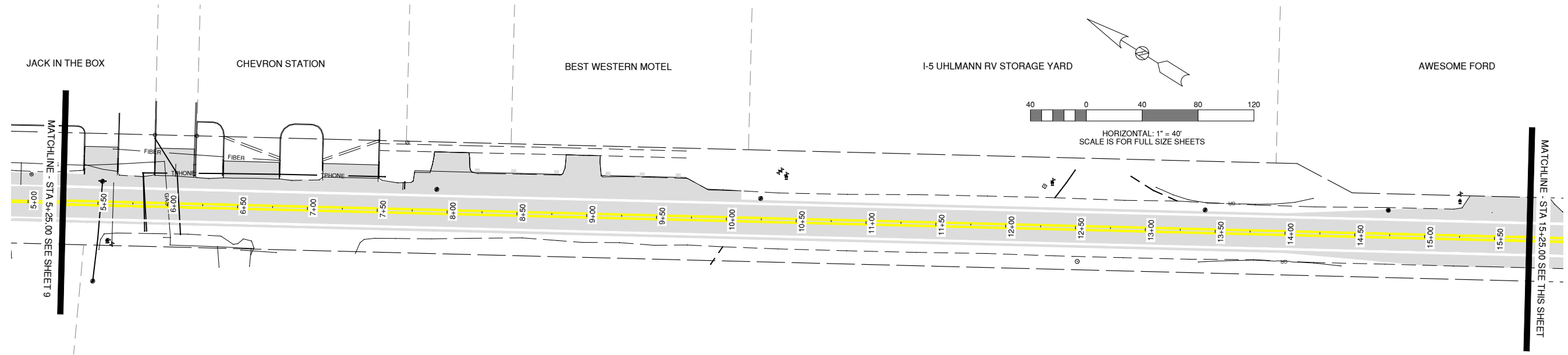

Donald J Carney, P.E.
Senior Engineer Design
Donald J. Carney
Date: 6/27/19



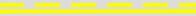

LEGEND

-  DOUBLE YELLOW CENTER LINE
-  EDGE LINE WHITE
-  CENTER LINE & PASS LINE YELLOW
-  PASS LINE YELLOW

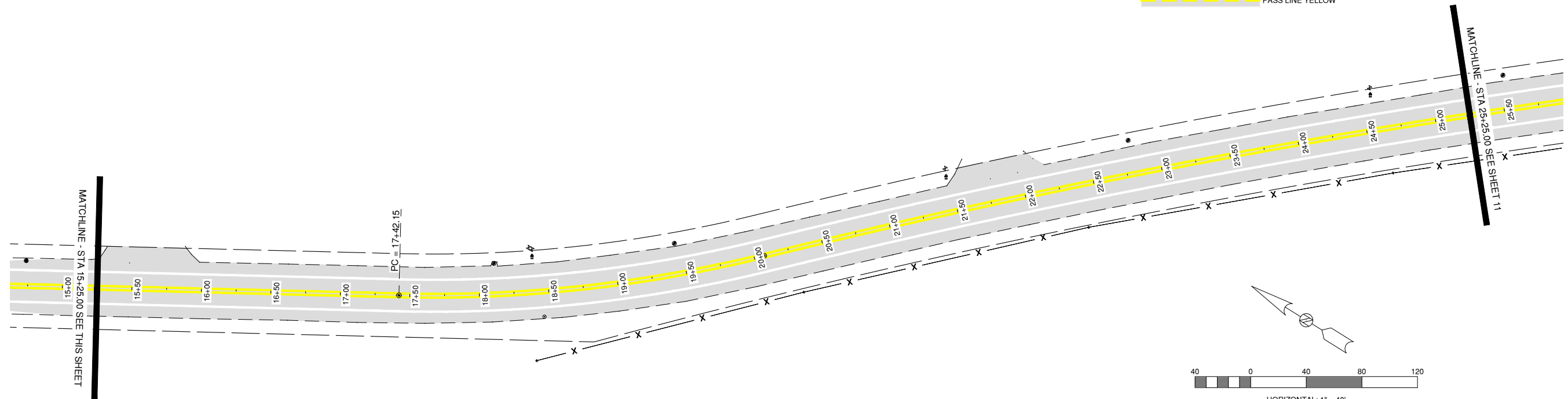

Lewis County
 Department of Public Works
 2025 NE KRESKY AVE.
 CHEHALIS WA 98532
 PHONE # (360) 740-1123
 FAX # (360) 740-1479

DESIGNED BY :DJC
 DRAWN BY : CGA
 CHECKED BY :
 DATE :

| NO. | DATE | BY | APP. |
|-----|------|----|------|
| | | | |
| | | | |
| | | | |

**INTERSTATE AVENUE
 PAVING PROJECT**

F.A. PROJECT: STPUS-HIPUS-5686(001)
 COUNTY ROAD PROJECT NO: 2187D

STRIPING
 STATION 5+25.00 TO STATION 25+25.00

SHEET
10
 OF
15



Donald J Carney, P.E.
 Senior Engineer Design
 Date: 6/27/19



5/23/21

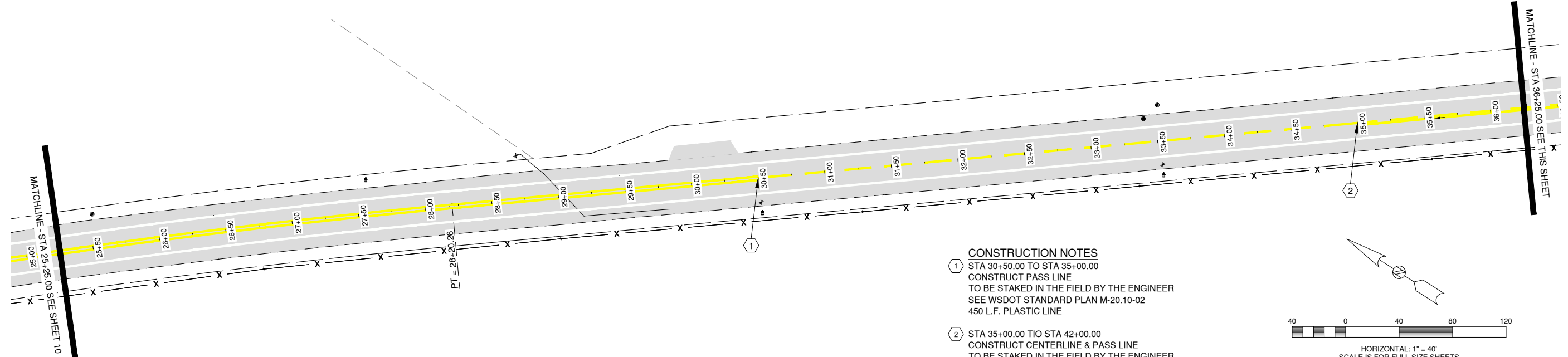

- CONSTRUCTION NOTES**
- ① STA 30+50.00 TO STA 35+00.00
CONSTRUCT PASS LINE
TO BE STAKED IN THE FIELD BY THE ENGINEER
SEE WSDOT STANDARD PLAN M-20.10-02
450 L.F. PLASTIC LINE
 - ② STA 35+00.00 TO STA 42+00.00
CONSTRUCT CENTERLINE & PASS LINE
TO BE STAKED IN THE FIELD BY THE ENGINEER
SEE WSDOT STANDARD PLAN M-20.10-02
1400 L.F. PLASTIC LINE

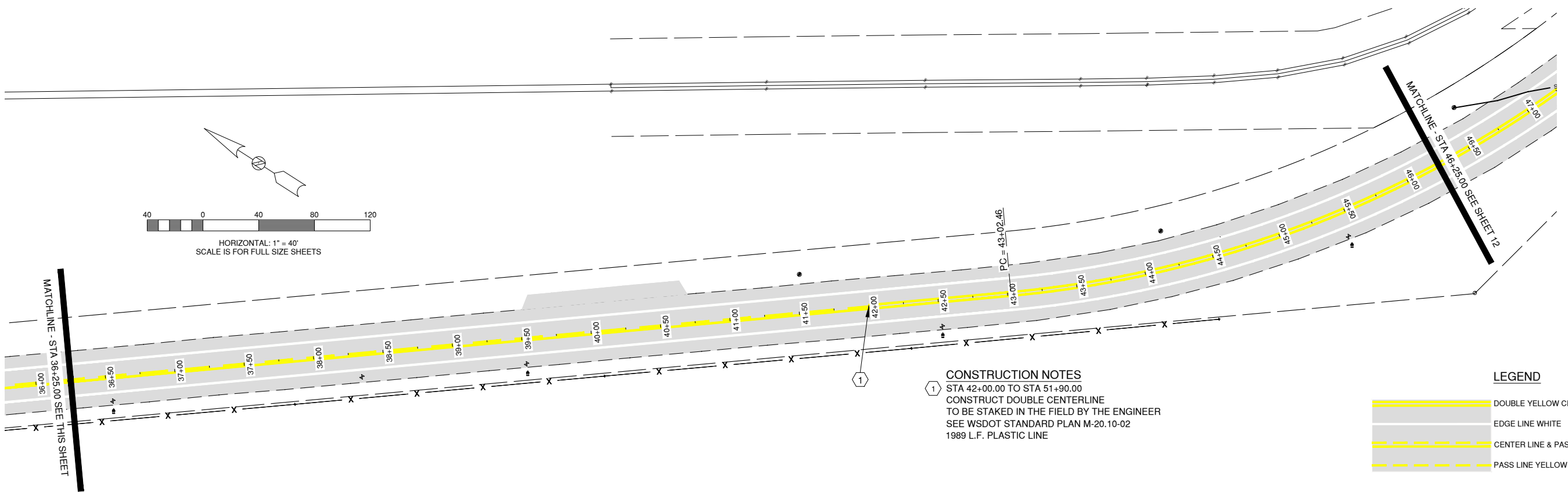
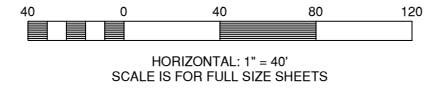

- CONSTRUCTION NOTES**
- ① STA 42+00.00 TO STA 51+90.00
CONSTRUCT DOUBLE CENTERLINE
TO BE STAKED IN THE FIELD BY THE ENGINEER
SEE WSDOT STANDARD PLAN M-20.10-02
1989 L.F. PLASTIC LINE

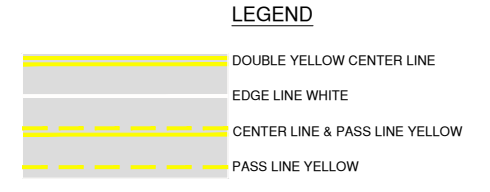

2025 NE KRESKY AVE.
CHEHALIS WA 98532
PHONE # (360) 740-1123
FAX # (360) 740-1479

DESIGNED BY :DJC
DRAWN BY : CGA
CHECKED BY :
DATE :

| NO. | DATE | BY | APP. |
|-----|------|----|------|
| | | | |
| | | | |
| | | | |

INTERSTATE AVENUE PAVING PROJECT

F.A. PROJECT: STPUS-HIPUS-5686(001)
COUNTY ROAD PROJECT NO: 2187D

STRIPING
STATION 25+25.00 TO STATION 46+25.00

SHEET
11
OF
15

CALL 48 HOURS
BEFORE YOU DIG

1-800-
424-5555
"It's the Law"
Utilities
Underground
Location Center

Donald J Carney, P.E.
Senior Engineer Design

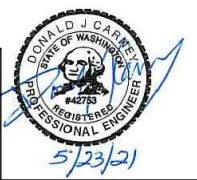

Donald J Carney
Date: 6/27/19

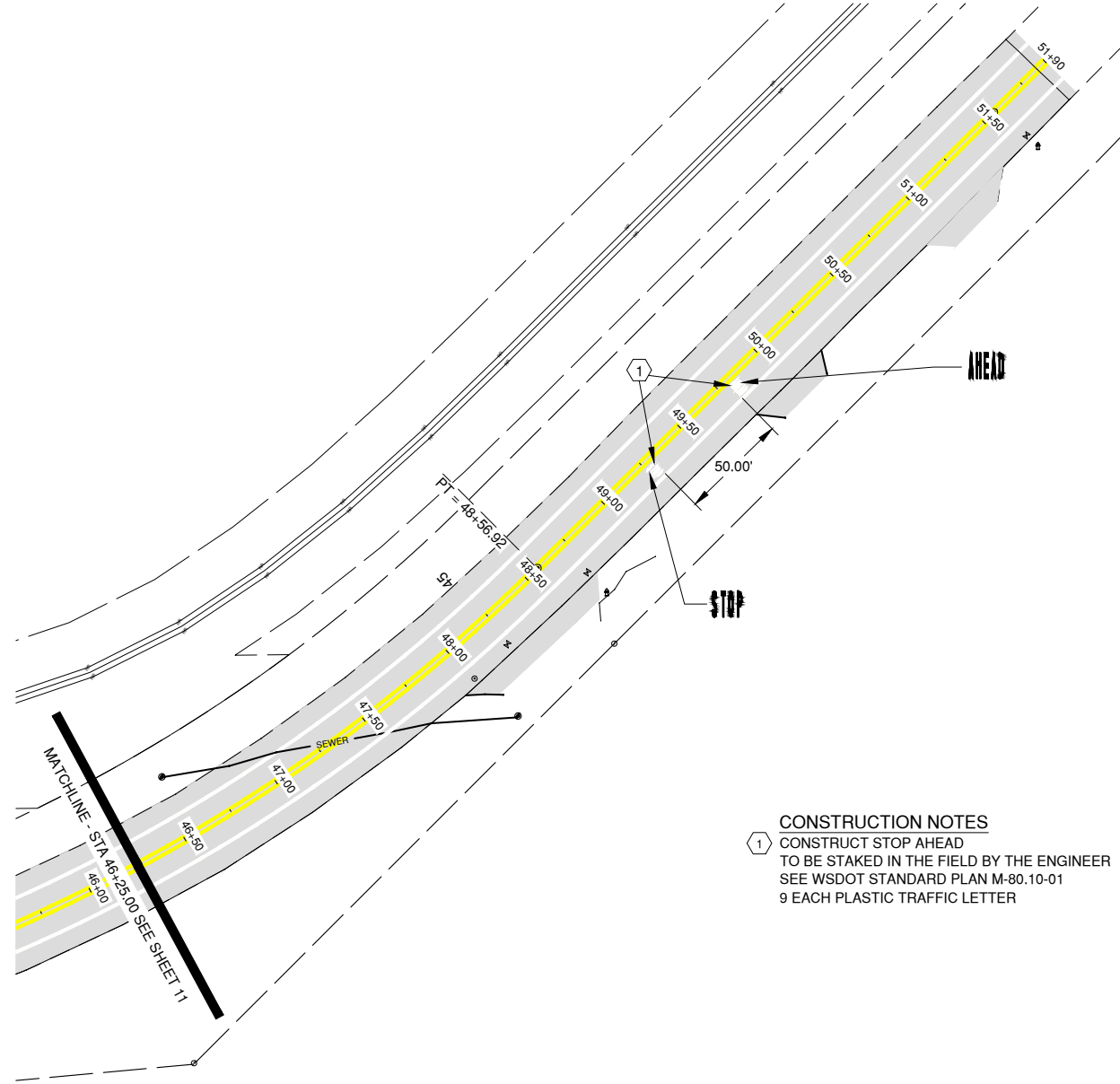
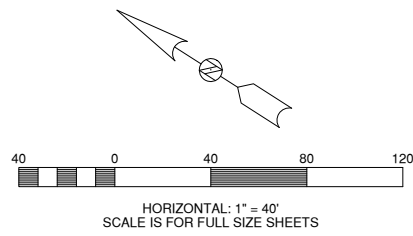

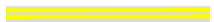
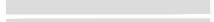

CONSTRUCTION NOTES
 1 CONSTRUCT STOP AHEAD
 TO BE STAKED IN THE FIELD BY THE ENGINEER
 SEE WSDOT STANDARD PLAN M-80.10-01
 9 EACH PLASTIC TRAFFIC LETTER

LEGEND

-  DOUBLE YELLOW CENTER LINE
-  EDGE LINE WHITE
-  CENTER LINE & PASS LINE YELLOW
-  PASS LINE YELLOW



2025 NE KRESKY AVE.
 CHEHALIS WA 98532
 PHONE # (360) 740-1123
 FAX # (360) 740-1479

DESIGNED BY :DJC
 DRAWN BY : CGA
 CHECKED BY :
 DATE :

| NO. | DATE | BY | APP. |
|-----|------|----|------|
| | | | |
| | | | |
| | | | |
| | | | |

**INTERSTATE AVENUE
 PAVING PROJECT**

F.A. PROJECT: STPUS-HIPUS-5686(001)
 COUNTY ROAD PROJECT NO: 2187D
 STRIPING
 STATION 46+25.00 TO STATION 51+90.00

SHEET
12
 OF
15



Donald J Carney, P.E.
 Senior Engineer Design
 Date: 6/27/19



5/23/21

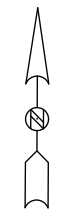
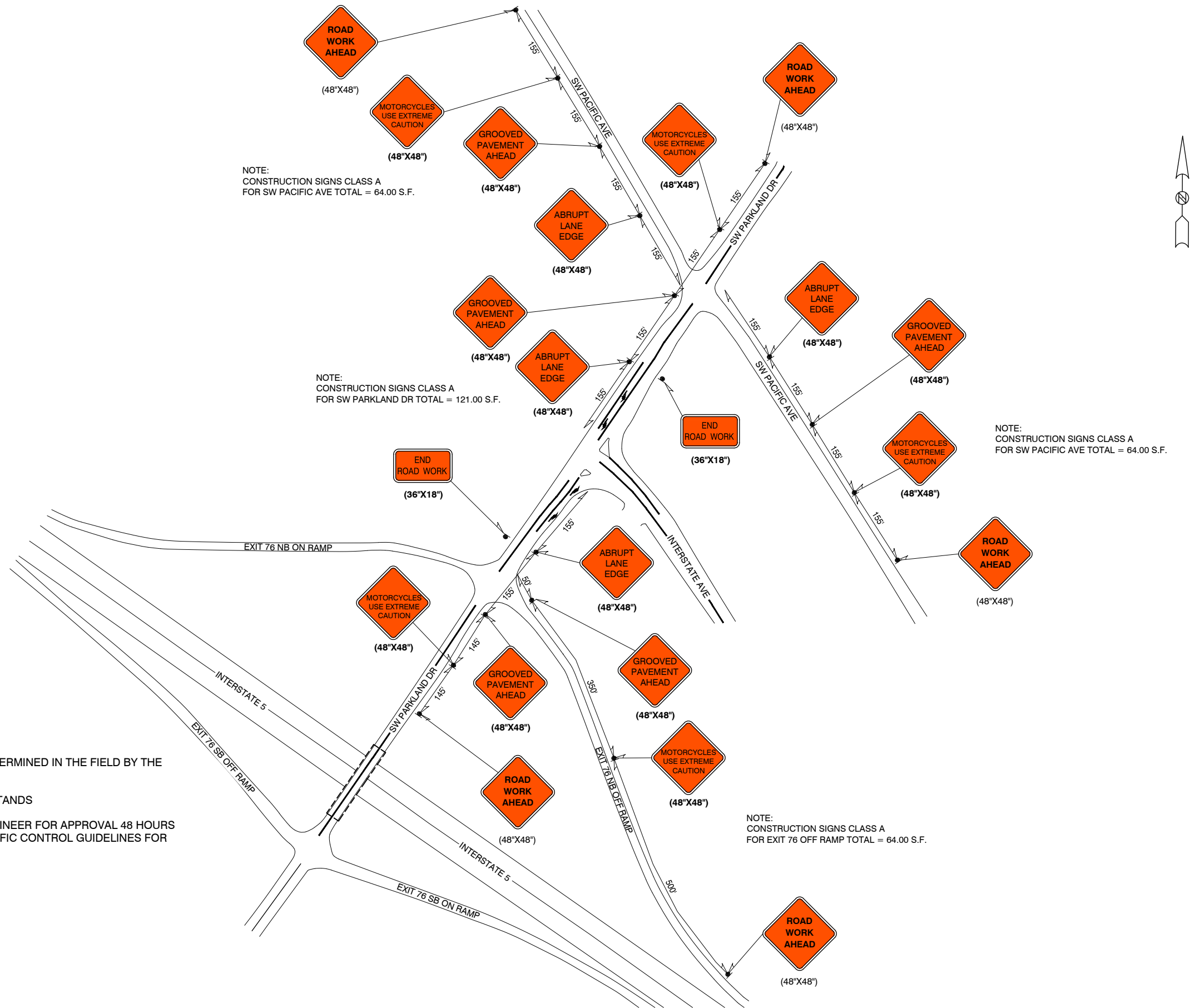

NOTES

- ALL SIGNS ARE TO BE BLACK ON ORANGE UNLESS OTHERWISE NOTED.
- SIGN LOCATIONS ARE APPROXIMATE. ACTUAL LOCATIONS ARE TO BE DETERMINED IN THE FIELD BY THE ENGINEER.
- ALL CONSTRUCTION SIGNS CLASS A, ARE TO BE PLACED ON WEIGHTED STANDS
- TEMPORARY TRAFFIC CONTROL PLANS SHALL BE SUBMITTED TO THE ENGINEER FOR APPROVAL 48 HOURS BEFORE IMPLEMENTATION AND SHALL USE THE WSDOT WORK ZONE TRAFFIC CONTROL GUIDELINES FOR MAINTENANCE OPERATIONS FOR GUIDANCE.

LEGEND

● CONSTRUCTION SIGN CLASS A (SEE SPECIAL PROVISION)

Lewis County
 Department of Public Works
 2025 N. E. KRESKY AVE.
 CHEHALIS WA 98532
 PHONE # (360) 740-1123
 FAX # (360) 740-2719

DESIGNED BY : DJC
 DRAWN BY : KLC
 CHECKED BY :
 DATE :

| NO. | DATE | REVISION | BY | APP. |
|-----|------|----------|----|------|
| | | | | |
| | | | | |
| | | | | |

**INTERSTATE AVENUE
PAVING PROJECT**

F.A. PROJECT: STPUS-HIPUS-5686(001)
 COUNTY ROAD PROJECT NO: 2187D

CONSTRUCTION SIGNS CLASS A

SHEET
13
 OF
15



Donald J Carney, P.E.
 Senior Engineer Design
Donald J Carney
 Date: 6/27/19



5/23/21

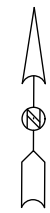
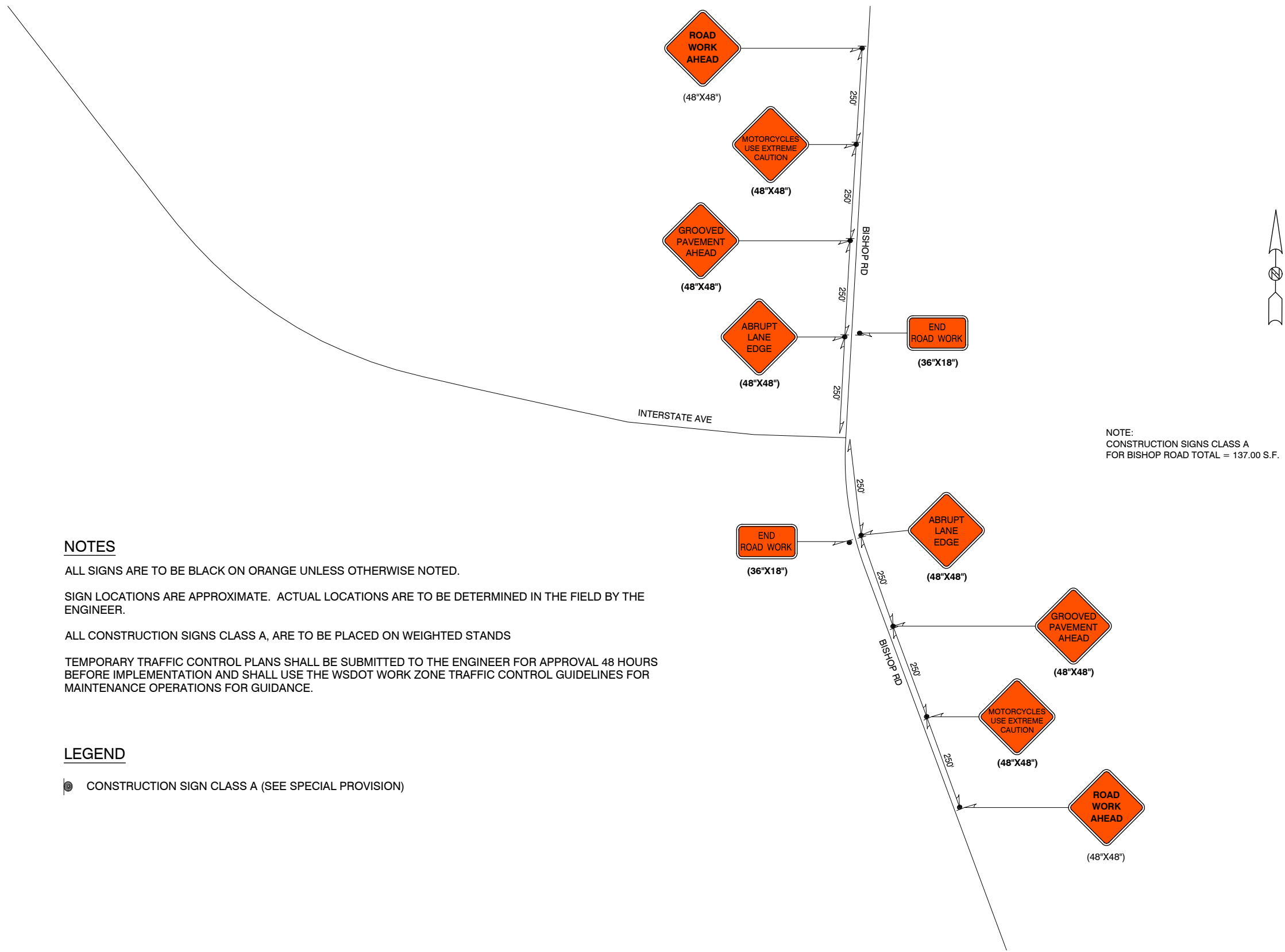

NOTE:
CONSTRUCTION SIGNS CLASS A
FOR BISHOP ROAD TOTAL = 137.00 S.F.

NOTES

- ALL SIGNS ARE TO BE BLACK ON ORANGE UNLESS OTHERWISE NOTED.
- SIGN LOCATIONS ARE APPROXIMATE. ACTUAL LOCATIONS ARE TO BE DETERMINED IN THE FIELD BY THE ENGINEER.
- ALL CONSTRUCTION SIGNS CLASS A, ARE TO BE PLACED ON WEIGHTED STANDS
- TEMPORARY TRAFFIC CONTROL PLANS SHALL BE SUBMITTED TO THE ENGINEER FOR APPROVAL 48 HOURS BEFORE IMPLEMENTATION AND SHALL USE THE WSDOT WORK ZONE TRAFFIC CONTROL GUIDELINES FOR MAINTENANCE OPERATIONS FOR GUIDANCE.

LEGEND

- CONSTRUCTION SIGN CLASS A (SEE SPECIAL PROVISION)

Lewis County
Department of Public Works
2025 N. E. KRESKY AVE.
CHEHALIS WA 98532
PHONE # (360) 740-1123
FAX # (360) 740-2719

DESIGNED BY : DJC
DRAWN BY : KLC
CHECKED BY :
DATE :

| NO. | DATE | REVISION | BY | APP. |
|-----|------|----------|----|------|
| | | | | |
| | | | | |
| | | | | |

**INTERSTATE AVENUE
PAVING PROJECT**

F.A. PROJECT: STPUS-HIPUS-5686(001)
COUNTY ROAD PROJECT NO: 2187D
CONSTRUCTION SIGNS CLASS A

SHEET
14
OF
15



Donald J Carney, P.E.
Senior Engineer Design
Donald J Carney
Date: 6/27/19



NOTES

ALL SIGNS ARE TO BE BLACK ON ORANGE UNLESS OTHERWISE NOTED.

THIS SHEET IS TO SUPPLEMENT WORK ZONE TRAFFIC CONTROL PLAN TC-1

TEMPORARY TRAFFIC CONTROL PLANS SHALL BE SUBMITTED TO THE ENGINEER FOR APPROVAL 48 HOURS BEFORE IMPLEMENTATION AND SHALL USE THE WSDOT WORK ZONE TRAFFIC CONTROL GUIDELINES FOR MAINTENANCE OPERATIONS FOR GUIDANCE.

TYPE 2 BARRICADES SHALL HAVE A 48" IN X 30" ROAD CLOSED SIGN ATTACHED TO BARRICADE IN TRAVELED LANE



3 FLAGGERS AND 1 SPOTTER WILL BE UTILIZED FOR ALL WORKING OPERATIONS ON THIS SITE
 * FLAGGER NEEDED DURING ROAD CLOSURE ONLY

| CHANNELIZATION DEVICE SPACING (FEET) | | |
|--------------------------------------|----------|---------|
| MPH | TAPER | TANGENT |
| 50/60 | 10 TO 20 | 80 |
| 35/45 | 10 TO 20 | 60 |
| 25/30 | 10 TO 20 | 40 |

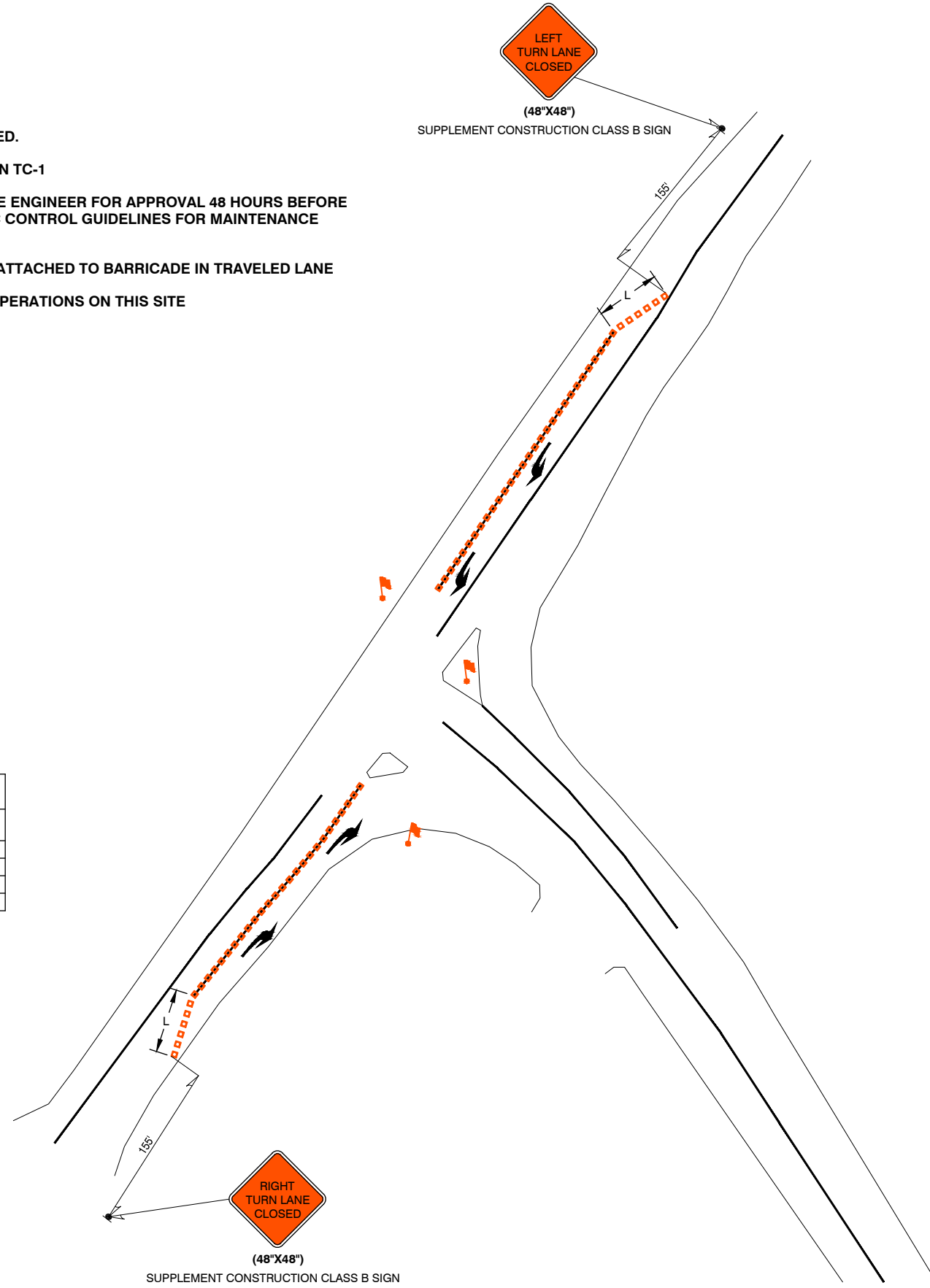
| LANE WIDTH (FEET) | MINIMUM TAPER LENGTH = L (FEET) | | | | | | | | | |
|-------------------|---------------------------------|-----|-----|-----|-----|-----|-----|-----|----|----|
| | POSTED SPEED (MPH) | | | | | | | | | |
| | 25 | 30 | 35 | 40 | 45 | 50 | 55 | 60 | 65 | 70 |
| 10 | 105 | 150 | 205 | 270 | 450 | 500 | 550 | - | - | - |
| 11 | 115 | 165 | 225 | 295 | 495 | 550 | 605 | 660 | - | - |
| 12 | 125 | 180 | 245 | 320 | 540 | 600 | 660 | 720 | - | - |



LEGEND

-  SUPPLEMENT CONSTRUCTION SIGN CLASS B
-  FLAGGING STATION
-  CHANNELIZING DEVICES



Lewis County
 Department of Public Works
 2025 N. E. KRESKY AVE.
 CHEHALIS WA 98532
 PHONE # (360) 740-1123
 FAX # (360) 740-2719

DESIGNED BY : DJC
 DRAWN BY : KLC
 CHECKED BY :
 DATE :

| NO. | DATE | REVISION | BY | APP. |
|-----|------|----------|----|------|
| | | | | |
| | | | | |
| | | | | |

**INTERSTATE AVENUE
 PAVING PROJECT**

F.A. PROJECT: STPUS-HIPUS-5686(001)
 COUNTY ROAD PROJECT NO: 2187D
 SUPPLEMENT TRAFFIC CONTROL PLAN

SHEET
15
 OF
15



Donald J Carney, P.E.
 Senior Engineer Design
 Date: 6/27/19

