



U.S. Department  
of Transportation  
**Federal Highway  
Administration**

1200 New Jersey Ave., SE  
Washington, D.C. 20590

September 29, 2016

In Reply Refer To:  
HSST-1/B-264

Ms. Karla Lechtenberg  
Midwest Roadside Safety Facility  
130 Whitter Research Center  
2200 Vine Street  
Lincoln, NE 68583-0853

Dear Ms. Lechtenberg,

This letter is in response to your October 15, 2015, request for the Federal Highway Administration (FHWA) to review a roadside safety device, hardware, or system for eligibility for reimbursement under the Federal-aid highway program. This FHWA letter of eligibility is assigned FHWA control number B-264 and is valid until a subsequent letter is issued by FHWA that expressly references this device.

**Decision**

The following devices are eligible, with details provided in the form which is attached as an integral part of this letter:

- Side-Mounted Weak-Post Guardrail Attached to Culvert

**Scope of this Letter**

To be found eligible for Federal-aid funding, new roadside safety devices should meet the crash test and evaluation criteria contained in the American Association of State Highway and Transportation Officials (AASHTO) Manual for Assessing Safety Hardware (MASH). However, FHWA, the U.S. Department of Transportation (DOT), and the U.S. Government do not regulate the manufacture of roadside safety devices. Eligibility for reimbursement under the Federal-aid highway program does not establish approval, certification or endorsement of the device for any particular purpose or use.

This letter is not a determination by FHWA, DOT, or the U.S. Government that a vehicle crash involving the device will result in any particular outcome, nor is it a guarantee of the in-service performance of this device. Proper manufacturing, installation, and maintenance are required in order for this device to function as tested.

This finding of eligibility is limited to the crashworthiness of the system and does not cover other structural features, nor conformity with the Manual on Uniform Traffic Control Devices.

**Eligibility for Reimbursement**

Based solely on a review of crash test results and certifications submitted by the manufacturer, and the crash test laboratory, FHWA agrees that the device described herein meets the crash test

and evaluation criteria of AASHTO MASH. Therefore, the device is eligible for reimbursement under the Federal-aid highway program if installed under the range of tested conditions.

Name of system: Side-Mounted Weak-Post Guardrail Attached to Culvert

Type of system: Longitudinal Barrier

Test Level: MASH Test Level 3 (TL3)

Testing conducted by: Midwest Roadside Safety Facility

Date of request: October 15, 2015

Date initially acknowledged: October 20, 2015

Date of completed package: August 12, 2016

The FHWA concurs with the recommendation of the accredited crash testing laboratory as stated within the attached form.

#### **Full Description of the Eligible Device**

The device and supporting documentation, including reports of the crash tests or other testing done, videos of any crash testing, and/or drawings of the device, are described in the attached form.

#### **Notice**

If a manufacturer makes any modification to any of their roadside safety hardware that has an existing eligibility letter from FHWA, the manufacturer must notify FHWA of such modification with a request for continued eligibility for reimbursement. The notice of all modifications to a device must be accompanied by:

- o Significant modifications – For these modifications, crash test results must be submitted with accompanying documentation and videos.
- o Non-signification modifications – For these modifications, a statement from the crash test laboratory on the potential effect of the modification on the ability of the device to meet the relevant crash test criteria.

The FHWA determination of continued eligibility for the modified hardware will be based on whether the modified hardware will continue to meet the relevant crash test criteria.

You are expected to supply potential users with sufficient information on design, installation and maintenance requirements to ensure proper performance.

You are expected to certify to potential users that the hardware furnished has the same chemistry, mechanical properties, and geometry as that submitted for review, and that it will meet MASH test and evaluation criteria.

Issuance of this letter does not convey property rights of any sort or any exclusive privilege. This letter is based on the premise that information and reports submitted by you are accurate and correct. We reserve the right to modify or revoke this letter if: (1) there are any inaccuracies in the information submitted in support of your request for this letter; (2) the qualification testing was flawed; (3) in-service performance or other information reveals safety problems; (4) the system is significantly different from the version that was crash tested; or (5) any other

information indicates that the letter was issued in error or otherwise does not reflect full and complete information about the crashworthiness of the system.

### Standard Provisions

- To prevent misunderstanding by others, this letter of eligibility designated as FHWA control number B-264 shall not be reproduced except in full. This letter and the test documentation upon which it is based are public information. All such letters and documentation may be reviewed upon request.
- This letter shall not be construed as authorization or consent by FHWA to use, manufacture, or sell any patented system for which the applicant is not the patent holder.
- If the subject device is a patented product it may be considered to be proprietary. If proprietary systems are specified by a highway agency for use on Federal-aid projects: (a) they must be supplied through competitive bidding with equally suitable unpatented items; (b) the highway agency must certify that they are essential for synchronization with the existing highway facilities or that no equally suitable alternative exists; or (c) they must be used for research or for a distinctive type of construction on relatively short sections of road for experimental purposes. Our regulations concerning proprietary products are contained in Title 23, Code of Federal Regulations, Section 635.411.

Sincerely yours,



(For) Michael S. Griffith  
Director, Office of Safety Technologies

Enclosures

## Request for Federal Aid Reimbursement Eligibility of Highway Safety Hardware

<b>Submitter</b>	Date of Request:	August 11, 2016	<input type="radio"/> New <input checked="" type="radio"/> Resubmission
	Name:	Karla Lechtenberg	
	Company:	Midwest Roadside Safety Facility	
	Address:	130 Whittier Research Center, 2200 Vine Street, Lincoln, NE 68583-0853	
	Country:	USA	
	To:	Michael S. Griffith, Director FHWA, Office of Safety Technologies	

I request the following devices be considered eligible for reimbursement under the Federal-aid highway program.

**Device & Testing Criterion** - Enter from right to left starting with Test Level

|-|-|

System Type	Submission Type	Device Name / Variant	Testing Criterion	Test Level
'B': Rigid/Semi-Rigid Barriers (Roadside, Median, Bridge Railings)	<input type="radio"/> Physical Crash Testing <input checked="" type="radio"/> Engineering Analysis	Side-Mounted Weak-Post Guardrail Attached to Culvert	AASHTO MASH	TL3

By submitting this request for review and evaluation by the Federal Highway Administration, I certify that the product(s) was (were) tested in conformity with the AASHTO Manual for Assessing Safety Hardware and that the evaluation results meet the appropriate evaluation criteria in the MASH.

**Individual or Organization responsible for the product:**

Contact Name:	Karla Lechtenberg	Same as Submitter <input checked="" type="checkbox"/>
Company Name:	Midwest Roadside Safety Facility	Same as Submitter <input checked="" type="checkbox"/>
Address:	130 Whittier Research Center, 2200 Vine Street, Lincoln, NE 68583-0853	Same as Submitter <input checked="" type="checkbox"/>
Country:	USA	Same as Submitter <input checked="" type="checkbox"/>

Enter below all disclosures of financial interests as required by the FHWA 'Federal-Aid Reimbursement Eligibility Process for Safety Hardware Devices' document.

The Midwest Roadside Safety Facility (MwRSF) and its employees are requesting a letter of eligibility on behalf of the state departments of transportation participating in the Midwest States Regional Pooled Fund Program.

MwRSF's financial interests are as follows:

- (i) No compensation, including wages, salaries, commissions, professional fees, or fees for business referrals;
- (ii) Consulting relationships consist of answering design and implementation questions;
- (iii) Research funding or other forms of research support include continuing to fund research projects with MwRSF;
- (iv) No patents, copyrights, or other intellectual property interests for this system;
- (v) No licenses or contractual relationships for this system; and
- (vi) No business ownership and investment interests for this system.



## PRODUCT DESCRIPTION

<input type="radio"/> New Hardware or Significant Modification	<input checked="" type="radio"/> Modification to Existing Hardware	Non-Significant
<p>The Slide-Mounted Weak-Post Guardrail Attached to Culvert (SGR53) is an adaptation of the weak-post MGS bridge rail that allows for attachment to the outside face of culvert headwalls. It utilizes 44-in. long S3x5.7 steel posts with standoffs (PSF01) spaced at half-post spacing, or 37½ in. on center, and mounted in steel side-mounted bracket assemblies. The slide-mounted bracket assemblies consists of a top mounting plate, two gussets, a tube socket, and a bottom mounting plate welded together. The top mounting plate is a 1/2 in. thick, 3 in. wide, and 10 in. long ASTM A572 Grade 50 steel plate. The gussets are a 1/2 in. thick, 2 5/8 in. wide, and 2 5/8 in. long ASTM A572 Grade 50 steel plate. The tube socket is a 16 1/2-in. long, 4-in. x 4-in. x 3/8-in. square ASTM A500 steel tube. The bottom mounting plate is a 1/2 in. thick, 3 in wide, and 8 in. long ASTM A572 Grade 50 steel plate. The side-mounted bracket assemblies are anchored to the culvert with a 13-in. long, 1 1/8-in. diameter ASTM A307 Grade C threaded rod (FRR28a) that passes through the upper strap of the socket and is embedded 10 inches into the top of the culvert headwall using an epoxy with a minimum bond strength of 1,300 psi and secured with a washer (FWC30a) and nut (FNX28a). Two 7-in. long, 1/2-in. diameter ASTM A307 Grade C threaded rods (FRR14a), one on each side of the socket tube, are used to attach the bottom mounting plate to the outside face of the headwall. The 1/2-in. threaded rods (FRR14a) are embedded 4 1/2 inches into the headwall using an epoxy with a minimum bond strength of 1,300 psi and are secured on the outside by a washer (FWC12a) and a nut (FNX12a). The center of the threaded rods (FRR28a and FRR14a) should be placed a minimum of 4 inches from the free end of a culvert headwall. A 5-in. long, 5/8-in. diameter ASTM A325 Type 1 hex bolt (FBX16a) was passed through the web of the post and both sides of the socket. The rail consists of standard 12-gauge W-beam sections (RWM04a) installed with the top of the rail set at a nominal height of 31 inches. A 12-in. long, 12-gauge backup plate (RWB01a) is used to block the rail away from the front face of the steel post. The rail splices are located at posts. The rail is attached to the posts with 1 1/4-in. long, 5/16-in. diameter ASTM A307 Grade A bolts and nuts (FBX08a) and a 1¾-in. x 1¾-in. x 1/8-in. square washer (FWR01) positioned between the bolt head and the traffic-side face of the rail. The culvert should have a minimum 28-day compressive strength of 4,000 psi.</p> <p>A stiffness transition between the Top-Mounted Weak-Post Guardrail Attached to Culvert and adjacent standard MGS installations is not necessary. A 75-in. spacing is recommended between the last weak-post on the culvert and the first standard guardrail post of the adjacent MGS installation which can be either blocked or non-blocked MGS. The first standard guardrail post adjacent to the culvert should be placed a minimum of 12 inches from the culvert and any wingwalls. Guardrail terminals (or end anchorages) should be located a sufficient distance from the culvert to prevent the two systems from interfering with the proper performance of one another. Therefore, the following implementation guidelines should be considered in addition to guardrail length of need requirements:</p> <p>(1) A minimum length of 12 ft – 6 in. of standard MGS is recommended between the first weak post and the interior end of an acceptable TL-3 guardrail end terminal.</p> <p>(2) A minimum barrier length of 50 ft is recommended before the first weak post, which includes standard MGS and a crashworthy guardrail end terminal. This guidance applies to the downstream end as well.</p> <p>(3) For flared guardrail applications, a minimum length of 25 ft is recommended between the first weak post and the start of the flared section (i.e., bend between flared and tangent sections).</p>		
<h3>CRASH TESTING</h3>		
<p>By signature below, the Engineer affiliated with the testing laboratory, agrees in support of this submission that the Modification to Existing Hardware is deemed Non-significant for the device listed above to meet the MASH criteria.</p>		
Engineer Name:	Scott Rosenbaugh	
Engineer Signature:	<h2 style="margin: 0;">Scott Rosenbaugh</h2> <small>Digitally signed by Scott Rosenbaugh DN: cn=Scott Rosenbaugh, o=MWR5F, ou, email=srosenbaugh2@unl.edu, c=US Date: 2016.08.12 07:50:17 -05'00'</small>	
Address:	130 Whittier Research Center, 2200 Vine Street, Lincoln, NE 68583-0853	Same as Submitter <input checked="" type="checkbox"/>
Country:	USA	Same as Submitter <input checked="" type="checkbox"/>

## A brief description of each crash test and its result:

Required Test Number	Narrative Description	Evaluation Results
3-10 (1100C)	<p>The Side-Mounted Weak-Post Guardrail Attached to Culvert is an adaptation of the weak-post Midwest Guardrail System (MGS) bridge rail that allows for attachment to the outside face of culvert headwalls. If the new components (which are the attachment and anchorage hardware utilized to mount the socket flush with the outside face of the culvert headwall) are shown to withstand extreme loading conditions without damage to the socket assembly or the culvert headwall, the Side-Mounted Weak-Post Guardrail attached to Culvert would perform similarly to the original weak-post MGS bridge rail. The original weak-post MGS bridge rail has been tested, satisfies the MASH TL-3 testing criteria, and has an FHWA Eligibility Letter (B-228). The results of full-scale crash testing conducted on the original weak-post MGS bridge rail can be found in MwRSF report no. TRP-03-226-10.</p> <p>Dynamic component testing consisted of a longitudinal impact (0-degree impact angle) on the post at a height of 12 in., resulting in weak-axis bending. This is believed to be a critical loading condition that represents a small car bumper impacting posts during a redirection and induces high shear loads into the socket and may cause the socket to rotate.</p> <p>The results of test no. CP-6D2 (longitudinal impact) conducted on August 1, 2012 are found in MwRSF report no. TRP-03-277-14. A 1,816-lb rigid-frame bogie vehicle impacted the post at a speed of 21.0 mph and at an angle of 0 degrees. Immediately upon impact, the top of the socket shifted downward 1/8 in. due to construction tolerances and the distance between the socket and the top anchor. A plastic hinge formed in the post adjacent to the top-downstream edge of the socket as the post bent over. The bogie overrode the post at 0.086 seconds after impact. The socket and attachment hardware were intact and encountered minimal plastic deformations at the top of the socket. The epoxied anchors showed no signs of slippage or pullout. The culvert headwall was free of concrete cracking and spalling.</p>	Modification has no effect on crashworthiness

Required Test Number	Narrative Description	Evaluation Results
3-11 (2270P)	<p>The Side-Mounted Weak-Post Guardrail Attached to Culvert is an adaptation of the weak-post Midwest Guardrail System (MGS) bridge rail that allows for attachment to the outside face of culvert headwalls. If the new components (which are the attachment and anchorage hardware utilized to mount the socket flush with the outside face of the culvert headwall) are shown to withstand extreme loading conditions without damage to the socket assembly or the culvert headwall, the Side-Mounted Weak-Post Guardrail attached to Culvert would perform similarly to the original weak-post MGS bridge rail. The original weak-post MGS bridge rail has been tested, satisfies the MASH TL-3 testing criteria, and has an FHWA Eligibility Letter (B-228). The results of full-scale crash testing conducted on the original weak-post MGS bridge rail can be found in MwRSF report no. TRP-03-226-10.</p> <p>Dynamic component testing consisted of a lateral impact (90-degree impact angle) on the post at a height of 24 7/8 in., resulting in strong-axis bending. This is believed to be a critical loading condition which matches the height to the center of the W-beam rail and represents maximum lateral loading into the guardrail system.</p> <p>The results of test no. CP-5D2 (lateral impact) conducted on July 31, 2012 are found in MwRSF report no. TRP-03-277-14. A 1,875-lb rigid-frame bogie vehicle impacted the post at a speed of 20.5 mph and at an angle of 90 degrees. A plastic hinge formed in the post adjacent to the top-back edge of the socket as the post bent over. The bogie overrode the post at 0.092 seconds after impact. The socket and attachment hardware were intact and did not encounter plastic deformations. The epoxied anchors showed no signs of slippage or pullout. The culvert headwall was free of concrete cracking and spalling.</p>	Modification has no effect on crashworthiness
3-20 (1100C)	Test no. 3-20 is not applicable for this type of system.	Non-Relevant Test, not conducted
3-21 (2270P)	Test no. 3-31 is not applicable for this type of system.	Non-Relevant Test, not conducted



Testing Laboratory's signature concurs that these modifications are considered Non-Significant.		
Laboratory Name:	Midwest Roadside Safety Facility	
Laboratory Signature:	<b>Karla Lechtenberg</b>	<small>Digitally signed by Karla Lechtenberg DN: cn=Karla Lechtenberg, o=Midwest Roadside Safety Facility (MWRSF), ou, email=lpolivka2@unl.edu, c=US Date: 2016.08.12 10:11:25 -0500</small>
Address:	130 Whittier Research Center, 2200 Vine Street, Lincoln, NE 68583-0853	Same as Submitter <input checked="" type="checkbox"/>
Country:	USA	Same as Submitter <input checked="" type="checkbox"/>
Accreditation Certificate Number and Dates of current Accreditation period :	A2LA Certificate Number: 2937.01, Valid to November 30, 2017	

Submitter Signature\*: **Karla Lechtenberg**

Digitally signed by Karla Lechtenberg  
DN: cn=Karla Lechtenberg, o=Midwest  
Roadside Safety Facility (MWRSF), ou  
email=lpolivka2@unl.edu, c=US  
Date: 2016.08.12 10:11:41 -0500

Submit Form

## ATTACHMENTS

Attach to this form:

- 1) Additional disclosures of related financial interest as indicated above.
- 2) A copy of the full test report, video, and a Test Data Summary Sheet for each test conducted in support of this request.
- 3) A drawing or drawings of the device(s) that conform to the Task Force-13 Drawing Specifications [Hardware Guide Drawing Standards]. For proprietary products, a single isometric line drawing is usually acceptable to illustrate the product, with detailed specifications, intended use, and contact information provided on the reverse. Additional drawings (not in TF-13 format) showing details that are relevant to understanding the dimensions and performance of the device should also be submitted to facilitate our review.

**FHWA Official Business Only:**

Eligibility Letter		Key Words
Number	Date	

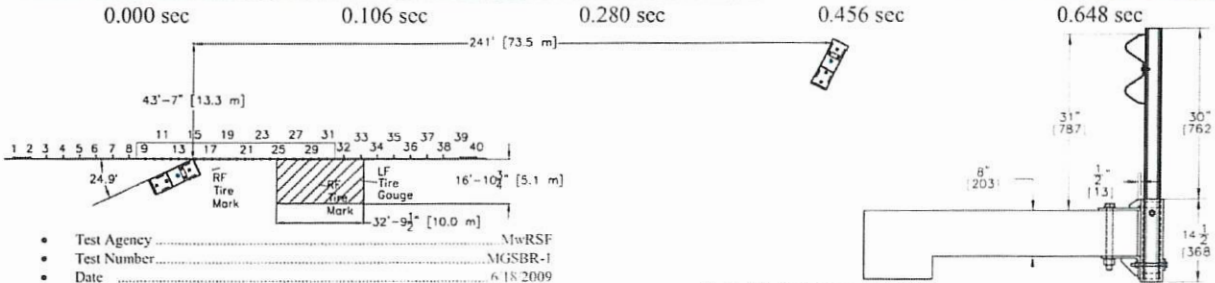
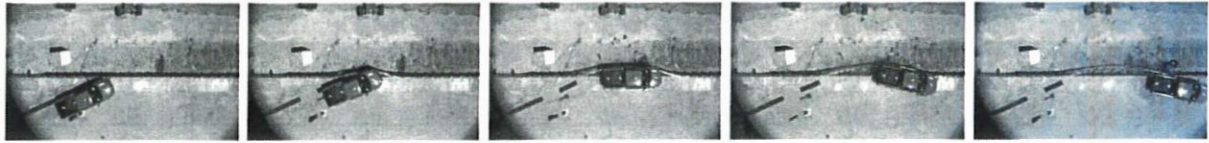

- Test Agency ..... MnRSF
- Test Number ..... MGSBR-1
- Date ..... 6/18/2009
- MASH Test Designation ..... 3-11
- Test Article ..... MGS Bridge Rail with approach MGS Guardrails
- Total Length ..... 175 ft (53.3 m)
- Key Component - MGS Bridge Rail
  - Post Type ..... S3x5.7 (S76x8.5)
  - Post Spacing ..... 3 ft - 1 1/2 in. (953 mm)
  - Post-to-Rail Connection ..... 5/16-in. (7.9-mm) dia. ASTM A307A Bolt
- Key Component - Simulated Bridge Deck
  - Thickness (outer edge) ..... 8 in. (203 mm)
  - Concrete Strength (minimum) ..... 4,000 psi (27.6 MPa)
- Vehicle Model ..... 2004 Dodge Ram 1500 Quad Cab Pickup Truck
- Curb ..... 5,134 lb (2,329 kg)
- Test Inertial ..... 5,005 lb (2,270 kg)
- Gross Static ..... 5,174 lb (2,347 kg)
- Impact Conditions
  - Speed ..... 61.9 mph (99.6 km/h)
  - Angle ..... 24.9 degrees
  - Impact Location ..... 15 ft - 9 1/2 in. (4.81 m) US of post no. 20 splice
- Exit Conditions
  - Speed ..... 34.5 mph (55.5 km/h)
  - Angle ..... 20.4 degrees
  - Exit Box ..... Pass
- Vehicle Stability ..... Satisfactory
- Vehicle Stopping Distance ..... 241 ft (73.5 m) downstream  
43 ft - 7 in. (13.3 m) behind edge of bridge deck
- Vehicle Damage ..... Moderate
  - VDS<sup>1</sup> ..... 11-LFQ-3
  - CDC<sup>1</sup> ..... 11-L-YEW-4
  - Maximum Interior Deformation ..... 1 1/2 in. (44 mm), left side panel
- Test Article Damage ..... Moderate

- Test Article Deflections
  - Permanent Set ..... 31 1/2 in. (810 mm)
  - Dynamic ..... 48.9 in. (1,242 mm)
  - Working Width ..... 53.2 in. (1,351 mm)
- Angular Displacements (EDR-4)
  - Roll ..... -15.3 degrees
  - Pitch ..... -5.6 degrees
  - Yaw ..... 37.8 degrees
- Angular Displacements (DTS)
  - Roll ..... -14.0 degrees
  - Pitch ..... -5.4 degrees
  - Yaw ..... 39.8 degrees

Evaluation Criteria	Transducer			MASH Limit
	EDR-4	DTS	EDR-3	
OIV ft/s (m/s)	Longitudinal	-16.94 ft/s (-5.16 m/s)	-16.86 ft/s (-5.14 m/s)	≤ 40 (12.2)
	Lateral	13.27 ft/s (4.04 m/s)	14.23 ft/s (4.34 m/s)	≤ 40 (12.2)
ORA g's	Longitudinal	-10.61	-10.44	≤ 20.49
	Lateral	5.42	6.33	≤ 20.49
THIV - ft/s (m/s)	20.66 ft/s (6.30 m/s)	21.03 ft/s (6.41 m/s)		not required
PHD - g's	10.64	10.50		not required
ASI	0.53	0.57	0.64	not required

Figure 127. Summary of Test Results and Photographs. Test No. MGSBR-1

214

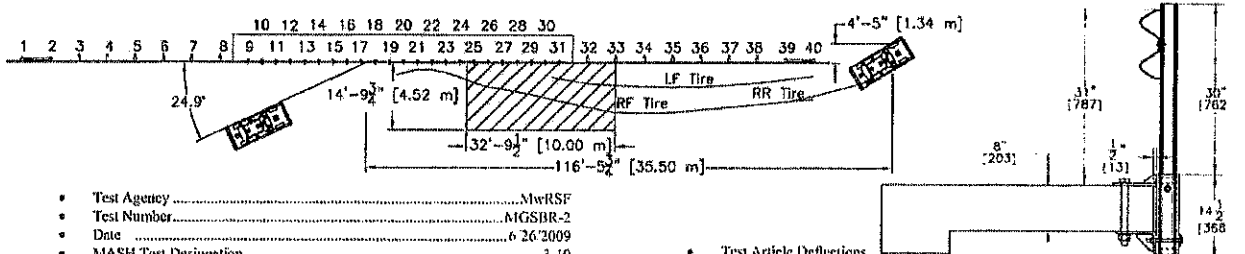
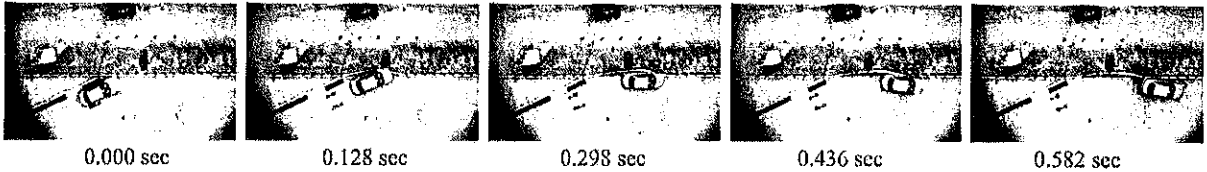

- Test Agency ..... MWRSF
- Test Number ..... MGSBR-2
- Date ..... 6/26/2009
- MASH Test Designation ..... 3-10
- Test Article ..... MGS Bridge Rail with approach MGS Guardrails
- Total Length ..... 175 ft (53.3 m)
- Key Component - MGS Bridge Rail
  - Post Type ..... S3x5.7 (S76x8.5)
  - Post Spacing ..... 3 ft - 1 1/2 in. (953 mm)
  - Post-to-rail Connection ..... 3/8 in. (7.9-mm) dia. ASTM A307A Bolt
- Key Component - Simulated Bridge Deck
  - Thickness (outer edge) ..... 8 in. (203 mm)
  - Concrete Strength (minimum) ..... 4,000 psi (27.6 MPa)
- Vehicle Model ..... 2003 Kia Rio Passenger Car
- Curb ..... 2,468 lb (1,092 kg)
- Test Inertial ..... 2,416 lb (1,096 kg)
- Gross Static ..... 2,585 lb (1,173 kg)
- Impact Conditions
  - Speed ..... 62.3 mph (100.2 km/h)
  - Angle ..... 24.9 degrees
  - Impact Location ..... 7 ft - 9 in. (2.36 m) US of the splice at post no. 20
- Exit Conditions
  - Speed ..... 27.7 mph (44.6 km/h)
  - Angle ..... 10.9 degrees
  - Exit Box ..... Pass
- Vehicle Stability ..... Satisfactory
- Vehicle Stopping Distance ..... 116 ft - 5 1/2 in. (35.5 m) downstream
- Vehicle Damage ..... Moderate
- VDS<sup>(1)</sup> ..... 11-L,FQ-4
- CDC<sup>(1)</sup> ..... 11-LY,BW-5
- Maximum Interior Deformation ..... 1/2 in. (32 mm), front of floor pan
- Test Article Damage ..... Moderate

- Test Article Deflections
  - Permanent Set ..... 20 in. (508 mm)
  - Dynamic ..... 28.0 in. (712 mm)
  - Working Width ..... 33.8 in. (859 mm)
- Angular Displacements (EDR-4)
  - Roll ..... -8.7 degrees
  - Pitch ..... -8.2 degrees
  - Yaw ..... 34.7 degrees
- Angular Displacements (DTS)
  - Roll ..... -12.7 degrees
  - Pitch ..... -5.0 degrees
  - Yaw ..... 35.1 degrees
- Transducer Data

Evaluation Criteria		Transducer			MASH Limit
		EDR-4	DTS	EDR-3	
OIV ft/s (m/s)	Longitudinal	-24.40 ft/s (-7.44 m/s)	-22.90 ft/s (-6.98 m/s)	-23.29 ft/s (-7.17 m/s)	≤ 40 (12.2)
	Lateral	16.54 ft/s (5.04 m/s)	16.38 ft/s (4.99 m/s)	17.94 ft/s (5.17 m/s)	≤ 40 (12.2)
ORA g's	Longitudinal	-7.69	-7.41	-8.65	≤ 20.49
	Lateral	6.58	7.34	7.39	≤ 20.49
THIV - ft/s (m/s)		28.50 ft/s (8.69 m/s)	28.04 ft/s (8.55 m/s)		not required
PHD - g's		9.93	9.90		not required
ASI		0.79	0.78	0.88	not required

Figure 152. Summary of Test Results and Photographs. Test No. MGSBR-2



PLAN VIEW

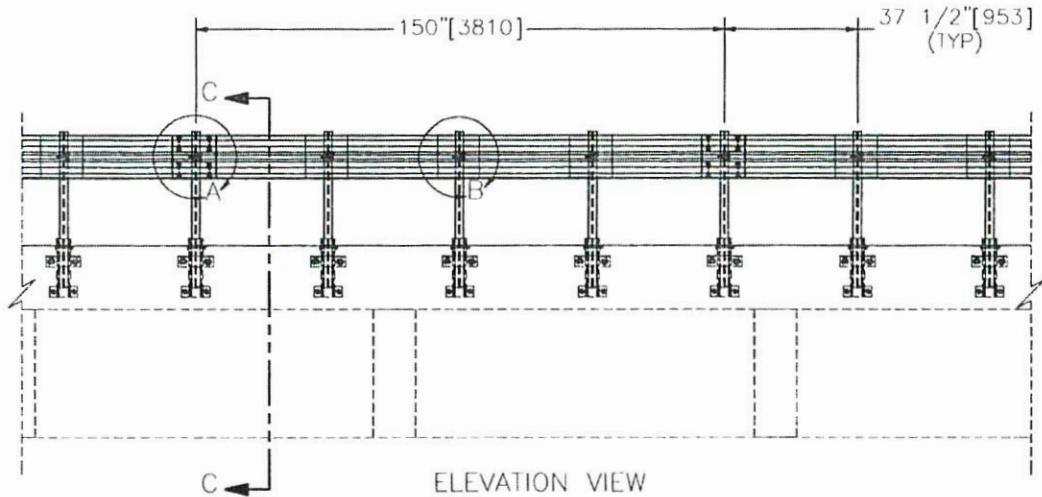

ELEVATION VIEW

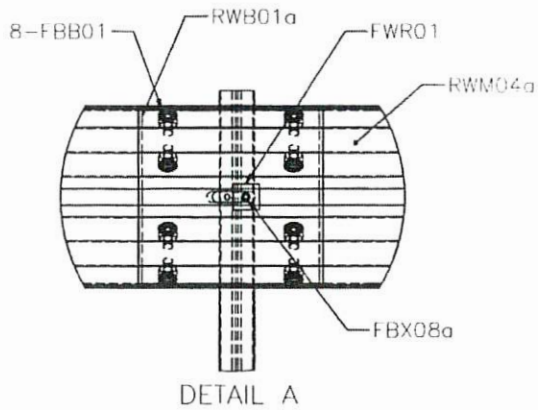

DETAIL A

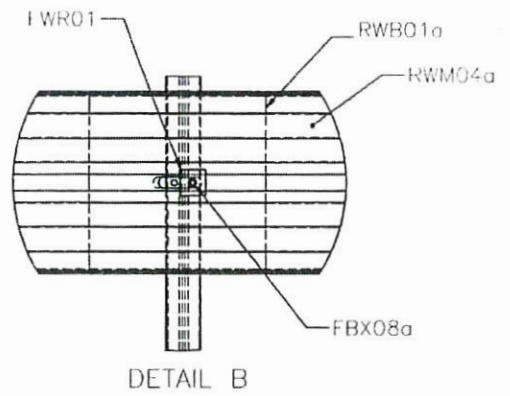

DETAIL B

SIDE-MOUNTED WEAK-POST GUARDRAIL ATTACHED TO CULVERT



SGR53

SHEET NO.

DATE:

1 of 7

5/28/2015

### INTENDED USE

The Side-Mounted Weak-Post Guardrail Attached to Culvert is designed as a treatment to continue W-beam guardrail systems across large box culverts. It is compatible with the Midwest Guardrail System (MGS) with or without blockouts (SGR20a-c or SGR41) such that an approach transition would not be required between the two barriers. The Side-Mounted Weak-Post Guardrail Attached to Culvert is an adaptation of the MGS Bridge Rail (SBO02c) with only the socket length and attachment hardware changing. All post and rail components are identical to the original MGS Bridge Rail (SBO02c). The Top-Mounted Weak-Post Guardrail Attached to Culvert is TL-3 accepted, and is accepted according to the Manual for Assessing Safety Hardware (MASH) safety performance criteria.

The Side-Mounted Weak-Post Guardrail Attached to Culvert is one of two configurations for the Weak-Post Guardrail Attached to Culvert. The other configuration is a Top-Mounted Weak-Post Guardrail Attached to Culvert (SGR52).

A stiffness transition between the new guardrail attached to culvert system and adjacent MGS installation (SGR20a-c or SGR41) is unnecessary. A 75-in. [1905] spacing is recommended between the last S3x5.7 (S76x8.5) culvert post (PSF01) and the first guardrail post of the adjacent MGS installation. The adjacent MGS may be either blocked or non-blocked (SGR20a-c or SGR41).

### COMPONENTS

Unit Length = 150" [3810]

DESIGNATOR	COMPONENT	NUMBER
PSF01	S3x5.7 by 44" long Post and Standoff	4
RWM04a	12'-6" W-Beam MGS Section 1/2 Post Spacing	1
RWB01a	12" W-Beam Backup Plate	4
FBX08a	Hex Bolt 5/16"-18x1 1/4"x1 1/4" and Nut	4
RWR01	1 3/4"x1 3/4"x1/8" Square Guardrail Washer	4
FBB01	5/8" Dia., 1 1/2" Long Guardrail Bolt and Nut	8
FBX16a	Hex Bolt 5/8"-11x5"x1 1/4" and Nut	4
-----	Side-Mounted Bracket Assembly	4
FWC20a	3/4" Plain Round Washer	8
FWC12a	1/2" Plain Round Washer	8
FRR20b	3/4" Dia., 11" Long Threaded Rod	8
FNX20a	3/4" Dia. Hex Nut	8
FRR12b	1/2" Dia., 7" Long Threaded Rod	8
FNX12a	1/2" Dia. Hex Nut	8

## SIDE-MOUNTED WEAK-POST GUARDRAIL ATTACHED TO CULVERT



# SGR53

SHEET NO.

DATE:

2 of 7

5/28/2015

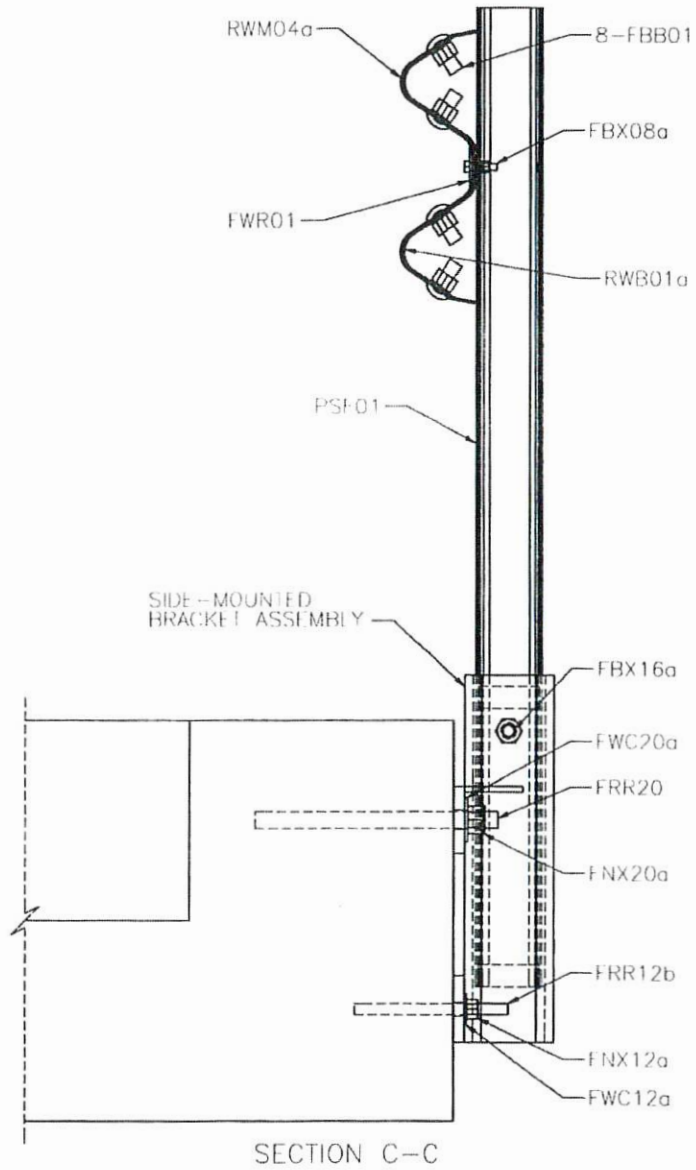

SIDE-MOUNTED WEAK-POST GUARDRAIL ATTACHED TO CULVERT



SGR53

SHEET NO.

DATE:

3 of 7

5/28/2015

### ELIGIBILITY

FHWA Eligibility is being pursued.

### REFERENCES

Schneider, A.J., Rosenbaugh, S.K., Faller, R.K., Sicking, D.L., Lechtenberg, K.A., and Reid, J.D., *Safety Performance Evaluation of Weak-Post, W-Beam Guardrail Attached to Culvert*, Final Report to the Midwest States Pooled Fund Program, MwRSF Research Report No. TRP-03-277-14, Midwest Roadside Safety Facility, University of Nebraska-Lincoln, Lincoln, Nebraska, February 12, 2014.

Rosenbaugh, S.K., Faller, R.K., Lechtenberg, K.A., and Bielenberg, R.W., *Weak-Post, W-Beam Guardrail Attachment to Culvert Headwalls*, Paper No. 14-3930, Transportation Research Record No. 2437, Journal of the Transportation Research Board, TRB AFB20 Committee on Roadside Safety Design, Transportation Research Board, Washington D.C., January 2014, pages 41-51.

### CONTACT INFORMATION

Midwest Roadside Safety Facility  
University of Nebraska-Lincoln  
130 Whittier Research Center  
2200 Vine Street  
Lincoln, NE 68583-0853  
(402) 472-0965  
Email: [mwrsf@unl.edu](mailto:mwrsf@unl.edu)  
Website: <http://mwrsf.unl.edu/>

## SIDE-MOUNTED WEAK-POST GUARDRAIL ATTACHED TO CULVERT



## SGR53

SHEET NO.

DATE:

4 of 7

5/28/2015

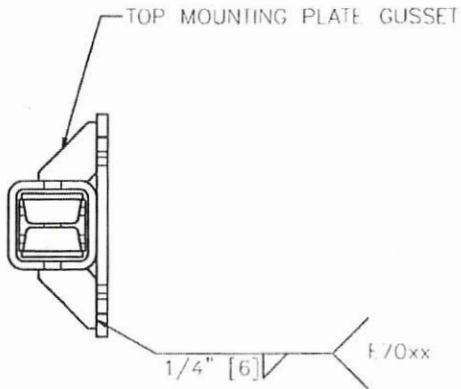

PLAN VIEW

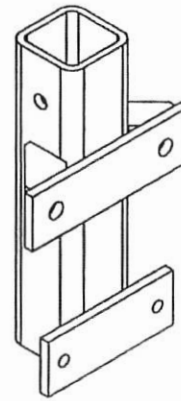

ISOMETRIC VIEW

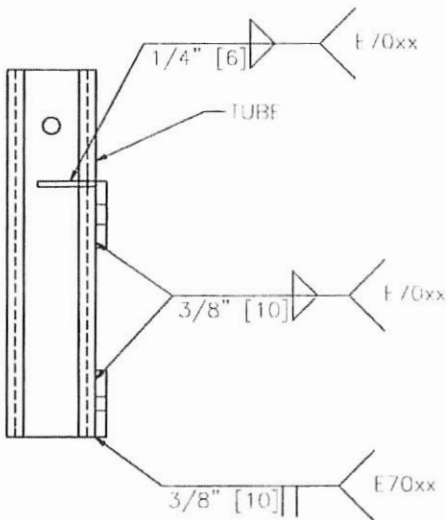

ELEVATION VIEW

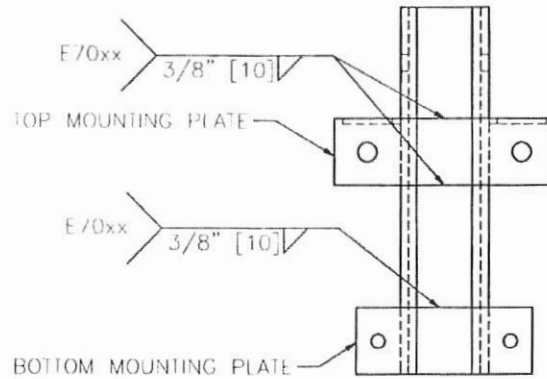

PROFILE VIEW

SIDE-MOUNTED BRACKET ASSEMBLY

SIDE-MOUNTED WEAK-POST GUARDRAIL ATTACHED TO CULVERT



SGR53

SHEET NO.

DATE:

5 of 7

5/28/2015



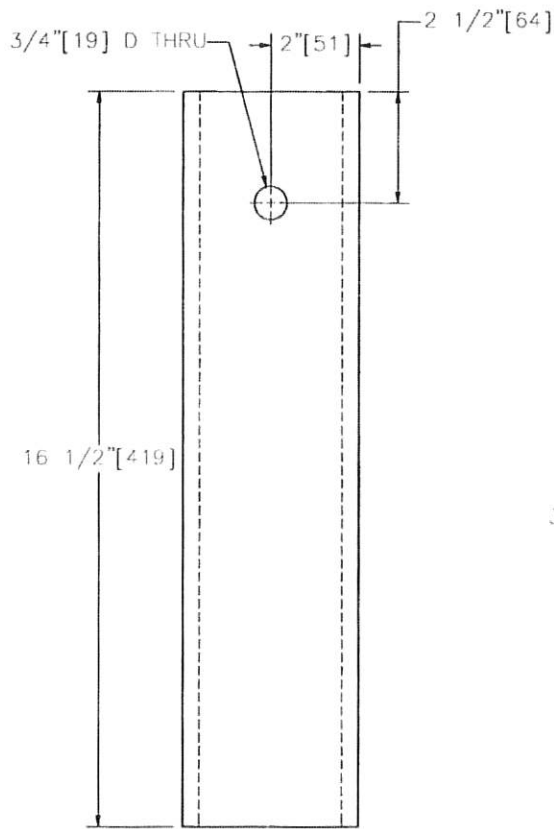

ELEVATION VIEW  
4"x4"x3/8" [102x102x10] TUBE

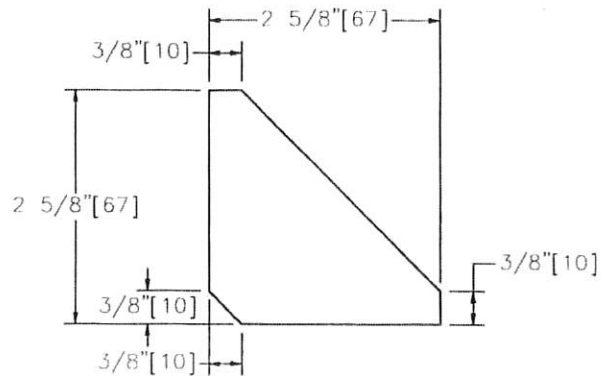

ELEVATION VIEW  
1/2" [13] THICK TOP MOUNTING PLATE GUSSET

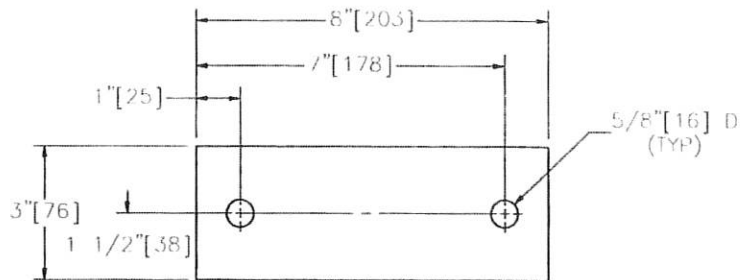

ELEVATION VIEW  
1/2" [13] THICK BOTTOM MOUNTING PLATE

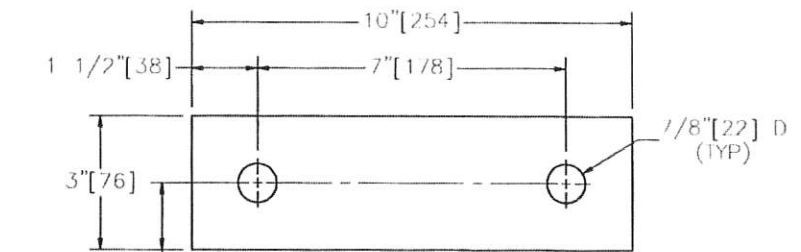

ELEVATION VIEW  
1/2" [13] THICK TOP MOUNTING PLATE

SIDE-MOUNTED WEAK-POST GUARDRAIL ATTACHED TO CULVERT



SGR53

SHEET NO.

DATE:

6 of 7

5/28/2015

## SPECIFICATIONS

### 4"x4" Square Tube

The square tube shall be ASTM A500 grade B galvanized steel.

### Top Mounting Plate

The top mounting plate shall be ASTM A572 grade 50 galvanized steel.

### Top Mounting Plate Gusset

The top mounting plate gusset shall be ASTM A572 grade 50 galvanized steel.

### Bottom Mounting Plate

The bottom mounting plate shall be ASTM A572 grade 50 galvanized steel.

SIDE-MOUNTED WEAK-POST GUARDRAIL ATTACHED TO CULVERT



SGR53

SHEET NO.

DATE:

7 of 7

5/28/2015