

**LEWIS COUNTY FIRE DISTRICT #3
MOSSYROCK FIRE STATION
JOB NO. 17-01**

ADDENDUM NO. 3
October 02, 2020

This Addendum forms a part of the Contract Documents and modifies the original Contract Documents as described. Acknowledge receipt of this Addendum in the space provided on the Form of Proposal. Failure to do so may subject Bidder to disqualification. There are 128 pages to this addendum including all attachments. This Addendum is issued to all known Plan Holders.

MECHANICAL SPECIFICATIONS

1. **ADD** attached Mechanical Specifications Index.
2. **ADD** attached Section 20 02 00 - Operation and Maintenance Manual for Mechanical.
3. **ADD** attached Section 20 05 00 - Common Work Results for Mechanical.
4. **ADD** attached Section 20 05 03 - Existing Systems Work for Mechanical.
5. **ADD** attached Section 20 05 19 - Piping Specialties for Mechanical.
6. **ADD** attached Section 20 05 29 - Hangers and Supports for Mechanical.
7. **ADD** attached Section 20 05 30 - Sleeves and Seals for Mechanical.
8. **ADD** attached Section 20 05 48 - Vibration and Seismic Controls for Mechanical.
9. **ADD** attached Section 20 05 93 - Testing, Adjusting, Balancing for Mechanical.
10. **ADD** attached Section 20 07 00 - Mechanical Insulation.
11. **ADD** attached Section 22 11 00 - Facility Water Distribution.
12. **ADD** attached Section 22 13 00 - Facility Sanitary Sewerage.
13. **ADD** attached Section 22 40 00 - Plumbing Fixtures.
14. **ADD** attached Section 23 09 33 - Electric and Electronic Control System for HVAC.
15. **ADD** attached Section 23 09 93 - Sequence of Operation for HVAC Controls.
16. **ADD** attached Section 23 21 28 - HVAC Condensate Piping.
17. **ADD** attached Section 23 31 00 - HVAC Ducts and Casings.
18. **ADD** attached Section 23 33 00 - Duct Accessories.
19. **ADD** attached Section 23 37 00 - Air Outlets and Inlets.

20. **ADD** attached Section 23 72 23 - Heat Recovery Ventilator.
21. **ADD** attached Section 23 81 44 - Split System Heat Pump - Ductless.
22. **ADD** attached Section 23 81 45 - Split System Heat Pump - Ducted.
23. **ADD** attached Section 23 82 46 - Electric Heaters.

MECHANICAL DRAWINGS

1. Sheet M1-2 - Mechanical Schedules: **REPLACE** drawing with the attached revised Sheet M1-2.
2. Sheet M3-1 - Floor Plan - Plumbing: **REPLACE** drawing with the attached revised Sheet M3-1.
3. Sheet M4-1 - Floor Plan - HVAC: **REPLACE** drawing with the attached revised Sheet M4-1.
4. Sheet M4-2 - HVAC Details: **REPLACE** drawing with the attached revised Sheet M4-2.

ELECTRICAL DRAWINGS

1. Sheet E-001 - Legend, Notes & Abbreviations: **REPLACE** drawing with the attached revised Sheet E-001.
2. Sheet E-301 - Power Plan: **REPLACE** drawing with the attached revised Sheet E-301.
3. Sheet E-501 - Schedules & One-Line: **REPLACE** drawing with the attached revised Sheet E-501.

ATTACHMENTS

1. Mechanical Specifications Index, 1 page.
2. Section 20 02 00 - Operation and Maintenance Manual for Mechanical, 2 pages.
3. Section 20 05 00 - Common Work Results for Mechanical, 17 pages.
4. Section 20 05 03 - Existing Systems Work for Mechanical, 4 pages.
5. Section 20 05 19 - Piping Specialties for Mechanical, 3 pages.
6. Section 20 05 29 - Hangers and Supports for Mechanical, 8 pages.
7. Section 20 05 30 - Sleeves and Seals for Mechanical, 5 pages.
8. Section 20 05 48 - Vibration and Seismic Controls for Mechanical, 5 pages.
9. Section 20 05 93 - Testing, Adjusting, Balancing for Mechanical, 6 pages.
10. Section 20 07 00 - Mechanical Insulation, 6 pages.
11. Section 22 11 00 - Facility Water Distribution, 5 pages.

12. Section 22 13 00 - Facility Sanitary Sewerage, 6 pages.
13. Section 22 40 00 - Plumbing Fixtures, 5 pages.
14. Section 23 09 33 - Electric and Electronic Control System for HVAC, 6 pages.
15. Section 23 09 93 - Sequence of Operation for HVAC Controls, 3 pages.
16. Section 23 21 28 - HVAC Condensate Piping, 4 pages.
17. Section 23 31 00 - HVAC Ducts and Casings, 7 pages.
18. Section 23 33 00 - Duct Accessories, 4 pages.
19. Section 23 37 00 - Air Outlets and Inlets, 3 pages.
20. Section 23 72 23 - Heat Recovery Ventilator, 3 pages.
21. Section 23 81 44 - Split System Heat Pump - Ductless, 5 pages.
22. Section 23 81 45 - Split System Heat Pump - Ducted, 7 pages.
23. Section 23 82 46 - Electric Heaters, 3 pages.
24. Sheet M1-2 - Mechanical Schedules, 1 page.
25. Sheet M3-1 - Floor Plan - Plumbing, 1 page.
26. Sheet M4-1 - Floor Plan - HVAC, 1 page.
27. Sheet M4-2 - HVAC Details, 1 page.
28. Sheet E-001 - Legend, Notes & Abbreviations, 1 page.
29. Sheet E-301 - Power Plan, 1 page,
30. Sheet E-501 - Schedules & One-Line, 1 page.

END OF ADDENDUM

<u>DIVISION 20</u>	<u>GENERAL MECHANICAL</u>	
20 02 00	Operation and Maintenance Manual for Mechanical	2
20 05 00	Common Work Results for Mechanical	17
20 05 03	Existing Systems Work for Mechanical	4
20 05 19	Piping Specialties for Mechanical	3
20 05 29	Hangers and Supports for Mechanical	8
20 05 30	Sleeves and Seals for Mechanical	5
20 05 48	Vibration and Seismic Controls for Mechanical	5
20 05 93	Testing, Adjusting, Balancing for Mechanical	6
20 07 00	Mechanical Insulation	6
<u>DIVISION 22</u>	<u>PLUMBING</u>	
22 11 00	Facility Water Distribution	5
22 13 00	Facility Sanitary Sewerage	6
22 40 00	Plumbing Fixtures	5
<u>DIVISION 23</u>	<u>HEATING, VENTILATING, AND AIR CONDITIONING (HVAC)</u>	
23 09 33	Electric and Electronic Control System for HVAC	6
23 09 93	Sequence of Operation for HVAC Controls	3
23 21 28	HVAC Condensate Piping	4
23 31 00	HVAC Ducts and Casings	7
23 33 00	Duct Accessories	4
23 37 00	Air Outlets and Inlets	3
23 72 23	Heat Recovery Ventilator	3
23 81 44	Split System Heat Pump - Ductless	5
23 81 45	Split System Heat Pump - Ducted	7
23 82 46	Electric Heaters	3

SECTION 20 02 00
OPERATION AND MAINTENANCE MANUAL FOR MECHANICAL

PART 1 GENERAL

1.01 RELATED DOCUMENTS

- A. Drawings and general provisions of the Contract, including General and Supplementary Conditions and Division 00 and Division 01 Specification Sections, apply to this Section.
- B. Requirements of Section 20 05 00 apply to this Section.

1.02 WORK INCLUDED

- A. Operation and Maintenance Manual.

1.03 SUBMITTALS

- A. General: Comply with Section 20 05 00 and Division 01.
- B. Preliminary O&M: Submit preliminary review O&M manual for review.
- C. Final O&M: Submit Final O&M manuals per Division 01.

PART 2 PRODUCTS

2.01 GENERAL

- A. General Contents: A maintenance manual shall be compiled containing maintenance and operating information and maintenance schedules for all project mechanical systems. See Division 01 for quantities, organization, format, and other requirements; meet additional requirements as specified herein.

2.02 SUBMITTAL DATA AND TECHNICAL O&M DATA

- A. Submittal Data: Provide manufacturer's technical product data, with manufacturer's model number, description of the equipment, equipment capacities, equipment options, electrical power voltage/phase, special features, and accessories. Label equipment and fixtures data with same designation as used on contract documents. This information may consist of the same information as the submittal data (clearly identified and marked to suit each item). This information shall be provided for all items requiring maintenance and for items that may require replacement over a 30 year period or be revised due to an Owner building improvement.
- B. Technical O&M Data: Provide for each equipment or item requiring maintenance. Label O&M data to clearly indicate which equipment on the project it applies to (use same designation as used in the Contract Documents). Data to include:
 - 1. Manufacturer's operating and maintenance manuals and instructions.
 - 2. Itemized list of maintenance activities and their scheduled frequency.
 - 3. Maintenance instructions for each maintenance activity.
 - 4. Manufacturer's parts list.
 - 5. Manufacturer's recommended lubricants.
 - 6. Size, quantity and type of filters required (as applicable).
 - 7. Size, quantity and type each belts unit requires (as applicable).
 - 8. Size, quantity and type of fuses (as applicable)

- C. Sources: Provide names, addresses, and phone numbers for local manufacturer's representative, service companies, and parts sources for mechanical system components.
- D. Start-Up Reports: Include copies of all equipment and system start-up reports.
- E. Balancing Report: Include a full copy of the balancing report under a dividing tab for the specification section (or building system) where this work is specified. Where balancing is provided by others, obtain from the balancer a copy of the report to insert in the O&M's.

2.03 MAINTENANCE SCHEDULES

- A. General: Provide Maintenance schedules with an itemized list of maintenance activities and their scheduled frequency (i.e., weekly, monthly, semi-annually, etc.) for item requiring maintenance.
- B. Special Maintenance: List any critical maintenance items or areas requiring special attention.
- C. Start-Up/Shut-Down: Provide normal start-up, operating, and shut-down procedures; emergency shut-down procedures; and (where applicable) seasonal shut-down procedures.

PART 3 EXECUTION

NOT USED

END OF SECTION

SECTION 20 05 00
COMMON WORK RESULTS FOR MECHANICAL

PART 1 GENERAL

1.01 RELATED DOCUMENTS

- A. Drawings and general provisions of the Contract, including General and Supplementary Conditions and Division 00 and Division 01 Specification Sections, apply to this Section.
- B. Division 22 - Plumbing Systems.
- C. Division 23 - Heating, Ventilation, and Air Conditioning (HVAC) Systems.

1.02 WORK INCLUDED

- A. General Mechanical System Requirements.
- B. Mechanical System Motors.
- C. Identification and Labeling.

1.03 DEFINITIONS

- A. Abbreviations and Terms: Where not defined elsewhere in the Contract Documents, shall be as defined in RS Means Illustrated Construction Dictionary, Fourth Addition and in the ASHRAE Handbook of Fundamentals, latest edition.
- B. "As required" means "as necessary to form a safe, neat, and complete working installation (or product), fulfilling all the requirements of the specifications and drawings and in compliance with all codes."
- C. "Concealed" means "hidden from view" as determined when areas are in their final finished condition, from the point of view of a person located in the finished area. Items located in areas above suspended ceilings, in plumbing chases, and in similar areas are considered "concealed." Items located in cabinet spaces (e.g. below sinks) are not considered concealed.
- D. "Coordinate" means "to accomplish the work with all others that are involved in the work by: directly discussing the work with them, arranging and participating in special meetings with them to discuss and plan the work being done by each, obtaining and completing any necessary forms and documentation required for the work to proceed, reaching agreement on how parts of the work performed by each trade will be installed relative to each other both in physical location and in time sequence, exchanging all necessary information so as to allow the work to be accomplished with a united effort in accordance with the project requirements".
- E. "Finished Areas" means "areas receiving a finish coat of paint on one or more wall surface."
- F. "Mechanical", where applied to the scope of work, includes all project plumbing systems, HVAC systems, and controls for these systems and all work covered by specification Divisions 20, 22, and 23. Such work is shown on multiple drawings and is not limited to a particular set of sheets, or sheets prefaced with a particular letter.
- G. The term "related documents" (as used at the beginning of each specification section), and the Specification Divisions and Sections listed with it, is only an indication of some of the specification sections which the work of that section may be strongly related to. Since all items of work relate to one another and require full coordination, all specification sections, as listed in the Table of Contents, shall be considered as being "related documents", and shall be considered (by this reference) in the same manner as if they had all been listed under the term "related documents" in each specification section.

- H. "Work included" (as used at the beginning of each specification section), and the items listed with it, is only an indication of some of the items specified in that Section and is in no way limiting the work of that Section. See complete drawings and specifications for all required work.
- I. "Verify" means "Contractor shall obtain, by methods independent of the project Architect/Engineer and Owner, the information noted and the information needed to properly perform the work".
- J. "Substitution": As applied to equipment means "equipment that is different than the 'Basis of Design' equipment scheduled on the drawings (or otherwise indicated in the contract documents)". Where no manufacturer is specifically indicated, any of the Acceptable Manufacturers specified may be equally considered the "Basis of Design". As applied to products other than equipment it means "products that are different than the basis of design product, or by a manufacturer not listed as one of the Acceptable Manufacturers".

1.04 GENERAL REQUIREMENTS

- A. Scope: Furnish all labor, materials, tools, equipment, and services for all mechanical work. This section applies to all Division 20, 22, 23 specifications and to all project mechanical work. All mechanical equipment and devices furnished or installed under other Divisions of this specification (or by the Owner) which require connection to any mechanical system shall be connected under this division of the Specifications.
- B. General: All work shall comply with Division 00, General Conditions, Supplementary Conditions, Division 01, and all other provisions of the Contract Documents.
- C. Code:
 - 1. Compliance: All work shall be done in accordance with all applicable codes and ordinances. Throughout the Project Documents, items are shown or specified in excess of code requirements; in all such cases, the work shall be done so that code requirements are exceeded as indicated.
 - 2. Documentation: Maintain documentation of all permits and code inspections for the mechanical work; submit documentation showing systems have satisfactorily passed all AHJ inspections and requirements.
 - 3. Code Knowledge: Contractor and workers assigned to this project shall be familiar and knowledgeable of all applicable codes and ordinances. Code requirements are typically not repeated in the Contract Documents. By submitting a bid, the Contractor is acknowledging that the Contractor and workers to be utilized on this project have such knowledge.
 - 4. Proof of Code Compliance: Prior to final completion, satisfactory evidence shall be furnished to show that all work has been installed in accordance with all codes and that all inspections required have been successfully passed. Satisfactory evidence includes signed inspections by the local code authority, test lab results, qualified and witnessed field tests, and related acceptance certificates by local code authorities, and field notes by the Contractor as to when all inspections and tests occurred.
- D. Complete Systems: Furnish and install all materials, appurtenances, devices, and miscellaneous items not specifically mentioned herein or noted on the drawings, but which are necessary to make a complete working installation of all mechanical systems. Not all accessories or devices are shown or specified that are necessary to form complete and functional systems.
- E. Review and Coordination: To eliminate all possible errors and interferences, thoroughly examine all the Drawings and Specifications before work is started, and consult and coordinate with each of the various trades regarding the work. Such coordination shall begin prior to any work starting, and continue throughout the project.

- F. Conflicts and Discrepancies: Notify the Architect/Engineer of any discrepancies or conflicts before proceeding with any work or the purchasing of any materials for the area(s) of conflict until requesting and obtaining written instructions from the Architect/Engineer on how to proceed. Where conflicts occur, the most expensive and stringent requirement (as judged by the Architect/Engineer) shall prevail. Any work done after discovery of such discrepancies or conflicts and prior to obtaining the Architect/Engineer's instructions on how to proceed shall be done at the Contractor's expense.
- G. Drawings and Specifications: Drawings and specifications are complementary and what is called for in either is binding as if called for in both. The drawings are diagrammatic and show the general arrangement of the construction and therefore do not show all offsets, fittings and accessories which are required to form a complete and operating installation. Mechanical work is shown on multiple drawings and is not limited to a particular set of sheets, or sheets prefaced with a particular letter.
- H. Offsets/Fittings:
1. Piping Systems: Include in bid all necessary fittings and offset to completely connect up all systems, maintain clear access paths to equipment, and comply with all project requirements. Offsets are required to route piping around building structural elements, roof slopes, mechanical systems, electrical systems, and numerous other items. Due to the schematic nature of the plans such offsets are typically not shown. Contractor is responsible to determine the quantity of offsets and fittings required, and the labor involved. No added payment or "extras" will be granted for the Contractor's failure to correctly estimate the number of offsets and fittings and labor required. Contractor is advised that equipment and fixture connections may require more than 20 elbows per plumbing fixture and coil per pipe line.
 2. Duct Systems: Include in bid all necessary fittings, offsets, and transitions to completely connect all systems, maintain clear access paths, and comply with all project requirements. Offsets are required to route piping around building structural elements, roof slopes, mechanical systems, electrical systems, and numerous other items. Due to the schematic nature of the plans such offsets are typically not shown. Contractor is responsible to determine the quantity of offsets and fittings required, and the labor involved. No added payments or "extras" will be granted for the Contractor's failure to correctly estimate number of offsets, fittings, transitions and labor required. Contractor is advised that transitions are required at connections to all equipment, to all air inlets/outlets, crossing of beam lines, at crossing with piping, and similar locations.
- I. Design: The level of design presented in the documents represents the extent of the design being furnished to the Contractor; any additional design needed shall be provided by the Contractor. All design by the Contractor shall be performed by individuals skilled and experienced in such work, and where required by local code (or elsewhere in the documents) shall be performed by engineers licensed in the State where the project is located. Include in bid the costs of all such project design; including engineering, drafting, coordination, and all related activities and work. Such designs services are required for many building systems; including but not limited to ductwork at equipment, piping at fixtures and equipment, hanger/support systems, temporary duct/piping systems, mechanical offsets/adjustments to suit other system, and for methods/means of accomplishing the work.
- J. Special Tools: Furnish to the Owner one complete set of any and all special tools such as odd size wrenches, keys, etc. (allen wrenches are considered odd), which are necessary to gain access to, service, or adjust any piece of equipment installed under this contract. Each tool shall be marked or tagged to identify its use. Submit a written record listing the special tools provided, date, and signed by the Owner's representative receiving the tools.
- K. Standards and References: Shall be latest edition unless a specific edition, year, or version is cited, or is enforced by the AHJ.
- L. Warranties:

1. General: Products and workmanship shall be warranted to be free from all defects, capable of providing satisfactory system operation, and conforming to the requirements of the Contract Documents. Include in the project bid all costs associated with project warranties to ensure that the warranty extends for the required period; possible project delays and failure by others to complete their work may cause the start of the warranty period to be delayed. The Contractor shall be responsible for increasing the warranty dates by corresponding amounts to provide the required warranty periods.
2. Basic Project Warranty: As described in Division 00 and 01. See individual specification sections for specific warranty requirements. Start date and duration are as indicated in Division 00 and 01. Where not indicated otherwise in Division 00 or 01, the basic project warranty shall start at project substantial completion and be for one year.
3. Special Warranties: See individual specification sections for special warranty requirements and extended warranty periods beyond the basic project warranty.

M. Permits and Fees:

1. Obtain and pay for all permits, licenses, fees and inspections as required by the Code and as specified herein (unless noted otherwise).
2. Pay all charges made by any utility company or municipality for material, labor or services incident to the connection of service (unless noted otherwise).

1.05 SUBSTITUTIONS

- A. General: See Division 00 and 01 for information and requirements regarding substitutions. A substitution request form (see Division 01) is not required for manufacturers listed as "Acceptable Manufacturers".
- B. Redesign:
 1. The Contract Documents show design configurations based on particular manufacturers. Use of other manufacturers' equipment (i.e. substituted equipment) and products from what is shown (or specified) may require redesign of mechanical, plumbing, controls, fire protection, electrical, structural, and general building construction to accommodate the substitution.
 2. Review requirements for substitutions and provide redesign of all affected construction. The redesign shall be equal or superior in all respects to the Architect/Engineer's design (as judged by the Architect/Engineer), including such aspects as equipment access, ease of maintenance, duct connection locations, unit electrical requirements, noise considerations, unit performance, and similar concerns.
 3. Redesign shall be done by the Contractor and shall meet the requirements and have the approval of the Architect/Engineer prior to beginning work.
- C. Submittals: In addition to other required submittals, submit shop drawings showing the redesign for substituted equipment; submittal shall include installation plans and sections, connecting services (i.e. ducts, piping, electrical) locations and routing, required service clearances, and related installation details. Submit data required by other disciplines to allow review of the impact of the substitution (i.e. weights, electrical).
- D. Costs: Cost of redesign and all additional costs incurred to accommodate substituted equipment shall be borne by the Contractor.

1.06 QUALITY ASSURANCE

- A. Experience: All work shall be performed by individuals experienced and knowledgeable in the work they are performing, and experienced with the same type of systems and building type as this project. By virtue of submitting a bid, the Contractor is acknowledging that workers to be utilized on this project have such experience and knowledge. Upon request of the Engineer,

submit resumes showing the work history, training, and types of projects worked on, for individuals assigned to this project.

- B. Code: Utilize workers experienced and knowledgeable with codes pertaining to their work; verify code compliance through-out the project.
- C. ASME: All pressure vessels, pressure vessel safety devices, and pressure vessel appurtenances shall comply with the standards of, and bear the stamp of ASME.
- D. Quality Assurance Checks: Prior to ordering products and making submittals, confirm the following for each:
 - 1. General: Product is suitable for the intended purpose and complies with the Contract Documents.
 - 2. Manufacturer: Product's manufacturer is listed as an acceptable manufacturer in the Contract Document's or a substitution request (where allowed) has been submitted and the manufacturer has been listed as acceptable.
 - 3. Electrical (for products requiring electrical power):
 - a. Product is for use with the voltage/phase as indicated on the electrical plans (or for the electrical circuit the item will be connected to).
 - b. Product's ampacity requirements (MCA) do not exceed that indicated on the electrical plans (or for the electrical circuit the item will be connected to).
 - 4. Weight: Product's weight is no greater than that indicated.
 - 5. Space Verification: Product will fit in the space available, and along the path available to install the item, will have adequate service clearances, and will not impede on any clearances required for other items in the space the item will be located.
 - 6. Installation: A suitable method for installing the product has been selected which meets the project schedule and other requirements.
 - 7. Lead Time: The product's fabrication, shipping, and delivery period meets the project schedule requirements.
 - 8. Substituted Equipment: Where equipment is not the basis of design confirm all requirements for substituted equipment have been met and shop drawings of construction revisions have been (or are being) prepared.
 - 9. Controls: Item is compatible with the controls it will be connected to and has been coordinated with the firm providing the project control work.
- E. Check-Out: The Contractor shall be responsible to verify that proper installation and proper connections have been provided for all mechanical work. Contractor shall provide installation checkout, start-up services, and perform a thorough check of all mechanical systems to verify proper installation and operation. Contractor shall operate all items multiple times under varying conditions to confirm proper operation. Contractor shall submit a checklist listing all equipment, fixtures, and similar items furnished on this project, with a date and initials indicating when the item was checked, a list of what was checked, and by whom. Such check shall, as a minimum utilize documents provided by the equipment manufacturer. Such a check-out is in addition to any commissioning activities specified (unless noted otherwise).

1.07 SUBMITTALS - GENERAL

- A. Variations: Only variations that are specifically identified as described herein will be considered. Provide with the submittal (in addition to other information required): description of the proposed variation, entity who is proposing the variation, why the variation is being proposed, any cost changes associated with the variation, and any other pertinent data to allow for review. Failure to submit information on the variation as described will result in the submittal review being conducted without considering the variation.

- B. Quality Assurance: By submitting an item for review, the Contractor is claiming that all "Quality Assurance Checks" (see paragraph 1.06 this specification Section) have been performed and satisfactorily passed and no further comment from the submittal reviewer is required for the "Quality Assurance Checks".
- C. Product Submittals - Information Required:
1. Manufacturer's catalog information, containing product description, model number, and illustrations. Mark clearly to identify pertinent information and exact model and configuration being submitted.
 2. List of accessories and options provided with product.
 3. Product dimensions and clearances required.
 4. Product weight.
 5. Submittal identified with product name and symbol (as shown on the drawings or written in the specifications) and specification Section and paragraph reference.
 6. Performance capacity and characteristics showing compliance with the Contract Documents.
 7. Manufacturer's and local manufacturer's representative names, addresses, and phone numbers.
 8. For equipment requiring piping or duct connections:
 - a. Type of connections required.
 - b. Size and locations of connections.
 9. For electrically operated equipment:
 - a. Number and locations of electrical service connections required.
 - b. Voltage required.
 - c. Fuse or circuit breaker protection requirements.
 - d. Motor starter requirements; if motor starter is furnished with the equipment, submit product information on motor starter.
 10. For equipment requiring control connections:
 - a. Type of control signals required.
 - b. Control communication protocol.
 - c. Information on control devices furnished with equipment.
 - d. Location of control connections.
 11. Manufacturer's installation instructions.
 12. See each specification Section for additional submittal requirements.
- D. Shop Drawing Submittals: Provide for the following systems:
1. HVAC control systems.
 2. For any parts of any system which are to be installed differently than as shown on the drawings.
 3. Construction revisions to accommodate Substituted Equipment.
 4. Other areas/work as noted in the Contract Documents.
 5. For those systems requiring shop drawings, reference system's specification Section for additional requirements.

1.08 PRODUCT HANDLING, PROTECTION AND MAINTENANCE

- A. Protection:
 - 1. Protect all products from contamination, becoming unclean, and from damage of any kind and whatever cause; when being handled, in storage, and while installed, until final project acceptance.
 - 2. Completely cover fixtures, motors, control panels, equipment, and similar items to protect from becoming unclean and damage of any kind.
 - 3. Protect premises and work of other trades from damage due to Mechanical work.
- B. Openings: Cap all openings in pipe, ductwork and equipment to protect against entry of foreign matter until all work that could cause unclean conditions or damage is complete (including work that has dust or fumes associated with it). Caps shall be of sufficient strength and seal integrity to prevent entry of water or fumes for the most extreme conditions they may be exposed to (i.e. high velocity water spray, high winds, concrete splash, etc.)
- C. Storage: Provide properly conditioned and sheltered storage facilities for products to prevent damage of any kind and to maintain new condition. Provide adequate venting arrangements to avoid condensation damage.
- D. Operation and Maintenance:
 - 1. General: Inspect products periodically to confirm conditions and maintenance needs. Keep records of inspections and (upon request) forward to the Architect/Engineer prior to project final acceptance. Operation and Maintenance shall be in accordance with manufacturer's written procedures and recognized best maintenance practices. Keep records of maintenance and (upon request) forward to the Architect/Engineer prior to project final acceptance.
 - 2. Stored Products: Provide maintenance (i.e. equipment rotation, lubrication, flush, cleaning, etc.) and inspection on products while stored to maintain new condition.
 - 3. Installed Products: Provide maintenance and inspection of products and operate mechanical systems until substantial completion or specified Owner Instruction has been provided (whichever is later). Maintenance shall include all labor and materials and all manufacturers' recommended maintenance (i.e. strainer cleaning, filter changes, bearing lubrication, belt tensioning, etc.). In addition to scheduled maintenance, review all equipment periodically to allow detection of improper operation or any special maintenance needs; review shall be consistent with best practices for the product but in no case less than a site visit every two weeks. Document all maintenance activities.
- E. Damaged Products: Damaged products shall be replaced with new. Where damage is limited to paint (or similar finish), the product may remain if the finish is restored to a new condition (as judged by the Architect/Engineer).

1.09 ENGINEER REVIEWS AND WITNESSING

- A. General: Arrange construction schedule and notifications to the Engineer to accommodate Engineer's schedule and the possibility of review times occurring up to 14 days after notification, and for the possible failure to satisfactorily pass Engineer's reviews requiring revisions and re-reviews.
- B. Notification: Notify Engineer at least 7 days in advance of readiness for reviews; arrange mutually agreed upon times for the reviews to occur.
- C. Access: Provide ladders, any special tools and safety equipment to allow Engineer's access to areas and equipment. Remove and reinstall ceiling tiles, access panels, and similar items where requested to allow for reviews.
- D. Review of Systems with Equipment:

1. Prior to Engineer's review, system's equipment shall have received specified start-up and be substantiated by a written report.
 2. Prior to Engineer's review, systems shall have been operating properly for at least five consecutive days prior to the scheduled review date.
 3. Personnel shall be present to operate the system's equipment and controls, and to vary system settings as directed by the Engineer to allow for a review of operation over a range of settings.
- E. Re-Review Fees: The project budget allows for one review by the Engineer for specified reviews and witnessing. See Division 00 and 01 for compensation to the Engineer for required re-reviews.

1.10 REFERENCES

- A. ASME A13.1: Scheme for the Identification of Piping Systems.

PART 2 PRODUCTS

2.01 ACCEPTABLE MANUFACTURERS

- A. General: Any reference in the Specifications or on the Drawings to any article, device, product, material, fixture, form or type of construction by manufacturer, name, make, model number, or catalog number shall be interpreted as establishing a standard of quality and shall not be construed as limiting competition. The manufacturers listed as Acceptable Manufacturers may bid the project for the items indicated without submitting a substitution request.
- B. Substitutions: Other manufacturers desiring to bid the project require prior approval. See Division 01 for substitution requirements. In reviewing a manufacturer for acceptance, factors considered include: engineering data showing item's performance, proper local representation of manufacturer, likelihood of manufacturer's future local support of product, service availability, previous installations, previous use by Owner/Engineer/Architect, product quality, availability/quality of maintenance and operation data, capacity/performance compared to specified items, acoustics, items geometry and access, utility needs, and similar concerns.
- C. Limitations: The listing of a manufacturer as an Acceptable Manufacturer does not necessarily mean that the products of that manufacturer are equal to those specified. The listing is only an indication of those manufacturers which have represented themselves as being capable of manufacturing, or have in the past manufactured, items equal to those specified. The Architect/Engineer shall be the final judge as to whether an item is equal to that specified.
- D. Quality: Products provided by Acceptable Manufacturers shall be equal to or superior to the specified manufacturer's item in function, appearance, and quality, and shall fulfill all requirements of the Contract Documents. The Architect/Engineer shall be the judge as to whether an item meets these requirements or not.
- E. Manufacturer: To be considered as being made by a particular manufacturer, the product must be made directly by the manufacturer and have the manufacturer's name (or nameplate with name) affixed to the product (or on the product container where direct labeling is not possible). Example: manufacture "A" is listed as an acceptable manufacture; manufacturer "B" is not listed as an acceptable manufacturer; manufacturer "A" owns "B"; products from "B" do not qualify as being made by an acceptable manufacturer by virtue of ownership.

2.02 PRODUCTS - GENERAL

- A. Standard Products: Products shall be standard products of a manufacturer regularly engaged in the manufacture of such products. The standard products shall have been in satisfactory commercial or industrial use for two years prior to bid opening. The two year use shall include applications of equipment and materials under similar circumstances and of similar size. The

two year's experience must be satisfactorily completed by a product which has been sold or is offered for sale on the commercial market through advertisements, manufacturers' catalogs, or brochures. Except that equipment changes made solely to satisfy code requirements, to improve unit efficiency, or to comply with unique project requirements are not required to have two year prior operation.

- B. Latest Design: Products shall be the latest design and version available from the manufacturer, including software. Discontinued products shall not be used.
- C. Service Support: Qualified permanent service organizations for support of the equipment shall be located reasonably convenient to the equipment installation and able to render satisfactory service to the equipment on a regular and emergency basis during the warranty period of the contract.
- D. Manufacturer's Nameplate: Equipment shall have a manufacturer's nameplate bearing the manufacturer's name, address, model number, serial number, and additional information as required by code. Nameplate shall be securely affixed in a conspicuous place. The nameplate of the distributing agent will not be acceptable. Nameplate shall be of durable construction, easily read, with lettering minimum size 12 font.
- E. Compatibility: All components and materials used shall be compatible to the conditions and materials the items will be exposed to. All items exposed to the weather shall be galvanized, or be of stainless steel or similar corrosion resistant material.
- F. Sizes: Sizes indicated for products manufactured to standardized sizes (e.g. pipe, pipe fittings, valves, material gauges, etc.) are minimums. During bidding confirm that the sizes are available and meet project requirements. Where indicated sizes are not available provide the next larger available size; confirm this larger size will suit the construction and meet Contract Document requirements prior to ordering. Such size revisions are subject to Engineer's review; indicate size revisions on the product submittal and why the size is being revised.
- G. Non-Specified Items: Materials shown on the drawings but not specified shall be provided as shown and as required to suit the application illustrated and intended and shall be of commercial quality, consistent with the quality of similar type items provided on the project. Not all items shown on the drawings necessarily have a corresponding specification; such items shall be provided per this paragraph and so as to provide complete, finished, fully functioning mechanical systems.
- H. Weights: Do not exceed the weights shown unless added structural supports are provided. Such supports shall meet the requirements of the project Structural Engineer. The Contractor shall bear all costs for all redesign and added supports to accommodate heavier equipment. The Contractor shall reimburse the Engineer for all time associated with all review and analyses regarding the use of equipment heavier than that indicated.
- I. Temperature/Pressure Rating: All materials and components furnished shall be suitable for the temperature and pressures they will be exposed to. Contractor shall consider possible operating modes to ensure proper material ratings.
- J. Standardization: All products of the same type shall be by the same manufacturer and have the same characteristics and features to allow for Owner's standardization.
- K. Model Numbers: Any reference to a manufacturer's "model number" is a reference to a manufacturer's series number or type of product, and is not a complete "model number" in having all the necessary numbers/letters to convey all of the features, accessories, and options that are required. These series numbers are only meant to convey a type of product that may meet the project requirements. Where conflicts or discrepancies occur regarding a listed manufacturer's series or "model" number and specified capacities or features, the more stringent and expensive shall prevail.
- L. Lead Free: All solder, valve components, drinking fountain components, and other items in contact with potable water shall be lead free.

2.03 ELECTRICAL

- A. General: All electrical devices, wiring, products, and work shall comply with the Division 26 specifications and code. See drawings for building occupancy type, types of construction, and areas which may require special wiring methods or other electrical work.
- B. Equipment: All equipment requiring power shall be factory wired to an equipment mounted junction box (or an accessible compartment with power terminals or electrical device) arranged to allow for connection of electrical power.
- C. Overcurrent protection: Circuit breakers, circuit breaker disconnects, fuses, and other current limiting devices indicated to be provided, shall be rated to suit the maximum overcurrent rating of the item served, and have other ratings, as required by code. Circuit breakers for HVAC and refrigeration unit equipment shall be UL listed by HACR type.
- D. Fault Current AIC Rating: All equipment requiring the use of electrical power shall have a fault current rating complying with code. The minimum rating shall be 65,000 AIC; except where a lower fault current value is indicated on the drawings, or code allows uses of a lower number. Where the Contractor wishes to utilize equipment having fault current limitations lower than 65,000 AIC (or as shown on plans, whichever is less), the Contractor shall be responsible to provide suitable fusing, additional devices, and/or other changes to the building electrical system as necessary to accommodate the proposed equipment.
- E. Short Circuit Current Rating (SCCR): All equipment (or components) requiring the use of electrical power shall have a SCCR value to comply with code. The minimum rating shall be 22,000 Amps RMS Symmetrical unless a lower value is indicated on the plans or allowed by code. Where the Contractor wishes to utilize equipment having a lower rating, the Contractor shall be responsible to provide calculations substantiating that a lower SCCR is acceptable (and complies with code), or make system revisions to accommodate the proposed component.
- F. Product Certification (Listing): Products which require connection to electrical power shall be certified (i.e. listed) by a Nationally Recognized Testing Laboratory (NRTL) and be labeled (in a conspicuous place) with such certification (or certification mark). Certification shall comply with code, OSHA Standards, and Authority Having Jurisdiction (AHJ) requirements. NRTL's shall be recognized as such by OSHA and the AHJ. Certification shall be for the complete assembly (approval of individual components is not acceptable). Field evaluations to obtain certification shall be performed by accredited product testing laboratories acceptable to the AHJ and Engineer, be performed in accordance with code, NFPA 791, recognized practices, and be labeled to identify the certification. Certification is not required where the AHJ does not require it.

2.04 MOTORS

- A. General: Where a piece of equipment specified includes an electric motor, the motor shall be factory installed and mounted. Motor starters and motor electrical disconnect switches shall be provided by the Contractor doing the work of the Section where the item was specified, unless specifically shown to be provided by Division 26 (or another Division). Wiring from the motor to motor starters and to electrical disconnects shall be by the Contractor doing the work of the Section where the item was specified, unless specifically shown to be provided by Division 26.
- B. Acceptable Manufacturers: General Electric, TECO-Westinghouse, Reliance, Gould, Century, Baldor, U.S. Motors, Marathon, and acceptable manufacturers for the equipment (see individual specification sections).
- C. Type: Motor type shall comply with code and applicable standard requirements and be configured to suit the application. Motors located indoors shall be open frame, drip-proof type, unless indicated otherwise. Motors located outdoors exposed to weather shall have corrosion resistant finish and shall be totally enclosed fan cooled (TEFC) or totally enclosed non-ventilated (TENV) type, unless indicated otherwise.
- D. Listing: All motors shall be UL listed.

- E. Efficiency: Motor efficiencies shall comply with code. Fractional horsepower motors shall be the electronically commuted (EC) type with speed control where noted and where non-EC motors are not available which comply with code efficiency requirements. Motor power factor shall comply with code, local utility requirements, and as indicated. Provide added power factor correction devices as necessary to comply.
- F. Sizing: Motors shall not be smaller than indicated and of adequate size to start and drive the respective equipment when handling the quantities specified without exceeding the nameplate full load current at the conditions indicated and for the expected operating conditions. If it becomes evident that a motor furnished is too small to meet these requirements as a result of the Contractor using substituted equipment or having revised the system arrangement, the Contractor shall replace it with a motor of adequate size at no additional cost to the Owner. Contractor shall also arrange with the Electrical Contractor to increase the size of the wiring, motor starter and other accessories as required to serve the larger motor at no additional cost to the Owner.
- G. Service Factor: Minimum 1.15.
- H. EC Motors (ECM):
 - 1. General: Electronically commutated type with integral inverter to convert AC power (of voltage/phase indicated) to DC power, and solid state circuitry to vary output power and speed of motor. Motor shall have permanently lubricated bearings with an L10 life of 100,000 hours at expected operating conditions. Motor shall have rotor position and rotation detection as required for operation.
 - 2. Speed Range: Motor speed shall be controllable down to 25% of full speed.
 - 3. Manual Speed Control: Provide with manual speed adjustment dial for motor speed control. Dial shall be motor mounted unless indicated otherwise, operable by a screwdriver or by hand. Motor mounted controls shall be factory wired. Remote mount dials shall be hand operable (i.e. no tools required), shall be for mounting on a standard 2 x 4 electrical junction box, and be able to be located up to 100 feet remote from the motor. Motor control wiring for remote mount dials shall be factory wired from the motor to an equipment mounted junction box (with field supplied wiring from this J-box to the remote dial).

2.05 IDENTIFICATION AND LABELS

- A. General: All piping, valves, and mechanical equipment shall be labeled. Labels in concealed accessible spaces shall be reviewed and verified by Architect/Engineer prior to being concealed.
- B. Piping:
 - 1. Type: Self-sticking colored identification markers, lettered to identify the pipe contents, and banded at each end with arrow tape indicating the direction of flow. Markers shall be similar and equal to Brady "System 1" and Seton "Opti-Code" markers. Spray painted stencil labeling is not acceptable. Some labels may be special order.
 - 2. Identification Colors: Comply with ASME A13.1, and as follows:

<u>Conveyed Material/System</u>	<u>Background</u>	<u>Letters</u>
Potable Water	Green	White
Refrigeration	Black	White
 - 3. Lettering: Lettering shall identify the material conveyed in each pipe and shall match the designation used on the plans, but without abbreviations. Systems which have supply and return piping shall have piping labeled as such (i.e. heating water return, heating water supply, etc.). Systems that have different pressures shall be labeled to indicate such (i.e. Steam-Low Pressure, Steam- Medium Pressure, Natural Gas-Low Pressure, Natural Gas-Medium Pressure, etc.).

4. Size: Size of letters and color field shall comply with ASME A13.1, repeated here for convenience:

<u>Outside Diameter of Pipe or Covering</u>	<u>Length of Color Field</u>	<u>Size of Letters</u>
3/4 to 1-1/4 Inches	8 Inches	1/2 Inches
1-1/2 to 2 Inches	8 Inches	3/4 Inches
2-1/2 to 6 Inches	12 Inches	1-1/4 Inches
8 to 10 Inches	24 Inches	2-1/2 Inches
Over 10 Inches	32 Inches	3-1/2 Inches

5. Applications: Install on all exposed piping adjacent to each shut-off valve, at branches to indicate changes of direction, where pipes pass through walls and floors, on 20 foot centers or at least one in each room on each pipe. Markers shall be installed on all concealed accessible piping (i.e., piping above suspended ceilings, behind access doors, in accessible chases, etc.) near the point of access. For piping above suspended ceilings, markers shall be installed the same as if the piping was exposed (i.e., same as if the suspended ceiling was not in place). Markers shall be installed so as to be easily read by a person standing on the floor. Provide additional flow arrows at each pipe connection at valves having more than 2 ports (i.e. 3-way control valves).
6. Other Requirements: See other specification Sections for additional requirements.

C. Valves:

1. Labels: Laminated plastic or phenolic material, at least 1/16-inch thick, with black surface layer and white (unless other color indicated) sub-layer for letter engraving to expose sub-layer. Labels shall not be less than 3" x 1" in size. Label shall be pre-drilled at one end for attachment to valve. Attach to valve with No. 6 polished nickel-steel jack chain of sufficient length to allow label to hang free.
2. Lettering: Engrave label with valve size, name of system served (cold water, heating water supply, chilled water supply, etc.) and purpose of valve. Lettering size 3/16-inch, except where needed to be smaller to fit label size.
3. Application: Labels shall be installed on all valves except valves at hydronic system coils and equipment where the valve purpose is readily obvious.

D. Equipment:

1. Labels: Laminated plastic (or phenolic) material, 1/16-inch thick, with black surface layer and white (unless other color indicated) sub-layer, with engraving through to expose white sub-layer. Minimum 2-inch high (unless indicated otherwise or required due to equipment size) with length to contain required lettering. Label shall be pre-drilled and be mechanically fastened to the equipment. Prior to making labels, submit a list of all proposed labels.
2. Lettering: All caps, engraved on label, with equipment designation (same designation as used on Contract Drawings; e.g. HVAC-101, EF-22, CP-1A). Air handling equipment (i.e. VAV terminal units, fans, etc.) labels shall include the room names and numbers or area of building served (use final installed room designations). Where systems serve portions of the building (i.e. wings or floors), include on label the area served. Lettering shall be in multiple rows, with equipment label on top row. Equipment lettering to be 5/8-inch high; area served lettering to be 3/8-inch high (except that smaller lettering may be used if necessary to fit label size).
3. Application: All scheduled mechanical equipment shall be labeled. The label shall be located on a side of the equipment so as to be easily read, with the marking visible to a person standing at the access level near the equipment (assuming any necessary access to a concealed unit has been made).

E. Duct Access Doors:

1. Labels: Minimum 1-inch high (unless indicated otherwise) lettering, engraved on laminated plastic or phenolic material, at least 1/16th inch thick. Laminated plastic (or phenolic) shall have red surface layer and white (unless other color indicated) sub-layer, with engraving through to expose white sub-layer. Label shall be pre-drilled and be mechanically fastened to the duct access door. In lieu of laminate type, self-adhesive vinyl signs may be used.
2. Lettering: Label shall comply with code, and indicate the item being accessed (i.e. Fire/Smoke Damper, Fire Damper, CO2 Sensor, etc.). Labels shall include the room names and numbers or area of building served; use final installed room designations.
3. Application: All duct access doors serving fire dampers, fire/smoke dampers, smoke dampers, control dampers, items required by code, and control devices shall be labeled where these items are provided under Division 26, they shall be labeled by Division 26. Access door label is not required where it is readily obvious as to what is being accessed (e.g. duct coil where coil is easily seen). The label shall be located so as to be easily read, with the marking visible to a person standing at the access level near the access door (assuming any necessary access to a concealed label has been made).

PART 3 EXECUTION

3.01 GENERAL

- A. Workmanship: Furnish and install products to provide complete and functioning systems with a neat and finished appearance. If, in the judgment of the Architect/Engineer, any portion of the work has not been installed in accordance with the Contract Documents and in a neat workmanlike manner, or has been left in a rough, unfinished manner, the Contractor shall be required to revise the work so that it complies with the Contract Documents, at no increase in cost to the Owner.
- B. Coordination: Coordinate the work with all trades that may be affected by the work to avoid conflicts and to allow for an organized and efficient installation of all systems.
- C. Examination and Preparation: Examine installation conditions and verify they are proper and ready for the work to proceed. Verify compatibility of materials in contact with other materials, and suitability for conditions they will be exposed to. Do not proceed with the work until unsatisfactory conditions have been corrected. Prepare area to accept the work and prepare products for the installation.
- D. Field Conditions: Check field conditions and verify all measurements and relationships indicated on the drawings before proceeding with any work. In verifying existing conditions, the Contractor shall verify by direct physical inspection, complete tracing out of systems, by applying test pressures, by excavation and inspection, use of pipeline cameras, and other suitable absolute certain methods to confirm the actual physical conditions that exist.
- E. Openings and Cutting and Patching in New Construction:
 1. Openings - General: The General Contractor shall provide all required spaces and provisions in structures of new construction for the installation of work of all other contractors or subcontractors.
 2. Coordination: The Contractors doing work subject to Division 20 shall furnish to the General Contractor (in a timely manner) all needed dimensions and locations of openings to allow for these openings to be provided as the construction adjacent to the opening is being done.
 3. Cutting and Patching: Cutting and patching of structures in place made necessary to admit work, repair defective work, or by neglect of contractors and subcontractors to properly anticipate their requirements, shall be done by the General Contractor at the expense of the contractors or subcontractors responsible. Work shall be done in a

fashion to duplicate the results that would have been obtained had the work been properly sequenced.

4. Patching Materials: Patching shall be with materials of like kind and quality of the adjoining surface by skilled labor experienced in that particular trade.
- F. Cleaning: Clean all products (whether exposed to view or not) of all construction debris, and other materials; grease and oil spots shall be removed with appropriate cleaning agents and surfaces carefully wiped clean. Where cleaning cannot restore items to new conditions, the item shall be replaced with new.
- G. Underground Work: All trenching, backfilling, compacting, and similar groundwork for utilities shall comply with specification, code, manufacturer, best construction practices, and WSDOT Standard Specifications for Road, Bridge, and Municipal Construction. Provide minimum 6-inch deep sand bedding, minimum 6-inch thick surrounding sand backfill, and 6-inch deep compacted backfill at buried items, unless noted otherwise or required otherwise. Washed 3/8-inch minus pea gravel may be used where allowed by product manufacturer and code. Subsequent backfill shall be in 6-inch lifts, and be compacted to 95% maximum density. Backfill material (above initial 6-inch sand) shall be free of organic material, and rocks larger than 3-inches in any direction.

3.02 INSTALLATION

- A. General: Work shall be in accordance with manufacturer's written installation instructions, code, applicable standards, and best construction practices.
- B. Space Verification: Prior to ordering materials verify that adequate space exists to accept the products, and along the installation path. Such verification shall be by direct field measurement of the actual space available and use of manufacturer's final submittal dimensions. Where the project involves new construction and long lead items and a time schedule not allowing for such direct field measurements, confirm in writing with all trades associated with building the space that adequate room is available. Review maintenance and service access space required and confirm requirements will be met. No submittals shall be made until such space verification work has been performed, and confirmed that adequate space is available. By virtue of making a submittal that Contractor affirms he has completed this verification.
- C. Installation Locations: Unless dimensioned locations for items are shown, select the precise location of the item in accordance with the Contract Documents, coordinated with other trades and item connection locations, and subject to the Architect/Engineer's review. No allowances will be granted for failure to obtain the Architect/Engineer's review, failure to coordinate the work, and failure to comply with Contract Document requirements.
- D. Replacement and Maintenance: Install mechanical equipment to permit easy access for normal maintenance, and so that parts requiring periodic replacement or maintenance (e.g. coils, heat exchanger bundles, sheaves, filters, bearings, etc.) can be removed. Relocate items which interfere with access or revise item installation location, orientation, or means of access.
- E. Building Access Doors: Provide access doors where indicated and where needed to provide access to valves, drains, duct access doors, and similar items requiring service or access that would otherwise be inaccessible. Consult architectural drawings and coordinate location and installation of access doors with trades which are affected by the installation. Access doors are typically not shown on the drawings. The Contractor shall review all construction details and types and locations of items requiring access to determine quantity and sizes of access doors required.
- F. Manually Operated Components: Valves, damper operators, on/off switches, keypads, controls, and other devices which are manually adjustable or operated shall be located so as to be easily accessible by a person standing on the floor. Any such items which are not in the open shall be made accessible through access doors in the building construction. See individual specification sections for additional requirements.

- G. Monitoring Components: Gauges, thermometers, instrumentation, and other components which display visual information (i.e. operating conditions, alarms, etc.), shall be located and oriented so as to be easily read by a person standing on the floor. Provide necessary brackets, hangers, remote read devices and accessories as needed. Equipment control panels and graphic displays furnished with equipment (or integral to equipment) shall be located to be easily accessible by a person standing on the floor adjacent to the equipment, and be located between 4-feet and 6-feet above the finished floor.
- H. Accessible Installation: If circumstances at a particular location make the accessible installation of an item difficult or inconvenient, the situation shall be discussed with the Architect/Engineer before installing the item in a location that will result in poor access.
- I. Rotating Parts: Belts, pulleys, couplings, projecting setscrews, keys and other rotating parts which may pose a danger to personnel shall be fully enclosed or guarded in accordance with Code, and so as not to present a safety hazard.
- J. Equipment Pads: All ground and slab mounted mechanical equipment shall be installed on a minimum 4-inch thick concrete pad, (unless indicated otherwise). Where the largest dimension for any pad exceeds 6 feet provide a 6 x 6 - 10 gauge welded wire fabric reinforcement in the pad (unless noted otherwise).
- K. Dissimilar Metals: Provide separations between all dissimilar metals. Where not specified in another way, use 10 mil plastic tape wrapped at point of contact or plastic centering inserts.
- L. Electrical Offsets: Provide offsets around all electrical panels (and similar electrical equipment) to maintain space clear above and below electrical panels to structure, and clearance of 3.5 feet directly in front of panel, except where indicated otherwise or required by code to be more. Such required offsets are typically not shown on the plans but are to be provided per this paragraph. Include in bid offsets for all systems near electrical panels.
- M. Piping Through Framing: Piping through framing shall be installed in the approximate center of the member. Where located such that nails or screws are likely to damage the pipe, a steel plate at least 1/16-inch thick shall be installed to provide protection. At metal framing, wrap piping to prevent contact of dissimilar metals. At metal and wood framing, provide plastic pipe insulators at piping penetrations through framing nearest each equipment connection and on at least 32-inch centers.
- N. Safety Protection: All ductwork, piping and related items installed by this Contractor that present a safety hazard (i.e., items installed at/near head height, items projecting into maintenance access paths, etc.) shall be covered (at hazardous area) with 3/4" thick elastomeric insulation and reflective red/white self-sticking safety tape. All sharp corners on supports and other installed items shall be ground smooth.
- O. Equipment Access: Access to equipment is of utmost importance. Contractor shall apply extra attention to the location of pipe and duct routings and in coordinating all work so that equipment access and a clear maintenance pathway to equipment is maintained. Poor maintenance access will not be accepted.
- P. Pressure Tests: Maintain documentation of all pressure (and leakage) tests performed on systems and submit with project closeout documents. Records shall contain (as a minimum): date of test, system name, description portion of system being tested, method of test, initial and final test pressures (or of measured leakage rates, as applicable), indication of test pass or fail, name and signature of individual performing (or documenting) the test, initials of independent witness of test.

3.03 PAINTING

- A. General: Painting shall comply with Division 09 specifications regarding painting. Colors, in all cases, shall be as selected by the Architect/Engineer. Color samples shall be submitted to the Architect/Engineer for approval prior to painting.

- B. The following painting shall be provided under Division 20: The inside of all ductwork (including visible dampers, roof vents, insulation pins, and any visible metal) behind grilles, registers, diffusers, and louvers shall be painted flat black.

3.04 PENETRATION PROTECTION

- A. Exterior and Watertight Penetrations: Where any work pierces the building exterior (or construction intended to be watertight) the penetration shall be made watertight and weatherproof. Provide all necessary products (e.g. caulking, flashing, screens, gaskets, backing materials, siding, roofing, trim, etc.). Where not detailed or indicated how to install submit shop drawings of the proposed methods. Flashing arrangements shall be per SMACNA Architectural Sheet Metal Manual unless noted otherwise. Caulking alone is not an acceptable means of sealing penetrations.
- B. Equipment: Equipment or products located outdoors shall be watertight (except for provisions designed to intentionally accept water and having drain provisions) and shall be designed and intended by the manufacturer to be used outdoors at the project location. Where any work pierces the unit casing exposed to the outdoors the penetration shall be made watertight and weatherproof; provide all necessary products (e.g. caulking, flashing, gaskets, backing materials, etc.).

3.05 START-UP

- A. General: Provide inspections, start-up and operational checks of all mechanical systems and equipment. Maintain documentation of all start-up work and submit with project closeout documents. See individual specification Sections for additional requirements.
- B. Personnel: Inspection and start-up services shall be done by individuals trained in the operation, and knowledgeable with, the systems being started-up. Equipment start-up shall be by the manufacturer's authorized service representative where indicated (see individual specification Sections).
- C. Scheduling and Agenda: Submit a proposed detailed start-up schedule with proposed dates and times at least 30 days prior to the earliest proposed system start-up. Revise dates and times as mutually agreed upon with trades involved, and witnesses, before submitting a final start-up schedule.
- D. Witnessing: Start-up may be witnessed by the Engineer and Owner's representative (at their option). Notify the Engineer and Owner 7 days prior to the proposed start-up time.

3.06 OWNER INSTRUCTION

- A. General: Provide instruction to the Owner on the operation and maintenance of all installed mechanical systems.
- B. Personnel: Instruction on the operation and maintenance of products shall be by individuals trained and experienced in the installation, operation and maintenance of these products. Instruction shall be by the product manufacturer's authorized service representative where indicated (see individual specification Sections).
- C. Scheduling and Agenda: Submit a proposed instruction schedule (with proposed dates and times) and an instruction agenda at least 30 days prior to the earliest proposed instruction period. Coordinate Owner and Architect/Engineer review and arrange mutually agreed upon instruction schedule and the instruction agenda, and submit a final instruction schedule and agenda. Organize instruction by sub-systems corresponding to the project specifications (or similar logical grouping).
- D. Instruction: Demonstrate and explain normal start-up, normal shut-down, normal operation, normal settings, adjustments, signs of abnormal operation, emergency shut-down, safety concerns, and related information. Demonstrate and explain system maintenance requirements with references to the O&M Manual. Show how maintenance is performed,

including how items are accessed, maintenance procedures, tools and parts required, and related information. Review typical repairs and explain how performed.

END OF SECTION

SECTION 20 05 03
EXISTING SYSTEMS WORK FOR MECHANICAL

PART 1 GENERAL

1.01 RELATED DOCUMENTS

- A. Drawings and general provisions of the Contract, including General and Supplementary Conditions and Division 00 and Division 01 Specification Sections, apply to this Section.
- B. Requirements of Section 20 05 00 apply to this Section.

1.02 WORK INCLUDED

- A. Protection of Items from Damage.
- B. Maintaining Utilities and Building Services.
- C. Cleaning.
- D. Review of Existing Conditions.
- E. Utility Locate.
- F. Cutting and Patching.
- G. Deactivation and Cap-off of Systems.
- H. Salvage and Reinstallation.

1.03 DEFINITIONS

- A. "Remove", "demo", and "demolish" mean "Remove and legally dispose of item and item accessories; except where indicated to be reinstalled, salvaged, or some other required work is indicated."
- B. "Salvage and Reinstall (or Reinstallation)" means to "carefully remove, clean, pack for movement (drain of fluids, seal and protect from damage) and relocate to Contractor's selected (and suitable) storage area; reinstall as indicated after other work has been completed and as required by project schedule."

PART 2 PRODUCTS

2.01 GENERAL

- A. Materials: All materials used for capping, temporary piping, repairs, reconnecting, reinstalling, and related work shall be same as specified for new systems.

PART 3 EXECUTION

3.01 GENERAL

- A. Protection: Existing items not being demolished shall be protected against damage. Where necessary to prevent damage or necessary to accomplish other work, items shall be disconnected and moved to a suitable protective storage location during the project and then reinstalled to their original location.
- B. Utilities and Building Systems: Maintain existing utilities and building systems in service (unless indicated otherwise) and protect from damage during project. Where utilities or building systems must be shut-off to accomplish the work, see drawing notes, Section 20 05 00, and

Division 01 for downtime limitations and Owner coordination and notification requirements; coordinate interruptions with other trades.

- C. Cleaning: All existing items that remain during construction and were affected by the construction shall be cleaned to a like new condition.
- D. Equipment and System Contents: Equipment and systems contain fluids that are typical for such items (e.g. HVAC units contain refrigerant, oils; hydronic systems contain ethylene glycol, corrosion control chemicals, etc.) and require special removal methods and disposal.
- E. Existing Items:
 - 1. Information and Field Verification: Routing, locations, and identification of existing items on plans are approximate and are limited. The relative location of systems shown on plans has not been verified, and is schematic only. Field verify locations, contents, and flow direction of all piping and ducts prior to performing any work associated with such systems (see also Section 20 05 00). Do not rely on existing labeling of systems; such labeling shall be considered wrong until verified by other physical evidence.
 - 2. Work Around: Existing building cavities (ceiling spaces, walls, etc.) contain a multitude of systems (e.g. conduit, wiring, fire suppression, light fixtures, low voltage system components, piping, ducts, etc.) typical for buildings of the type of this project. Added effort is required to identify and locate these systems, to work around such systems, and to temporarily disconnect and reconnect (and possibly remove and store) various building components to accommodate the work. Existing building elements will also require the work to be installed in smaller sections (i.e. shorter pipe or duct lengths) than normally possible, and to make system connections in awkward or cramped locations.
 - 3. Revisions: Revise existing systems as needed to accommodate project work and new finishes. Work shall include adjusting locations of items to suit new ceiling heights, revisions to building element locations, revisions to finishes, and other changes.
 - 4. Electrical: Verify voltage, phase, horsepower, panel circuits, and other electrical parameters of existing items prior to beginning work and ordering replacement products. Electrical data listed on the drawings for such items has not been field verified.
 - 5. Controls: Verify existing communication protocol, existing component manufacturers, and model numbers, LAN type(s), software, location of devices, quantity of system points, methods used in terminating communication wiring, overall system performance, and sequences.
- F. Cutting: Provide all cutting and openings as necessary to accomplish the work indicated. No structural members shall be cut unless Structural Engineer's approval is obtained first. Assume all building members are "structural" unless clearly evident otherwise. See Section 20 05 00 and Division 01 for additional requirements.
- G. Patching: Patch all wall/floor/ceiling/roof openings left by removal of existing items where wall/floor/ceiling/roof is to remain. Patch with materials and workmanship so as to match finish of adjacent undisturbed area, and to provide conditions equivalent to the original new construction.
- H. Disposal: Dispose of all demolished items and all waste materials off site in accordance with code and legal requirements.

3.02 REVIEW OF EXISTING CONDITIONS

- A. General: Provide field investigation of all systems and existing conditions to confirm extent of demolition, routing of existing systems, existing building materials of construction, mechanical system types and materials involved, areas where cutting and patching is required, site access, sizes of existing system components, and all other aspects of existing building and systems and their relationship to the Work.

- B. Review Timing: Review existing conditions prior to bidding, again prior to commencing any work or ordering materials, and continually throughout the project.
- C. Review for Space and Routing:
 - 1. Review existing conditions (including dimensions) where equipment must be moved through to confirm adequate space and path.
 - 2. Review existing conditions (including dimensions and locations of existing systems) where work will occur to determine impact on the locations and routing of new systems; include time to develop shop drawings and revisions to routing shown on the design drawings to accommodate existing conditions.
- D. Existing Record Drawings: Existing record drawings located at the Engineers office or Architect's office are available for review.
- E. Construction Thickness: Where needed to perform the work, and to prevent damage to adjacent construction, verify the thickness of existing concrete floors and other elements by selective drilling or saw cutting.

3.03 EXISTING CONSTRUCTION

- A. Existing Invert Elevations: For bidding purposes, assume that the invert elevation (i.e.) of all underground piping is 6 feet below finish floor (or existing grade for piping outside the building) at work location (unless noted otherwise). Verify depth before beginning work.
- B. Concrete Slabs: All slab on grade concrete floors shall be assumed to be 8" thick, with #4 rebar reinforcement 12" O.C. each way (unless noted otherwise). All upper floors shall be assumed to be 8" thick with #4 rebar 24" O.C. each way (except where existing drawings indicate otherwise).
- C. Ceiling Construction: All ceiling construction shall be assumed to be two layers of 5/8" type X GWB installed over 2 x 6 20 gauge steel stud framing on 16" centers (unless noted otherwise).
- D. Wall Construction: All walls shall be assumed to be constructed of 8 x 16 solid grouted CMU (unless noted otherwise).

3.04 DEMOLITION

- A. General: Review site conditions and identify all demolition work; include in bid all costs for demolition and disposal. Coordinate all demolition work with other trades. Confirm items to be salvaged or reused, and overall demolition scope.
- B. Scope: Not all items to be demolished are necessarily shown on the drawings, but are covered by notes and specifications. In addition to demolishing items indicated, demolish all associated items (unless indicated otherwise); this includes such items as supports, insulation, piping, drains, control wiring/conduit, power wiring/conduit, unions, valves, and similar accessories. Demolish all utilities serving demolished items completely or back to active mains where mains are to remain active; assume such utilities extend at least forty feet from the demolished items (unless indicated otherwise). Demolish all mechanical items located in building elements which are being demolished (i.e. located in walls, chases, roof assemblies, etc.). Demolish items as required to accomplish the work.
- C. Prevent Damage: Where existing building systems are to be reused to serve new items, carefully execute the demolition work to prevent damage to items to be reused and to prevent the demolition of items that are intended for reuse.
- D. Depth: Abandoned items, anchors, inserts, and other projections embedded in existing construction and not being concealed by new construction shall be removed to 1" below the adjacent finished surface, and the disturbed area patched.
- E. Cap-Offs and Terminations:

1. Permanent: Provide cap-off of all existing utilities and systems that are cut or served demolished items. All cap-offs shall occur in concealed locations (unless indicated otherwise). Cap-off's shall be of equivalent material as the item being capped and be insulated where the connected system was insulated or where doing so will reduce energy consumption or prevent condensation.
2. Temporary: Provide temporary cap-off of all existing utilities and systems to allow continued use of all systems until the final system components are installed and connected.
3. Wiring Terminations: Terminate all control wiring and electrical power connections in a manner that complies with code and allows remaining items to function as intended.

3.05 REUSED AND SALVAGED ITEMS

- A. General: Where indicated to be reused or salvaged, comply with the following.
- B. Removal: Carefully remove items to prevent damage and in a manner to allow for reinstallation. Remove all related items to the extent needed to allow for project work.
- C. Clean: Clean item and all accessories to like new condition.
- D. Package: Package item to allow for transport and storage without damaging. Label packaging to identify contents; include unique identifier number, brief description, and location (room number) item was removed from.
- E. Documentation: Compile a list of all salvaged items and documentation to allow for their reuse.
- F. Storage: Store items in secure and protective area until Owner (or project) is ready to receive.
- G. Reuse: For items indicated to be reused:
 1. Reinstall items and accessories as completion of other work allows. Provide all necessary connections and services to allow item to function properly; not all such connections are illustrated on the plans.
 2. Provide new fasteners, supports, anchors, gasketing, seals, pipe connectors, unions and related items to allow for complete and proper connections and operation of reinstalled items.

END OF SECTION

SECTION 20 05 19
PIPING SPECIALTIES FOR MECHANICAL

PART 1 GENERAL

1.01 RELATED DOCUMENTS

- A. Drawings and general provisions of the Contract, including General and Supplementary Conditions and Division 00 and Division 01 Specification Sections, apply to this Section.
- B. Requirements of Section 20 05 00 apply to this Section.

1.02 WORK INCLUDED

- A. Unions.
- B. Flexible Connectors.
- C. Access Doors.

1.03 SUBMITTALS

- A. General: Comply with Section 20 05 00.
- B. Product Data: Submit product information data for all items to be used.

1.04 REFERENCES

- A. ASME B16.18: Cast Copper Alloy Solder Joint Pressure Fittings.
- B. ASME B16.39: Malleable Iron Threaded Pipe Unions: Classes 150, 250, and 300.
- C. IFGC: International Fuel Gas Code.
- D. IMC: International Mechanical Code.
- E. UPC: Uniform Plumbing Code.

1.05 GENERAL REQUIREMENTS

- A. Domestic (Potable) Water Systems: All items in contact with potable water shall be lead free in accordance with ANSI/NSF 61. Plastic piping system components shall comply with ANSI/NSF 14.
- B. System Requirements: Products shall comply with additional requirements cited for the specific systems the products are being installed in; see specific system specification sections.

PART 2 PRODUCTS

2.01 ACCEPTABLE MANUFACTURERS

- A. Products shall comply with Section 20 05 00, Paragraph 2.01, Acceptable Manufacturers.
- B. Unions: Anvil, Nibco, Watts, Epco, Victaulic, Ward, Jefferson Union.
- C. Dielectric Connectors: Victaulic Precision Plumbing Products, Elster Perfection.
- D. Flexible Connectors: Universal, Mason, Dormont, OPW, Unisource, Twin City Hose.
- E. Access Doors: J.R. Smith, Zurn, Josam, Acudor, Elmdoor, Kees, J.C. Industries.
- F. Escutcheons: Selected by Contractor.

2.02 UNIONS

- A. Dielectric Unions: Shall not be used. Provide "dielectric connector" with standard union where union is required at connection point of dissimilar materials.
- B. Unions on Copper Pipe:
 - 1. General: Pressure and temperature ratings to match (or exceed) piping system being installed in; minimum Class 125.
 - 2. 2-Inch Pipe and Smaller: Wrought copper solder joint copper to copper union, complying with ASTM B16.18.
 - 3. 2-1/2-Inch Pipe and Larger: Brass flange unions.
- C. Unions on Steel Pipe:
 - 1. General: Pressure and temperature ratings to match (or exceed) piping system being installed in; minimum Class 150.
 - 2. Threaded: Malleable iron union, threaded connections, with ground joints, complying with ASME B16.39. Provide with brass-to-iron seat (except provide iron-to-iron seat where the conveyed material is detrimental to brass).
 - 3. Welded and Flanged: Flange unions; see individual system specification sections.
- D. Dielectric Connector: Schedule 40 steel pipe nipple, zinc electroplated, with internal thermoplastic lining which is NSF/FDA listed and meeting all code requirements for potable water applications. Suitable for continuous use up to 225 deg F and 300 psi. "Clearflow" dielectric waterway (or approved). For systems operating at temperatures greater than 225 deg F provide flanged connections with insulating gaskets.

2.03 ACCESS DOORS

- A. Hinged lockable steel access door, for mounting on face of wall, with minimum 16 gauge frame and 16 gauge door, concealed hinge, cam and cylinder lock, and anchor straps or anchor frame with mounting holes. Provide Type 304 stainless steel construction with No. 4 finish where used in restrooms, locker rooms, kitchens, and similar "wet" areas. Provide steel construction with prime coated finish in other areas. Door shall have rounded corners, and concealed pivoting rod hinge. Size shall be 12" x 12" (unless indicated otherwise) but shall be large enough to allow necessary access to item being served and sized to allow removal of the item (where access door is the only means of removal without disturbing fixed construction).
- B. Fire Rating: Door shall maintain fire rating of element installed in; reference drawings for required rating.
- C. Access doors shall all be keyed alike. Provide two (2) keys for each door.

2.04 ESCUTCHEONS

- A. Type: Circular metal collar to seal pipe penetrations at building elements (i.e. walls, floors, cabinets, and ceilings); one piece type except that split hinge type may be used for applications on existing piping.
- B. Construction: Constructed of chrome plated brass or polished stainless steel, sized to tightly fit pipe exterior surface (or pipe insulation where insulated) and to fully cover the building element penetration.
- C. Projection: Shallow face type with maximum projection from wall not to exceed 1.2 times inner diameter of escutcheon.
- D. Special Applications: For sprinkler heads and similar special applications see items' specification Section.

PART 3 EXECUTION

3.01 INSTALLATION

- A. Unions: Install unions in pipe connections to control valves, coils, regulators, reducers, all equipment, and where it may be necessary to disconnect the equipment or piping for repairs or maintenance; and as indicated. Where flanged connections occur at equipment additional unions are not required unless indicated otherwise. Dielectric unions shall not be used.
- B. Dielectric Connectors: Install connectors between all connections of copper and steel piping (or equipment), and other dissimilar metals. Where flanged connections occur use insulating type flanges. Dielectric unions shall no be used.
- C. Access Doors: Provide access doors where indicated on the drawings and where needed to provide access to trap primers, water hammer arresters, cleanouts, valves, coils, controls, mechanical spaces, and similar items requiring service or access that would otherwise be inaccessible. Consult architectural drawings and coordinate location and installation of access doors with trades which are affected by the installation. Access doors are typically not shown in the plans. Review ceiling and wall types and locations of items requiring access to determine quantity and sizes of access doors required.
- D. Escutcheons: Provide at all pipe penetrations through building elements, except where penetration is concealed (unless specifically noted otherwise). Items located in accessible cabinet spaces (e.g. below sinks) are not considered concealed.

END OF SECTION

SECTION 20 05 29
HANGERS AND SUPPORTS FOR MECHANICAL

PART 1 GENERAL

1.01 RELATED DOCUMENTS

- A. Drawings and general provisions of the Contract, including General and Supplementary Conditions and Division 00 and Division 01 Specification Sections, apply to this Section.
- B. Requirements of Section 20 05 00 apply to this Section.

1.02 WORK INCLUDED

- A. Pipe Hangers and Supports.
- B. Duct Hangers and Supports.
- C. Mechanical Equipment Anchors and Supports.

1.03 QUALITY ASSURANCE

- A. Pipe Hanger Standards: Manufacturers Standardization Society (MSS) Standards SP-58, SP-89, SP-69, and SP-90.
- B. General: All methods, materials and workmanship shall comply with Code; including IBC, IMC, UPC, NFPA Standards, and ASME standards.

1.04 SUBMITTALS

- A. General: Submittals shall comply with Section 20 05 00.
- B. Product Data: Submit product data for all hangers, supports, and anchors. Data to include finish, load rating, dimensions, and applicable agency listings. Indicate application for all items by system type, size, and other criteria as appropriate to project.
- C. Shop Drawings:
 - 1. General: Shop drawings shall clearly indicate dimensions, anchor and support type, anchor and support size, anchor and support spacing, finish, configuration, and systems/equipment to be applied to.
 - 2. Attachments: Submit shop drawings for proposed attachment methods to building structure where the method of attachment has not been shown on the drawings, or where attachment methods other than those shown on the drawings are desired to be used.
 - 3. Fabricated Supports: Submit shop drawings for all fabricated supports.
 - 4. Finished Areas: Submit shop drawings for all supports that will be exposed in finished areas.

1.05 REFERENCES

- A. ADC: Air Duct Council - Flexible Duct Performance and Installation Standard, 5th Edition.
- B. ASHRAE-F: American Society of Heating, Refrigeration, and Air Conditioning Engineers, Handbook of Fundamentals.
- C. ASME B31.1: Power Piping.
- D. ASME B31.9: Building Services Piping.
- E. ASTM A36: Standard Specification for Carbon Structural Steel.

- F. ASTM A108: Standard Specification for Steel Bar, Carbon and Alloy, Cold - Finished.
- G. ASTM A123: Standard Specification for Zinc (Hot-Dip Galvanized) Coatings on Iron and Steel Products.
- H. ASTM A153: Standard specification for Zinc Coating (Hot-Dip) on Iron and Steel Hardware.
- I. ASTM A653: Standard Specification for Steel Sheet, Zinc Coated (Galvanized) or Zinc Iron Alloy-Coated (Galvannealed) by the Hot Dip Process.
- J. ASTM A907: Standard Specification for Steel, Wire, Epoxy - Coated.
- K. ASTM A924: Standard Specification for General Requirements for Steel Sheet, Metallic-Coated by the Hot Dip Process.
- L. IBC: International Building Code.
- M. IMC: International Mechanical Code.
- N. Mason SRG: Mason Industries Seismic Restraint Guidelines for Suspended Piping, Ductwork, Electrical Systems and Floor Mounted Equipment, 6th Edition.
- O. MSS SP-58: Pipe and Hangers and Supports - Materials, Design and Manufacture.
- P. MSS SP-69: Pipe and Hangers and Supports - Selection and Application.
- Q. MSS SP-89: Pipe Hangers and Supports - Fabrication and Installation Practices.
- R. MSS SP-90: Guidelines on Terminology for Pipe Hangers and Supports.
- S. SMACNA-DCS: HVAC Duct Construction Standards Metal and Flexible, 3rd Edition.
- T. SMACNA SRM: Seismic Restraint Manual Guidelines for Mechanical Systems, 2nd Edition.
- U. UPC: Uniform Plumbing Code.

PART 2 PRODUCTS

2.01 ACCEPTABLE MANUFACTURERS

- A. Products shall comply with Section 20 05 00, Paragraph 2.01, Acceptable Manufacturers.
- B. Hangers and Supports: Grinnell, B-Line Systems, Unistrut, Erico, PHD, Basic-PSA, Pate, Caddy, Unisource, Metraflex.
- C. Anchors: Rawplug, Phillips, Hilti, Michigan, Simpson, Fastenal, Grinnell, B-Line Systems, Unistrut, PHD, Basic-PSA, Metraflex.

2.02 GENERAL

- A. Finish:
 - 1. Indoor Applications: Electro-plated zinc in accordance with ASTM B 633, or hot-dip galvanized after fabrication in accordance with ASTM A 123; except that hanger straps may be formed from pre-galvanized steel.
 - 2. Outdoor Applications: Hot-dip galvanized after fabrication in accordance with ASTM A 123, ASTM A 153, or ASTM A 653 (as applicable to item).
- B. Identification: Steel pipe hangers and supports shall be stamped with the manufacturer's name, part number, and size.
- C. Hanger Rods: Threaded hot rolled steel. Hanger rods shall be sized so that the total load imposed (including pipe or duct, insulation, hangers, and fluid) does not exceed the following:

<u>Nominal Rod Diameter</u>	<u>Maximum Load</u>
1/4 Inch	240 Pounds
5/16 Inch	440 Pounds
3/8 Inch	610 Pounds
1/2 Inch	1130 Pounds
5/8 Inch	1810 Pounds
3/4 Inch	2710 Pounds
7/8 Inch	3770 Pounds
1 Inch	4960 Pounds

- D. Hanger Straps: Galvanized steel, minimum 1" x 22 gauge (except where required by Code to be heavier or noted otherwise), of lock-forming grade conforming to ASTM A924, G90 (minimum) galvanized coating conforming to ASTM A 653. Minimum yield strength of 30,000 psi. Straps shall be sized so that the total load imposed does not exceed the following:

<u>Strap Size</u>	<u>Maximum Load</u>
1" x 22 Gauge	230 Pounds
1" x 20 Gauge	290 Pounds
1" x 18 Gauge	380 Pounds
1" x 16 Gauge	630 Pounds
1-1/2" x 16 Gauge	990 Pounds

- E. Beam Attachments: Constructed of malleable iron or steel, MSS standard types designed for clamping to building structural support beam. "C" clamp type shall have cup point set screws with locknuts and retaining straps. Center loaded type beam clamps shall have horizontally adjustable clamping bolt (or rod with nuts).
- F. Concrete Anchors: Wedge type expansion anchors, with hex nut and washer, and stainless steel split expansion rings. Tested to ASTM E 488 criteria, UL listed, with exposed anchor head stamped with code to identify anchor length.
- G. General Anchors (Screws, Nuts, Bolts, Fasteners):
1. General: Constructed of materials suitable for the conditions exposed to and materials being joined, with minimum 50 year service life. Stainless steel construction where exposed to corrosive conditions. Configuration, size and grade to suit application, accommodate expected forces, and provide anchoring to structural element (or allow for proper fastening of items). Minimum safety factor of 2.5 (or as required by code, whichever is greater). Comply with ASTM A307, SAE J429, SAE J78, or ASTM A 563; bolts and nuts shall have unified inch screw threads (course, UNC).
 2. Test Reports: Provide independent test report indicating fastener strength (pullout and shear) as installed in the materials and applications of this project.
 3. Finish: In finished areas, the portion of fastener exposed to view shall match the exposed finish of item being fastened.
- H. Manufactured Strut Systems:
1. Channels: Minimum 12 gauge, 1-5/8 x 1-5/8" (unless noted otherwise), with slots/holes to suit application.
 2. Accessories: Channel nuts press formed, machined and hardened with gripping slot, fabricated from steel conforming to ASTM A 108 or ASTM A 36. Fittings fabricated from steel in accordance with ASTM A 907.
- I. Steel: Structural steel per ASTM A 36.
- J. Wood: Only allowed to be used where building structural elements are of wood construction and where located within building construction (e.g. in walls); fire treated. Where located outdoors shall be the pressure treated type; with all cut portions of wood painted with wood preservative.

- K. Field Galvanizing Compound: Brush or spray applied galvanizing treatment; consisting of a premixed ready to apply liquid organic zinc compound, with 95% metallic zinc content by weight in dry film. ZRC worldwide "ZRC Cold Galvanizing Compound".

2.03 PIPE HANGERS AND SUPPORTS

- A. Copper Pipe: All hangers used directly on copper pipe shall be copper plated or have a factory applied 1/16-inch thick (minimum) plastic coating on all contact surfaces.
- B. Cushion Clamps: Pipe clamps with a vibration dampening insert between the pipe and clamp, with a nylon inserted lock-nut on clamp. Insert shall be constructed of a thermoplastic elastomer, designed to tightly fit and match pipe size and clamp used with; suitable for system temperatures.
- C. Type: Shall be MSS type selected in accordance with MSS-69; except that MSS type 24, 26, and 34 shall not be used.
- D. Trapeze Hangers: Shall be constructed of carbon steel angles, manufactured strut channels, or other structural shapes with flat surface (or installed saddle) for pipe support. Provide steel washer where hanger rod nuts bear on trapeze hanger. Pipe anchors shall be two piece clamp type designed for use with trapeze style (i.e. inserted into strut channel opening) or one piece type designed for welded or bolted attachment to trapeze; shaped to match pipe size (or pipe size plus insulation thickness on insulated systems). Pipe guides shall comply with paragraph titled "Alignment Guides"; or be steel angles with vertical leg height equal to pipe diameter (or pipe diameter plus insulation thickness on insulated systems); or be two piece clamp type pipe anchors sized and installed to serve as a guide.
- E. Insulated Pipe Supports:
 - 1. Insulation material at pipe support shall consist of expanded perlite, calcium silicate or high density phenolic. Insert shall have a flame resistant jacket of nylon reinforced kraft paper bonded to aluminum foil cover on insulation, with sheet metal shield. Insulation material shall have no more than 5% deformation at 100 psi and a thermal conductivity no more than 0.32 Btu/hr-sf-deg F-inch. Insulation shall be suitable for temperatures and conditions it will be exposed to without degradation over a 30 year life.
 - 2. All insulation and materials shall have a fire hazard rating not to exceed 25 for flame spread and 50 for smoke development, as tested by ASTM E84.
 - 3. Insert shall be same thickness as adjoining pipe insulation, sized to match pipe used on.
 - 4. Minimum insulation and shield lengths, and shield gauge:

Nominal Pipe Diameter <u>In Inches</u>	Insulation Length <u>In Inches</u>	Shield Length <u>In Inches</u>	Minimum Shield <u>Gauge</u>
1/2 to 1	*	4	20
1-1/4 to 3-1/2	6	4	18
4 to 5	9	6	18
6 to 10	9	6	16

* Insert not required; shield at insulation is acceptable.

2.04 DUCT HANGERS AND SUPPORTS

- A. Hangers: As shown in SMACNA-DCS except that wire shall not be used and all materials used shall comply with these specifications.
- B. Vertical Duct Supports at Floor: 1-1/2" x 1-1/2" x 1/8" (minimum) galvanized steel angle and to support ducts, maximum 12 foot on center, and as shown in SMACNA-DCS. For ducts over 30 inches wide provide riser reinforcing with hanger rods between the riser support and riser reinforcing.

- C. Vertical Duct Supports at Wall: 1-1/2" x 1/8" (minimum) strap or 1-1/2" x 1-1/2" x 1/8" (minimum) angle bracket and as shown in SMACNA-DCS.
- D. Hanger Attachments to Structure: As shown in SMACNA-DCS to suit building construction and as allowed on structural drawings. Provide washers at all fasteners through hanger straps (regardless of SMACNA-DCS allowances). Where C-clamps are provided, retainer clips shall be used. Friction beam clamps shall not be used.
- E. Hanger Attachments to Ducts: As shown in SMACNA-DCS except that wire shall not be used as any form of support or attachment for ducts.
- F. Flexible Duct Strap: Woven polypropylene hanging strap, minimum tensile strength of 400 lbs, minimum 1.75-inches wide, designed and intended for flexible duct support.
- G. HVAC Support Wire: Steel, minimum 12 gauge, soft-annealed wire, complying with Federal Specification QQ-W-461H, and IBC for support of ceilings and accessories installed in ceilings.

PART 3 EXECUTION

3.01 INSTALLATION - GENERAL

- A. General: Provide all necessary bolts, nuts, washers, fasteners, turnbuckles, hanger rods, rod connectors, stanchions, wall/roof/floor backing and attachments, bridging between structural members, and any other miscellaneous accessories required for the support and anchoring of all pipes, ducts, and mechanical equipment. All supports, whether from floor, walls, or hung from structure, are Contractor's responsibility. Anchors and supports shall be adequate to accommodate forces equipment will be exposed to. Any field cut pieces of galvanized materials shall be hot-dip galvanized after cutting; or be solvent and wire brushed clean and receive field applied galvanizing treatment. Field applied galvanizing shall be multiple coats to provide as near equal protection as possible to factory (or hot-dip) applied coatings.
- B. Backing: Install steel or wood backing in walls (anchored to studs) and in ceiling (anchored to joists or trusses), as required to provide support for items.
- C. Installation: Install all inserts, anchors, and supports in accordance with manufacturer's instructions, code requirements, and best professional practices. The most restrictive criteria governs.
- D. Welded Assembly Finish: All welded steel support assemblies shall have a power wire brush and primer paint finish.
- E. Attachments: Attach to building structure (or concrete pads) as shown on drawings (reference structural drawings). Where not detailed on the drawings, the Contractor shall design and submit shop drawings of proposed attachment methods to the Engineer for review.
- F. Support Spacing: Maximum spans between supports may be significantly less than the maximum spans allowed by code due to structural limitations of allowable loads on building members, fastener limitations, or other considerations. The most restrictive criteria governs; reference structural drawings.
- G. Application:
 - 1. Where not detailed on the drawings (or otherwise indicated), the selection and design of supports is the Contractor's responsibility, in compliance with code and Contract Document requirements; subject to submittal review and acceptance by the Engineer.
 - 2. Exposed supports in finished areas shall be arranged to minimize their visibility; be free of dents, scratches and labels, and be configured in a manner to match the decorum and finish of the room they are installed in. Exposed supports in finished areas shall be cleaned to allow for field painting (unless a chrome, stainless steel, or similar finish has been indicated).

3. HVAC Support wire and flexible duct strap shall only be used for support of ceiling air inlets and outlets, or at flexible duct supports.
- H. Seismic: Provide hangers, supports, anchors and bracing as required by code and as necessary to accommodate forces in a seismic event. Seismic bracing is not required for piping sized 2-inch and less, or for horizontal piping where the distance from the top of the pipe to the support attachment point to the building structure is less than 12-inches (unless noted otherwise). Seismic bracing is not required for ductwork less than 28-inch in diameter or having across sectional area less than 6 square feet, or for horizontal ductwork where the distance from the top of the duct to the support attachment point to the building structure is less than 12-inches (unless noted otherwise). All equipment shall be seismically anchored.
- I. Building Structural Loads: Where installed items incur loads that exceed the buildings structural capacity (i.e., roof or wall carrying capacity as indicated on the drawings or otherwise noted in the documents), provide support types to transmit the loads to floors or other parts of structure that can carry load (e.g. bridging between joists to distribute load, added structure between walls to allow walls to carry load, etc.). Such supports shall consist of all welded steel angle iron supports, pipe columns, or similar custom fabricated items. Provide with base plates, U bolts, or similar type accessories to allow proper anchoring and seismic hold-down for all items supported.

3.02 INSTALLATION OF PIPE HANGERS AND SUPPORTS

- A. General: Aboveground pipe shall be anchored to the structure to prevent sagging, to keep pipe in alignment, and to resist the forces the pipe will be exposed to; piping shall be supported independent of equipment so that no loads bear on the equipment.
- B. Adjustment: All pipe supports shall be provided with a means of adjustment for the aligning and leveling of the pipe after installation.
- C. Applications: Selection, sizing, and installation of pipe supports and accessories shall be in accordance with the manufacturers recommendations, standards MSS SP-89 and MSS SP-69, UPC, and IMC. Refrigerant piping and similar piping subject to vibration (i.e. high pressure tubing) shall be installed with cushion clamps.
- D. Support Spacing: Provide piping support spacing according to the most restrictive of the following: UPC, IMC, ASME B31.1, B31.9, local codes, manufacturers recommendations or Contract Documents specific requirements. Provide supports at each change in direction of piping and at each side of concentrated loads (such as in-line pumps, valves greater than size 5", and similar items). On hubless cast iron piping provide supports at each branch connection; and hubless cast iron piping greater than size 2" shall have supports on both side of piping couplings.
- E. Trapeze Hangers: Four or more pipes running parallel may be supported on trapeze hangers provided the slopes of such pipes allow use of common trapeze. Suspend trapeze hanger from the building structure using hanger rods; attach to the building structure using concrete inserts, beam clamps, or other approved methods. Where trapeze width exceeds 30 inches, and where building attachment restrictions require more anchor points, provide three (or more) hanger rod supports. Provide pipe anchors to secure piping to trapeze on minimum 20 foot spacing; size and install pipe anchor to allow longitudinal movement of pipe (unless noted otherwise) with minimal vertical and transverse movement; where pipe is subject to expansion/contraction provide anchoring and alignment guides per paragraph titled "Thermal Expansion/Contraction".
- F. Vertical Piping Supports: Support piping at each floor line with pipe clamps and at intermediate points as required so that hanger spacing does not exceed allowable spacing and as required to prevent excessive pipe movement and so as to comply with the maximum spacings cited above. Support all pipe stacks at their bases with a concrete pier or suitable support. For vertical pipe drops which occur away from a wall or similar anchoring surface, provide angled bracing from nearest structure on two sides of drop to provide rigid anchoring of pipe drop. Provide riser clamps and vertical supports on all vertical vent piping where the vertical pipe length exceeds 5'.

- G. Pre-Insulated Pipe Supports: Protect all insulated pipe at point of support with pre-insulated pipe supports. Such supports shall be in place at time of installing pipe.
- H. Underground Pipe: Shall be evenly supported on approved bedding materials, as appropriate for the type of piping being used.

3.03 INSTALLATION OF DUCT HANGERS AND SUPPORTS

- A. General: Provide anchors and supports for all ductwork. Supports and hangers shall comply with SMACNA-DCS, except that hanger spacing and hanger maximum loads shall be governed by whichever is more restrictive between these specifications or SMACNA-DCS.
- B. Hanger Spacing -- Rectangular Duct:

<u>Duct Area</u>	<u>Maximum Spacing</u>
Up to 4 Square Feet	8 Feet
4.1 to 10 Square Feet	6 Feet
10 Square Feet and Up	4 Feet
- C. Hanger Spacing -- Round Duct:

<u>Duct Area</u>	<u>Maximum Spacing</u>
Up to 24 Inch Diameter	8 Feet
25 Inch to 48 Inch Diameter	6 Feet
49 Inch Diameter and Up	4 Feet
- D. Hanger Spacing - Flexible Duct: 4 feet, and at changes of direction as needed to maintain duct elevation and smooth airflow.
- E. Vertical Ducts: Support at each floor level, but in no case less than on 12 foot intervals.
- F. Flexible Duct: Support with methods shown in ADC. Metal strap in contact with the flexible duct shall have minimum 1.5-inch width.
- G. Fittings: Provide supports at each change in direction of duct for ducts with 4 square foot area or more, or for ducts larger than 24 inch diameter. Locate hangers at inside and outside corners of elbows--or at each end of fitting on each side.
- H. Concentrated Loads: Provide additional supports at each side concentrated loads such as modulating dampers (24" x 24" and larger), duct heaters (18" x 18" and larger), sound attenuators (all sizes), and similar items.
- I. Exterior Duct: Provide supports for exterior ductwork as shown in SMACNA-DCS; spacing as specified herein.
- J. End of Duct: At end of duct run, hangar shall be located no more than 1/2 the allowed hangar spacing from the end of the run.

3.04 CEILING SERVICES

- A. Less than 20 Pounds: Ceiling mounted services, air inlets/outlets, and accessories weighing less than 20 pounds shall be positively attached to the ceiling suspension main runners (or ceiling support members) or to cross runners with the same carrying capacity as the main runners (or support members).
- B. 20 to 56 Pounds: Ceiling mounted services, air inlets/outlets, and accessories weighing 20 pounds but not more than 56 pounds, in addition to the above, shall have two No. 12 gauge wire hangers (or minimum 1" x 22 gauge hangar straps) connected from the terminal or service to the ceiling system hangers or to the structure above. These added hangers may be slack.
- C. Greater Than 56 Pounds: Ceiling mounted services, air inlets/outlets, and accessories weighing more than 56 pounds shall be supported directly from the building structure by approved hangers.

3.05 MECHANICAL EQUIPMENT ANCHORS AND SUPPORTS

- A. General: Provide anchoring and supports for all mechanical equipment. All equipment shall be anchored to (or supported from) the building structure. In lieu of anchoring to the building, anchor outdoor equipment to the concrete pad serving the equipment.
- B. Suspended Equipment: Support as indicated on the plans. Where not indicated use the methods shown (or consistent with) Mason SRG and SMACNA-DCS; submit shop drawings of the proposed methods to the Engineer for review.
- C. Roof Mounted Equipment: Install on roof curbs or roof sleepers as indicated. Anchor equipment to the curb (or sleeper), with the curb (or sleeper) in turn anchored to the building structure.
- D. Vibration Isolation: Equipment shall be supported and anchored in such a way so that no equipment vibration is transmitted to the building structure.
- E. Seismic: Provide anchors and bracing to resist seismic forces.

END OF SECTION

SECTION 20 05 30
SLEEVES AND SEALS FOR MECHANICAL

PART 1 GENERAL

1.01 RELATED DOCUMENTS

- A. Drawings and general provisions of the Contract, including General and Supplementary Conditions and Division 00 and Division 01 Specification Sections, apply to this Section.
- B. Requirements of Section 20 05 00 apply to this Section.

1.02 WORK INCLUDED

- A. Pipe Sleeves.
- B. Duct Sleeves.
- C. Duct Closure Collars.
- D. Non-Firestop Seals.

1.03 DEFINITIONS

- A. Rated Assembly: Wall, floor, roof, ceiling, roof/ceiling or other construction which is required (by code or the Contract Documents) to have a fire-resistance rating or to be a smoke barrier.

1.04 SUBMITTALS

- A. General: Shall comply with Section 20 05 00.
- B. Product Data: Provide product data on all material to be use. Provide MSDS for all sealants, caulks and similar materials.
- C. Shop Drawings – General: Shop drawings of proposed sealing/flashing assembly for roof and exterior wall penetrations.

1.05 REFERENCES

- A. ASTM A 36: Standard Specification for Carbon Structural Steel.
- B. ASTM C534: Standard Specification for Preformed Flexible Elastomeric Cellular Thermal Insulation in Sheet and Tubular Form.
- C. SMACNA-DCS: SMACNA HVAC Duct Construction Standards, Third Edition.
- D. SMACNA-ARCH: SMACNA Architectural Sheet Metal Manual, Seventh Edition.
- E. USGBC LEED: US Green Building Council LEED Reference Guide for Green Building Construction.

1.06 GENERAL REQUIREMENTS

- A. Corrosion Protection: All sleeves exposed to water, moisture, chemicals, or subject to corrosion shall be constructed of corrosion resistant materials suitable for the exposure. Steel sleeves shall be hot dip galvanized after assembly. Provide additional coatings as noted or as required to resist corrosion.

PART 2 PRODUCTS

2.01 ACCEPTABLE MANUFACTURERS

- A. Products shall comply with Section 20 05 00, Paragraph 2.01, Acceptable Manufacturers.
- B. Non-Firestop Seal Materials: 3M, GE, Dow Corning, Tremco, Pecora, Sonneborn, Pipeline Seal & Insulator.

2.02 PIPE SLEEVES

- A. Diameter:
 - 1. Belowground: Inside diameter of belowground pipe sleeves shall be at least 2 inch larger than the outside diameter of the pipe or pipe covering (for covered piping systems), so as to allow free movement of piping.
 - 2. Aboveground: Inside diameter of aboveground pipe sleeves shall be at least 1-inch larger than the outside diameter of the pipe or pipe covering (for covered piping systems), so as to allow free movement of piping.
 - 3. Large Movement: Provide larger sleeves where a larger space around pipe exterior is required by code, where specifically noted, where expansive soils or other unusual conditions are present and where required to accommodate large piping movement.
- B. Length: Horizontal sleeves through finished areas (where sleeve is exposed to view) shall be sized to be flush with finished surfaces; other horizontal sleeves may terminate flush to 2-inches past the element being penetrated. Vertical sleeves shall be sized to extend one inch above the final floor elevation.
- C. Structural Type: Fabricated from schedule 40 steel pipe. Waterstop shall consist of fully welded 2-inch larger diameter collar, minimum 1/4 inch thick steel, located on sleeve so as to be centered within the element being penetrated. Provide waterstop on sleeves where sleeves are installed in the following locations: in cast-in-place concrete, where any part of the sleeve ends are exposed to water, where installed in floors with water-proofing or water stopping membranes, in rooms with floor drains, and where needed for anchoring/support purposes. Prime paint all surfaces with rust-inhibiting paint.
- D. Aboveground Type: Fabricated from 18 gauge galvanized sheet metal or 22 gauge spiral seam galvanized steel duct. Provide with galvanized steel angle tabs, collars, or similar to allow for anchoring where sleeve cannot be retained in place by element being penetrated.
- E. Flexible Type: Flexible cellular elastomeric insulation, complying with ASTM C 534, Type 1, minimum 1/2-inch thick. Water vapor permeance shall not exceed 0.08 perms. Operating Temperature Limits -20 degrees F to 180 degrees F. Provide in sheet or pre-fabricated pipe size; provide multiple wraps as required.

2.03 DUCT SLEEVES

- A. Size: Inside dimension of duct sleeves shall be at least 1-inch larger than the outside dimension of the duct or duct covering (for covered duct systems). For duct system conveying air or gases operating above 200 deg F provide sleeve dimension minimum 2-inch larger than duct or duct covering (for covered duct systems). Provide larger sleeves where a larger space around duct exterior is required by code, by duct or flue system manufacturer, to provide required thermal clearances, where specifically noted, where unusual conditions are present and where required to accommodate large movement.
- B. Length: Horizontal sleeves through finished areas (where sleeve is exposed to view) shall be sized to be flush with finished surfaces; other horizontal sleeves may terminate flush to 2-inches past the element being penetrated. Vertical sleeves shall be sized to extend one inch above the finished floor.

- C. Structural Type: Fabricated from schedule 40 steel pipe for round openings and 3" x 3" x 3/8" welded steel angles for other openings (unless noted otherwise). Prime paint all surfaces with rust-inhibiting paint.

2.04 DUCT CLOSURE COLLARS

- A. General: Closure collars shall provide closure of opening between duct and opening in element penetrated and shall abut tight up to and overlap duct and shall consist of rolled angle material (for round ducts) and welded framed angles (for rectangular and round ducts).
- B. Size: Closure collars shall be sized to match duct and opening applied to and shall have minimum 2-inch overlap on duct side and 2-inch overlap at opening/penetrated element side but shall completely cover opening in element penetrated with minimum 1-inch overlap to undisturbed element (i.e. wall, floor, etc.).
- C. Material: Closure collars shall be fabricated of 20 gauge galvanized steel for ducts 15 inches diameter and less and shall be fabricated of 18 gauge galvanized steel duct for all larger ducts and all square and rectangular ducts.

2.05 NON-FIRESTOP SEALS

- A. Indoor Sealants:
 - 1. Dry Areas: Single component, latex sealant complying with requirements of ASTM C834. Sealants shall be of the following types, or approved equal:
 - a. Tremco Corporation "Tremflex 834".
 - b. Pecora Corporation "AC-20 Arylic Latex".
 - c. Sonneborn Building Products "Sonolac".
 - 2. Wet Areas: Single component, mildew resistant silicone sealant complying with requirements of ASTM C920, Type S, Grade NS, Class 25. Color white. Sealants shall be of the following types, or approved equal:
 - a. Dow Corning "786 Mildew Resistant Silicone".
 - b. Pecora Corporation "898 Silicone Sanitary Sealant".
 - c. Tremco "Tremsil 200".
- B. Outdoor Sealants:
 - 1. General: Single component, non-sag, low modulus, silicone elastomeric sealant conforming to requirements of ASTM C920, Type S, Grade NS, Class 100/50. Sealant shall be of the following types, or approved equal.
 - a. Dow Corning "790 Silicone Building Sealant".
 - b. Pecora Corporation "890 Silicone".
 - c. Tremco "Spectrem 1".
- C. Expanding Foam Sealant:
 - 1. General: Single component, polyurethane insulating sealant with flame spread index of 25 or less and smoke development rating of 50 or less. Shall expand and fully cure within 24 hours to a semi-rigid, closed cell, water and air resistant foam. Sealant shall be of the following types, or approved equal.
 - a. DAP "Kwik Foam".
 - b. Fomo Products "Handi-Foam".
 - c. Todol Products "EZ Flo Gun Foam".
- D. Link Seal: Seals shall consist of interlocking synthetic rubber links shaped to continuously fill the annular space between the pipe and wall opening. The seal assembly shall expand when

mechanically tightened to provide an absolute water-tight seal between the pipe and wall opening. Sizing shall be per manufacturer's recommendations. Seal shall be Pipeline Seal and Insulator, "Link-Seal" (or approved).

- E. Specialty: Packed fiberglass or wool insulation; with silicone sealant rated for use with temperatures and other conditions encountered.

PART 3 EXECUTION

3.01 PIPE SLEEVES

- A. General: Provide sleeves for all piping passing through walls, floors, partitions, roofs, foundations, footings, grade beams, and similar elements. Except that sleeves are not required at core drilled penetrations through solid concrete or where formed openings equivalent to a core drilled opening are provided. Sleeves shall be the following type (horizontal/vertical refer to position of sleeve):
 - 1. Horizontal, Aboveground: No sleeve required unless needed as part of the seal system (i.e. for fire rating) or specifically noted to be provided (i.e. for acoustic, thermal, seal retention, or other purposes). Provide clearances around pipe same as sleeve would provide (see specified sleeve size).
 - 2. Vertical, Slab on Grade: Structural type; except at piping serving individual fixtures or individual heating units in finished areas, the flexible type may be used. Where not installed to be concealed (as in a plumbing chase) install height of flexible type so it is concealed by the floor finish, cabinet base, or an escutcheon.
- B. Installation: Set sleeves plumb or level (or sloped as required for sloped pipes) in proper position, tightly fitted into the work. Set sleeves properly in element for specified projection past adjacent surfaces (see sleeve product specification); cut ends of sleeve as necessary.
- C. Insulation: Insulation shall run continuous through sleeves (unless noted otherwise).

3.02 DUCT SLEEVES

- A. General: Provide sleeves for all ducts passing through walls, floors, partitions, roofs, foundations, footings, grade beams, and similar elements, except that sleeves are not required at core drilled penetrations through solid concrete or where formed openings equivalent to a core drill and provided and where no floor drain serves the room where the penetration occurs. Sleeves shall be the following type aboveground:
 - B. Horizontal, Aboveground: No sleeve required unless needed as part of the seal system (i.e. for fire rating) or specifically noted to be provided (i.e. for acoustic, thermal, seal retention, or other purposes). Provide clearances around pipe same as sleeve would provide (see specified sleeve size).
 - C. Installation: Set sleeves plumb or level (or sloped as required for sloped duct) in proper position, tightly fitted into the work. Set sleeves properly in element for specified projection past adjacent surface (see sleeve product specification); cut ends of sleeve as necessary.
 - D. Insulation: Insulation shall run continuous through sleeves (unless noted otherwise).

3.03 DUCT CLOSURE COLLARS

- A. General: Closure collars shall be provided for all exposed ducts on each exposed penetration where the duct passes through any floors, walls, ceilings, roofs, partitions, and similar elements. Closure collars shall additionally be provided where so noted on the drawings and at all duct penetrations into mechanical rooms, boiler rooms, and rooms housing mechanical equipment (on both sides of the penetration).

- B. Installation: Collar shall be installed tight against surfaces and shall fit snugly around the duct or duct covering. Sharp edges of the collar around insulated duct shall be ground smooth to preclude tearing or puncturing the insulation covering or vapor barrier of insulated ducts. Collars shall be anchored to element penetrated, with fasteners appropriate to material fastening to, on maximum 6 inch centers.

3.04 NON-FIRESTOP SEALS

- A. General: Provide seals around all ducts, conduit, and piping passing through sleeves, walls, floors, roofs, foundations, footings, partitions, and similar elements. Seals shall be watertight where the penetration may be exposed to water or moisture. Provide type of sealant to suit the application.
- B. At Sleeves:
 - 1. Between Sleeve and Penetrated Element: Fill openings around outside of pipe sleeve with same material as surrounding construction, or with material of equivalent fire and smoke rating and properties that allow a tight seal between the sleeve and the surrounding construction. Seal full depth of sleeve for vertical penetrations.
 - 2. Between Pipe and Inside of Sleeve: Provide sealant between outside of pipe or pipe covering (for covered piping systems) and inside of sleeve. Seal depth shall be minimum 1-inch each side. Provide Link Seal type for belowground penetrations, vault wall penetrations, and slab-on-grade penetrations (not required where flexible type sleeves are used).
- C. No Sleeves: Provide "Link-Seal" type for belowground penetrations, vault wall penetrations, and slab-on-grade penetrations. Provide sealant at other areas, type to suit the application. Fully seal between outside of pipe or pipe covering (for covered piping systems) and surrounding construction. Seal depth shall be minimum 1-inch each side.
- D. Plumbing Fixtures: Provide sealant between fixture and abutting building surfaces. Seal so no water or overspray from fixture can enter building construction. See Section 22 40 00.
- E. Preparation: Remove loose materials and foreign matter impairing adhesion of seal. Perform preparation in accordance with recognized standards and sealant manufacturers recommendations. Protect elements surrounding area of work from damage or disfiguration due.
- F. Installation: Install sealants immediately after joint preparation. Install sealants free of air pockets, foreign embedded matter, ridges, and sags. Tool exposed joint surface concave and with a neat finished appearance.

END OF SECTION

SECTION 20 05 48
VIBRATION AND SEISMIC CONTROLS FOR MECHANICAL

PART 1 GENERAL

1.01 RELATED DOCUMENTS

- A. Drawings and general provisions of the Contract, including General and Supplementary Conditions and Division 00 and Division 01 Specification Sections, apply to this Section.
- B. Requirements of Section 20 05 00 apply to this Section.

1.02 WORK INCLUDED

- A. Vibration Isolation.
- B. Seismic Restraints.

1.03 DEFINITIONS

- A. "Equipment" is defined to mean any item with power connections (fans, HV units, AHU units, etc.), and also to include all hoods; but does not include pumps less than 3 hp.
- B. "Equipment Requiring Vibration Isolation" is defined to be any equipment (as defined above) with rotating components (e.g. pumps, fans, etc.).

1.04 SUBMITTALS

- A. General: Submittals shall comply with Section 20 05 00.
- B. Product Data:
 - 1. Submit product data on all items to be used.
 - 2. Submit calculations showing vibration isolation selection for all isolation devices provided under this specification section (i.e. where isolation is not furnished integral with the equipment or by the manufacturer of the equipment).
- C. Shop Drawings: Submit shop drawings for all fabricated support assemblies.

1.05 GENERAL REQUIREMENTS - VIBRATION ISOLATION

- A. General:
 - 1. Select and provide all vibration isolation devices for all equipment requiring vibration isolation so as to provide complete installed mechanical systems free of the transmission of vibration and vibration generated noise to the structure.
 - 2. Vibration isolation is shown on the drawings for various items but is not shown for all items requiring isolation. Provide all isolation as indicated and specified herein.
- B. Supplier: Where not provided by the equipment manufacturer, all vibration isolation devices and support assemblies shall be supplied as a coordinated package by a single vibration isolation manufacturer, under this specification section.
- C. Equipment Manufacturer Items: Isolation devices furnished by equipment manufacturer shall comply with this specification section and be selected by the manufacturer to suit, and provide satisfactory performance, for the applications of this project.

1.06 GENERAL REQUIREMENTS - SEISMIC RESTRAINTS

- A. General: Mechanical equipment, piping, and ductwork seismic restraints are typically not shown on the drawings but are to be provided as specified herein. Contractor is responsible to select and provide all seismic anchoring devices for all mechanical equipment, all piping, and all ductwork.
- B. Seismic Restraint Systems: Seismic restraints system shall be able to withstand seismic forces as required by code but no less than two times the weight of the supported (or anchored) item (including contents) in an upward direction and a force equal to the weight of the item (including contents) in a horizontal direction, without placing excess stress on the item or allowing excess movement of the item (i.e. movement that would cause damage to the item or adjacent items or cause support failure). Forces on equipment shall be applied to the center of gravity of the equipment.

1.07 REFERENCES

- A. IBC: International Building Code.
- B. IMC: International Mechanical Code.
- C. MASON: Mason Industries Seismic Restraint Guidelines for suspended piping, Ductwork, Electrical Systems and Floor Mounted Equipment, 2005 6th Edition.
- D. OSHPD: Office of Statewide Health Planning and Development, State of California, Fixed Anchorage.
- E. SMACNA/SRM: Seismic Restraint Manual Guidelines for Mechanical Systems, 2nd Edition.
- F. UPC: Uniform Plumbing Code.

PART 2 PRODUCTS

2.01 ACCEPTABLE MANUFACTURERS

- A. Products shall comply with Section 20 05 00, Paragraph 2.01, Acceptable Manufacturers.
- B. Products: Mason, Peabody, Kinetics Noise Control, Vibration Eliminators, Amber-Booth.

2.02 NEOPRENE ISOLATORS

- A. Isolation Pads: Oil resistant bridge bearing neoprene pads, minimum 3/4-inch thick, with cross-ribbed or waffle design. Size pads for not more than 50 psi or as recommended by vibration isolator manufacturer. Provide load distribution plates (minimum 3/8" plate steel) to evenly load pads. Mason Type SW (or approved).
- B. Floor Mounted Isolators: Double deflection neoprene mounts, sized for minimum deflection of 0.30-inch. All metal surfaces shall be neoprene covered, base plate shall have mounting holes, and top shall have threaded steel plate or threaded steel insert. Element shall be color coded or labeled with molded symbols to identify capacity. Neoprene shall be bridge bearing type. Mason Series ND (or approved).
- C. Suspension Isolators: Double deflection neoprene type, with isolator encased in open steel bracket, and sized for minimum 0.30-inch deflection. Hanger rod shall be isolated from steel bracket with neoprene grommets. Mason Series HD (or approved).

2.03 SEISMIC RESTRAINTS

- A. General: Comply with code, SMACNA-SRM and MASON.
- B. Materials:

1. Steel shall be per ASTM A36; hangers and other devices shall be per Section 20 05 29 and as shown in SMACNA-SRM or MASON. Sheet metal used for bracing shall be no less than 16 gauge. Material for straps shall be galvanized steel, no less than 18 gauge.
 2. Cabling: Cables shall be minimum 1/8" diameter, 7 x 19 strand, galvanized steel with clear vinyl coating. Provide with galvanized thimble, clamps, and accessories. End termination and clamping/application shall comply with SMACNA-SRM.
- C. Flexible Connectors: As specified in Section 20 05 19 and in Section 23 33 00.

PART 3 EXECUTION

3.01 VIBRATION ISOLATION

- A. General: Provide vibration isolators for all rotating equipment so that no vibration is transmitted to the structure. Isolators shall be the type indicated; except where not shown, type shall be as selected by vibration isolation manufacturer (or equipment manufacturer) to provide adequate isolation.
- B. Installation: Install all vibration isolators in accordance with isolator manufacturer's instructions and isolated equipment manufacturer's recommendations.
- C. Inadequate Isolation: Should vibration isolators prove inadequate to prevent transmission of vibrations to the building structure or limit equipment vibration generated noise, such isolators shall be replaced with isolators having the largest deflection that can be practically installed or otherwise modified/replaced to produce satisfactory isolation. Such replacement shall be at no additional cost to the Owner.

3.02 SEISMIC RESTRAINTS

- A. General: Provide seismic restraints as required by code and as specified. Comply with SMACNA-SRM, and MASON. Anchoring system and restraints shall be able to withstand anticipated seismic forces. Coordinate with equipment manufacturers for proper equipment anchor attachments to withstand anticipated forces. Coordinate with project structural engineer for attachment of seismic restraints to building.
- B. Piping: Longitudinal and transverse bracing shall be required for all piping 2-1/2-inch diameter and larger and on all fuel gas piping 1-inch and larger. Bracing shall be applied as follows:
 1. Transverse bracing shall occur at maximum intervals of 40 feet, except on fuel gas piping on maximum intervals of 20 feet.
 2. Longitudinal bracing shall occur at maximum intervals of 80 feet, except on fuel gas piping on maximum intervals of 40 feet. Transverse bracing for one pipe section may also act as a longitudinal bracing for a pipe section connected perpendicular to it, if the bracing is installed within 2 feet of the elbow or tee of similar size. Piping conveying fluids at 100 degrees F and higher shall have expansion devices provided in-between longitudinal braces to allow for thermal expansion.
 3. Bracing may be omitted when the top of the pipe is suspended 12 inches or less from the supporting structural member and the pipe is suspended by an individual hanger.
- C. Ductwork: Longitudinal and transverse bracing shall be required for all round ducts 28 inches in diameter and larger, for rectangular ducts 6 square feet and larger, and on all duct systems used for life safety and smoke control installed in either the horizontal or vertical position. Bracing shall be applied as follows:
 1. Transverse bracing shall occur at maximum intervals of 30 feet (20 feet for essential facilities), at each duct turn and at the end of a duct run.
 2. Longitudinal bracing shall occur at maximum intervals of 60 feet (40 feet for essential facilities). Transverse bracing for one duct section may also act as longitudinal bracing for

a duct section connected perpendicular to it, if bracing is installed within 4 feet of the intersection and sized and installed on the larger duct.

3. Groups of ducts may be combined in a larger size frame using overall dimensions and maximum weight of ducts. At least two sides of each duct must be connected to the angles of the brace.
4. Walls, including non-bearing fixed partitions which have ducts running through them, may replace a transverse brace.
5. Bracing may be omitted when the top of the duct is suspended 12 inches or less from the supporting structural members and on roof top ductwork.

D. Equipment:

1. Equipment Not Requiring External Vibration Isolation:

- a. General: Shall be rigidly connected to the structure per Section 20 05 29. Restraints (where required) shall utilize welded steel frames, steel braces, straps, or cables. Provide elastomeric (or neoprene) pads (1/4" thick) between seismic straps and equipment.
- b. Base Mounted Equipment:
 - 1) Provide anchorage per Section 20 05 29 and bracing as needed to maintain equipment anchorage with anticipated seismic forces.
 - 2) All equipment shall have seismic bracing where the height of the equipment is 3 or more times the smallest base dimension and where the equipment anchorage alone is not adequate to maintain equipment anchorage with anticipated seismic forces.
 - 3) All water heaters shall have seismic bracing. Equipment which utilizes (or contains) flammables, combustibles, or hazardous materials shall have seismic bracing where the equipment anchorage alone is not adequate to resist anticipated seismic forces.
- c. Other Equipment: All equipment located 31" or more from the point of attachment to the supporting structure shall have seismic bracing. Equipment which utilizes (or contains) flammables, combustibles, or hazardous materials shall have seismic bracing.

2. Equipment with External Vibration Isolation:

- a. General: Restraints shall not impede operation of vibration isolators, and shall use methods complying with SMACNA-SRM or MASON.
- b. Base Mounted Equipment:
 - 1) All equipment shall have seismic bracing where the height of the equipment is 3 or more times the smallest base dimension and where the equipment vibration isolation components are not adequate to maintain equipment in place with anticipated seismic forces.
 - 2) Provide housed spring isolators, seismic snubbers, padded welded steel angle restraint assembly (with minimum 1/4" clearance between pad and equipment), or slack cable restraints.
- c. Other Equipment:
 - 1) All equipment located 31" or more from the supporting structure shall have seismic bracing. Equipment which utilizes (or contains) flammables, combustibles, or hazardous materials shall have seismic bracing.
 - 2) Utilize slacked cable bracing to accommodate equipment movement due to vibration isolator operation but installed so as to prevent more than 2-inch movement in any direction.

E. Bracing Arrangements:

1. Do not use branch ducts or piping to brace main runs or consider as braces for equipment.
2. Do not brace items to dissimilar parts of a building or dissimilar building systems that may respond in a different mode during an earthquake. (Examples: wall and roof, solid concrete wall and lightweight roof, existing building structure and new isolated building structure.)

3.03 TEST AND INSPECTION

- A. Field Inspections: Prior to initial operation, the vibration isolators and seismic devices shall be inspected for conformance to drawings, specifications, and manufacturer's data and instructions. Check all flexible connectors/expansion devices for proper location, guiding, and end anchoring.
- B. Vibration Isolator Inspection: After installation of isolators and seismic restraint devices, remove all shipping blocks and other items that may prevent proper isolator operation. Inspect isolators to verify that the machinery moves freely on its spring isolators within limits of stops or seismic restraint devices. Eliminate or correct interferences.
- C. Tests: Check for vibration and noise transmission through connections, piping, ductwork, foundations, and walls. Adjust, repair, or replace isolators as required to reduce vibration and noise transmissions to specified levels. Re-balance, adjust, or replace machinery with noise or vibration levels in excess of those given in the machinery specifications or machinery manufacturer's data. Check for proper operation of expansion devices and associated items during system warm-up.

END OF SECTION

SECTION 20 05 93
TESTING, ADJUSTING, BALANCING FOR MECHANICAL

PART 1 GENERAL

1.01 RELATED DOCUMENTS

- A. Drawings and general provisions of the Contract, including General and Supplementary Conditions and Division 00 and Division 01 Specification Sections, apply to this Section.
- B. Requirements of Section 20 05 00 apply to this Section.

1.02 WORK INCLUDED

- A. Air Balancing.
- B. Report.

1.03 SUBMITTALS

- A. General: Comply with Section 20 05 00.
- B. Company: Submit name of Company proposed to do the balancing and sample balancing forms. Where the Company has not been pre-qualified, and substitutions are allowed after bidding (see Division 00 and 01), submit information regarding firm qualifications.
- C. Personnel: Submit list of personnel that will be assigned to the project and their qualifications, and list of past projects.
- D. Reports: Preliminary and final balancing reports.

1.04 REFERENCES

- A. AABC-NS: Associated Air Balance Council, National Standards for Field Measurements and Instrumentation.
- B. ASHRAE: Handbook of Fundamentals.
- C. ACGIH-IV: American Conference of Governmental Industrial Hygienists, Industrial Ventilation, A Manual of Recommended Practice.
- D. NEEB-PS: National Environmental Balancing Bureau Procedural Standard for Testing, Adjusting and Balancing Environmental Systems.

1.05 GENERAL REQUIREMENTS

- A. General: Balancing shall be done by a company which specializes in this type of work and is totally independent and separate from the Company which has installed the systems to be balanced.
- B. Balancers Qualifications:
 - 1. General: Work of this Section shall be performed by balancing firms meeting the following and having prior approval from the Engineer:
 - a. Professional Affiliation: Firm shall be an Associated Air Balance Council (AABC) member balancer or National Environmental Balancing Bureau (NEBB) certified balancer.
 - b. Experience: Firm shall have satisfactorily completed the balancing work for at least 5 similar projects in the last 3 years. Similar is defined to mean: within 10% of the same quantity of units and air inlets/outlets, involve same type of systems, be the

- same type of facility (i.e. school, hospital, etc.). The lead field balancer (i.e. the individual who will be on site directing and participating in the balancing efforts) shall have at least 5 years of experience performing balancing work on similar projects.
- c. References: Have five references for similar projects which have been completed in the last three years that will give a good or better performance rating. References shall be engineers, architects, or building owners. As part of the qualification process at least three of these references will be contacted and a rating obtained for the following: timeliness of work (i.e. able to complete work on schedule), cooperative nature of balancer's staff (i.e. ability to work well as a team with other project trades and professionals), overall quality of balancing work, quality of balancing report. Each item will be rated on a scale of 1 to 5 (5 being excellent), with the result averaged, score must be of 4 or better.
2. Pre-Qualified Balancers: As a convenience to the Contractor, the following balancing firms have been pre-qualified. This is not in any way intended to limit competition or prevent other firms from submitting qualifications, but is intended as an aid to Contractors by identifying firms that have been confirmed as meeting the qualification requirements.
 - a. Neudorfer Engineers.
 - b. Hardin and Sons.
 - c. Airtest Company.
 - d. National Indoor Air Care.
 - e. Test Comm.
 - f. Advanced Mechanical Services.
 - g. AccuABC.
 3. Qualification Process: Firms not pre-qualified who desire to perform the balancing work shall submit a substitution request form in accordance with Contract Document requirements (reference Division 00 and 01). In addition to the information required on the substitution request form, submit: Company information, resumes of staff to be assigned, lists of projects, and references (with name of project, staff assigned to project, and contact name and phone number).
- C. Balancing Issues: Notify the Engineer in writing of all problems or discrepancies between actual conditions and what design documents show as work proceeds.
 - D. Engineer's Authority: The Balancer shall be directly responsible to the Engineer and shall perform this work and make system adjustments as directed by the Engineer.
 - E. Lead Balancer: The Balancer shall assign an individual as "lead balancer" to work in the field to directly supervise the balancing work and field technicians. This lead field balancer shall have at least 5 years of experience performing balancing work on similar projects.
 - F. Added Site Visit: The Balancer shall include in his bid one extra site visits and associated time to access system readiness for balancing and resolution of balancing issues. Include added site visit and 8 hours of field balancing time, plus report amendment time to provide added balancing as directed by the Engineer. Such work may occur during the project's construction period or during the warranty period.

PART 2 PRODUCTS

2.01 GENERAL INSTRUMENTATION

- A. General: Balancing equipment shall comply with Associated Air Balance Council recommendations for field measurement instrumentation.

- B. Calibration: All measuring instruments shall be accurately calibrated and maintained in good working order. Calibration dates and certifications shall be available at Engineer's request.
- C. Instruments: Shall be capable of:
 - 1. Air velocity instruments, direct reading in feet per minute with 2% accuracy.
 - 2. Static pressure instruments, direct reading in inches water gauge with 2% accuracy.
 - 3. Tachometers, direct reading in revolutions per minute with 1/2% accuracy; or revolution counter accurate with 2 counts per 1,000.
 - 4. Thermometers, direct reading in degrees Fahrenheit with 1/10 of a degree accuracy.
 - 5. Pressure gauges, direct reading in feet of water or psig with 1/2% accuracy.
 - 6. Water flow instruments, direct reading in feet of water or psig with 1/2% accuracy suitable for readout of balancing valve provided.

PART 3 EXECUTION

3.01 GENERAL

- A. Workmanship: All measurements and adjustments shall be in accordance with AABC-NS, NEEB-PS, and ACGIH-IV and recognized best balancing procedures. Measurements and adjustments of equipment shall be executed in a manner consistent with the manufacturer's recommendations.
- B. Flow Rates:
 - 1. General: All air and water systems shall be completely balanced and adjusted to provide the flow rates indicated (within tolerances indicated in this specification Section), and to produce an even heating and cooling effect and control response.
 - 2. Balancer Determined: Where flow rates have not been indicated the balancer shall determine such flow rates using acceptable practices in accordance with AABC-NS, NEEB-PS, and ASHRAE standards and submit the proposed flow rates to the Engineer for review.
 - 3. Confirmation: Prior to beginning balancing confirm any flow rate changes since design with the submittals and flow rates indicated therein, and with the Engineer to confirm changes made since design. Assume that new flow rates will be issued.
- C. Controls: Consult and coordinate with the Control Contractor for the adjustment and setting of all control devices to allow for the balancing work, and for proper system operation and proper flow rates. Set all controls and valves as required to maintain design flow rates and temperatures as shown on the drawings. Make measurements and provide data to the Control Contractor to allow for proper control of items.
- D. Comfort Adjustments: Make final adjustments for flow rates in order to optimize each space's comfort, including such considerations as temperature, drafts, noise, pressurization, and air changes. Where variances are made from design values, state reasons in report (e.g., "too noisy", "too drafty," etc.). All such variances are subject to approval by the Architect/Engineer.
- E. Deficiency Reports: Submit deficiency reports where the work does not allow balancing to occur or balancing issues develop. Indicate date, system and equipment involved, location, description of deficiency, and related information to allow for diagnosing the problem. Provide suggestions for resolution where possible.

3.02 AIR BALANCING

- A. Pre-check of System: Prior to beginning balancing, perform, as a minimum, the following:

1. Verify that clean filters have been installed, that system is free from debris, and that all inlets/outlets are not obstructed.
 2. Check all fans and equipment to verify that proper start-up and system preparation has been done by the installing contractor.
 3. Check all door/window and similar building opening status to insure building is ready and proper pressurization can be obtained.
 4. Open all dampers to full flow position, check positions and operation of all motorized dampers to allow full system flows.
 5. Review controls and sequences of operation.
- B. Tolerances: All air flow rates (supply, return, and exhaust) shall be adjusted to within plus 10 percent and minus 5 percent of the values shown in the contract documents, except that relative space-to-space pressure relationships shall always be maintained (e.g., restrooms shall be negative relative to other areas, general offices shall be positive, etc.).
- C. Draft and Noise Adjustments: All diffusers, grilles, and registers shall be adjusted to minimize drafts and to eliminate objectionable noise.
- D. Filters: Air balancing shall be done with new, clean air filters installed. Adjust air deliveries so that design quantities will be obtained when filters are half dirty. This condition shall be simulated by covering a portion of the filter area.
- E. Fan Speeds and Drives:
1. Adjust fan speeds and fan drives (adjustable sheaves) as required to produce design flow rates.
 2. Where new sheaves are required, calculate sizing of new sheave and coordinate requirements with the Division 23 Contractor for Division 23 Contractor to furnish the new sheave. Replace existing sheave with new one furnished by the Division 23 Contractor; include bid costs for sheave replacements on all belt driven fans.
 3. Adjust belts for proper tension.
- F. Marking: Upon completion of flow readings and adjustments permanently mark the balanced position of all balancing valves by stamping the indicator plate of the valve.
- G. Duct Traverse: Rectangular duct traverses shall measure the center of equal areas in the air flow stream, with centers not more than 6 inches apart. Round duct traverses shall measure at least 20 locations, with locations being the centers of equal annular area. Reference ACGIH Industrial Ventilation Manual.
- H. One Open Run: Balance each branch run so that there is at least one wide open run; balance branches relative to one another so that at least one branch damper is wide open (except that where unique conditions exist, and the Engineer gives prior approval, one open damper on runs or branches is not required).
- I. Data: Data to be measured/recorded and provided in report for all air handling systems and equipment:
1. Floor plans clearly showing and identifying all diffusers, grilles, OA louvers, ducts and all other items where air flow rates were measured.
 2. Identify manufacturer, model number, size, and type of all air inlets/outlets.
 3. Initial, trial, and final air flow measurements for all diffusers, grilles, OA louvers, ducts, and all other items where air flow rates were measured.
 4. Design air flow rates and percentage final air flow rates are of design values.
 5. Final damper (or other balance device) final position (as a percentage of full open).

6. The connected voltage and corresponding nameplate full load amps, and the initial and final amperages of all fan motors.
7. Initial and final RPMs of all fans.
8. Static pressures on inlet and outlet of all fans.
9. Fan initial and final CFMs.
10. Outdoor air CFMs (record minimum and maximum values).
11. Entering and leaving air temperatures across coils with coils operating at 100% capacity.
12. Static pressure drop across each filter bank and coil.
13. Final position of any speed controls (as percent of full).
14. In addition to data noted elsewhere, provide the following for all equipment which are part of balanced systems:
 - a. Equipment name and number (as used on drawings).
 - b. Service.
 - c. Equipment manufacturer and model number.
 - d. Sheave and belt sizes (where applicable).
 - e. Filters sizes and quantities (where applicable).
 - f. Motor manufacturer and complete nameplate data.
 - g. Design operating conditions.
 - h. Actual operating conditions (flows, pressure drops, rpm, etc.).

3.03 BALANCING REPORT

- A. General: A balancing report shall be submitted as specified herein, documenting all balancing procedures and measurements.
- B. Report Organization: The report shall be divided into logical sections consistent with the building or system layout (i.e. by floors, building wings, air handling units, or other convenient way). Tabulate data separately for each system. Describe balancing method used for each system.
- C. Preliminary Report: Two preliminary review copies of the balancing report shall be submitted to the Architect/Engineer when the balancing work is 90% complete (or as near 90% complete as possible due to uncompleted work of other trades). In addition to containing all the information required of the final report, the preliminary report shall contain a list of all the work required of other trades in order to allow the balancing work to be completed. The Architect/Engineer will review the preliminary report and inform the Contractor of any additional items or revisions required for the final report. Preliminary reports may be omitted where the Architect/Engineer grants approval.
- D. Final Report: Shall be included in the Operation and Maintenance Manual. Submit reports to Contractor for inclusion in Manuals (or, when manuals have been already sent to Engineer, send report to Engineer who will insert report into Manual). Provide number of reports as required to match quantity of O&M Manuals, but in no case less than five.
- E. Format: 8-1/2" x 11" size, neat, clean copies, drawings accordion folded. Report shall be typed, shall have a title page, table of contents, and divider sheets with identification tabs between sections. Information shall be placed in a three hole notebook, with the front cover labeled with the name of the Job, Owner, Architect/Engineer, Balancing Contractor, and Report Date.
- F. Electronic Copy: Provide copy of reports in *.pdf format; submit final report with closeout documents per Divisions 00 and 01. Provide two CD's with each having an electronic copy of

the report in pdf file format. Label CD neatly same report labeling. Provide electronic pdf files to others for inclusion in electronic record documents.

G. General Balancing Information Required:

1. At the beginning of the report, include a summary of problems encountered, deviations from design, remaining problems, recommendations, and comments.
2. List of instruments used in making the measurements and instrument calibration data.
3. Names of personnel performing measurements.
4. Explanation of procedures used in making measurements and balancing each system.
5. List of all correction factors used for all diffusers, grilles, valves, venturi meters, and any other correction factors used.
6. Areas where difficulties were encountered in obtaining design flow rates, or where unstable operating conditions may exist.
7. Note any parts of the system where objectionable drafts or noises may be present and efforts made to eliminate same and why they may still be present.
8. Note where variances from design values occur; explain why.
9. All specified measurements, balancing data, any additional recorded data, and observations.

END OF SECTION

SECTION 20 07 00
MECHANICAL INSULATION

PART 1 GENERAL

1.01 RELATED DOCUMENTS

- A. Drawings and general provisions of the Contract, including General and Supplementary Conditions and Division 00 and Division 01 Specification Sections, apply to this Section.
- B. Requirements of Section 20 05 00 apply to this Section.

1.02 WORK INCLUDED

- A. Duct Insulation.
- B. Pipe Insulation.

1.03 DEFINITIONS

- A. R: Thermal resistance of insulation, in units of hr-sf-deg F/Btu.
- B. Subject to Damage: Items installed exposed less than 8 feet above the walking surface (i.e. floor, platform, roof, grade, etc.) adjacent to the item.
- C. Cold Surfaces: Surfaces that will have operating temperatures below the temperature of the surrounding air by at least 5 deg F or more; includes chilled water piping, cooling condensate piping, air conditioning ductwork, outdoor air ductwork, and similar systems. Surfaces shall be considered a cold surface unless specifically indicated otherwise.

1.04 QUALITY ASSURANCE

- A. All insulation and materials shall have a fire hazard rating not to exceed 25 for flame spread and 50 for smoke development, as tested by ASTM E 84, NFPA 255, and UL 723.

1.05 SUBMITTALS

- A. General: All submittals shall comply with Section 20 05 00.
- B. Product Data: Provide product data on all insulation materials to be used. Indicate thicknesses to be used.

1.06 GENERAL REQUIREMENTS

- A. Code Compliance: Contractor shall insulate all systems with the materials and thicknesses as required by code, but in no case shall the insulation be less than that specified herein. In some cases the specified insulation exceeds code, and shall be provided as specified. Not all systems requiring insulation by code are specified, but shall be provided with insulation where required by code.
- B. Insulation at Hangers: Insulation shall be continuous through hangers on all insulated systems (except ductwork). Inserts at hangers are specified in Section 20 05 29 and are considered as part of the hanger and support system. Inserts are required to be installed at the time of pipe installation and are intended to be installed by the Contractor installing the pipe hangers/supports. See Section 20 05 29.

1.07 REFERENCES

- A. ASTM A 653: Standard Specification for Steel Sheet, Zinc-Coated (Galvanized) or Zinc-Iron Alloy-Coated (Galvannealed) by the Hot Dip Process.
- B. ASTM B 209: Standard Specification for Aluminum and Aluminum-Alloy Sheet and Plate.
- C. ASTM C 411: Standard Test method for Hot-Surface Performance of High Temperature Thermal Insulation.
- D. ASTM C 547: Standard Specification for Mineral Fiber Pipe Insulation.
- E. ASTM C 1136: Standard Specifications for Flexible, Low Permeance Vapor Retarders for Thermal Insulation.
- F. ASTM C 1290: Standard Specification For Flexible Fibrous Glass Blanket Insulation Used to Externally Insulate HVAC Ducts.
- G. ASTM E 84: Standard Test Method for Surface Burning Characteristics of Building Materials.
- H. NCIS: National Commercial & Industrial Insulation Standards, published by Midwest Insulation Contractors Association, 5th Edition.
- I. NFPA 255: Standard Method of Test of Surface Burning Characteristics of Building Materials.
- J. UL 723: Tests for Surface Burning of Building Materials.

PART 2 PRODUCTS

2.01 ACCEPTABLE MANUFACTURERS

- A. Products shall comply with Section 20 05 00, Paragraph Part 2.01, Acceptable Manufacturers.
- B. Insulation: Johns Manville, Armacell, Owens-Corning, Knauf, Rubatex, Aeroflex, Pittsburgh Corning, GLT, Halstead, Gilsulate.
- C. Accessories: Johns Manville, Armacell, Owens-Corning, Knauf, Rubatex, Aeroflex, Pittsburgh Corning, GLT, Halstead, Duro Dyne, Gustin Bacon, Childers, RPR, Tee Cee, Lewco Specialty Products, JPS, Buckaroos.

2.02 DUCT INSULATION

- A. Type: Flexible blanket type, constructed of inorganic glass fibers bonded by a thermosetting resin, complying with ASTM C 1290, Type III. Johns Manville "Microlite" (or approved).
- B. Jacket: FSK type, vapor proof, consisting of an aluminum foil cover reinforced with glass fiber mesh, and laminated to kraft. Water vapor permeance shall not exceed 0.05 perms. Provide with joint sealing tape, minimum 2 inches wide, constructed of jacket material with adhesive to seal all joints.
- C. Thermal Conductivity: Shall not exceed 0.27 Btu-in/hr-sq ft-deg F at 75 deg F.
- D. Operating Limits: 40 degrees F to 250 deg F.
- E. Duct Insulation Thickness:
 - 1. General: Provide insulation densities and thicknesses to achieve the following R values. R values are for the insulation only, in their installed thickness, considering installed duct wrap stretch and in accordance with code.
 - 2. Lining: Where ducts have internal lining, the insulating properties of the lining may be credited toward meeting the required insulation R value; use R-3.65 per inch of installed liner.
 - 3. Supply Air Ductwork:

- a. Inside Building and Within Building's Thermal Envelope: R-3.3 (except where ran exposed in conditioned spaces, no insulation is required).
 - b. Inside Building but Not Within Building's Thermal Envelope: R-7.3.
4. Return Air Ductwork:
- a. Inside Building and Within Building's Thermal Envelope: No insulation required; except where duct contains air that may vary by 10 deg F or more from the space the duct passes through, R-3.3 insulation shall be provided.
 - b. Inside Building but Not Within Building's Thermal Envelope: R-7.3.
5. Outside Air Ductwork: Shall be insulated same as required for the building envelope; except where allowed by code to be insulated less than the building envelope, shall be R-8; insulation is not required where duct run outside the building.
6. Exhaust, Relief, and Special Ductwork:
- a. Inside Building and Within Building's Thermal Envelope:
 - 1) Temperature of Air in Duct within 10 Deg F of Temperature of Air in Spaces Duct Passes Through: No insulation required except ductwork from the system's backdraft damper (or motorized damper) to outside the building shall be insulated same as required for the building envelope.
 - 2) Temperature of Air in Duct more than 10 Deg F Different from temperature of Air in Spaces Duct Passes Through: R-8.3; except ductwork from the system's backdraft damper (or motorized damper) to outside the building shall be insulated same as required for the building envelope (but no less than R-8.3).
 - b. Inside Building but Not Within Building's Thermal Envelope: R-8.3.

2.03 PIPE INSULATION

A. Glass Fiber:

1. Type: Rigid molded type, constructed of glass fibers bonded by a thermosetting resin, complying with ASTM C 547 Type I. Insulation factory molded to match pipe size applied to. Johns Manville "Micro-Lok" (or approved).
2. Jacket: ASJ type, vapor proof, consisting of a white kraft paper cover reinforced with glass fiber and bonded to aluminum foil, with longitudinal self sealing closure system. Provide with butt strips constructed of jacket material with adhesive to seal all joints. Water vapor permeance shall not exceed 0.02 perms.
3. Thermal Conductivity: Shall not exceed 0.24 Btu-in/ hr-sq ft-deg F at 75 deg F.
4. Operating Temperatures: 0 deg F to 850 deg F.

B. Elastomeric Insulation:

1. Type: Flexible cellular elastomeric insulation, factory formed to match pipe sizes applied to, complying with ASTM C 534, Type 1. Armacell "AP/Armaflex SS" (or approved).
2. Thermal Conductivity: Shall not exceed 0.27 Btu-in/ hr-sq ft-deg F at 75 deg F.
3. Water Vapor Transmission: Water vapor permeance shall not exceed 0.08 perms.
4. Operating Temperatures: -200 deg F to 220 deg F; shall be able to withstand 250 deg F temperatures for 96 hours per ASTM C 411 without damage or deformation.
5. Weather Protection: Where installed outdoors provide with metal jacketing to protect from UV and weather exposure.

C. Pipe Fittings: Shall be covered using any one of the following methods of the Contractor's choice:

1. Prefabricated segments of pipe insulation of same materials and thickness as the adjoining pipe insulation, formed to match pipe fitting.

2. Pre-cut fiberglass insulation and pre-molded high impact, gloss white, UV resistant, minimum 20 mil thick, PVC covers suitable for the pipe size and insulation thickness application, PVC cover shall be Johns Manville "Zeston 2000 PVC" (or approved).
 3. Insulating plastic cement brought up the full height of the adjacent covering.
 4. Except, where colored PVC jacketing is applied to piping, fittings shall use PVC covers of the same thickness and color as the PVC jacketing specified for the piping.
- D. Metal Jacket: Aluminum roll jacketing, factory formed to match pipe size and insulation application, with smooth surface, manufactured from 3003 or 5005 aluminum alloy, H-14 temper, conforming to ASTM B 209. Shall be minimum 0.020 inches thick, with an integrally bonded interior 1 mil thick heat bonded polyethylene moisture barrier over the entire surface in contact with the insulation. Fitting covers shall be fabricated of same material as pipe runs, factory formed to match fitting.
- E. Pipe Insulation Types:
1. Aboveground-Inside Building:
 - a. Cooling Coil Condensate: Glass fiber or elastomeric (not required where plastic piping materials used).
 - b. Refrigerant Piping: Elastomeric.
 - c. Other Systems: Glass fiber.
 2. Aboveground-Outside Building: Same as specified above, with metal jacket.
- F. Pipe Insulation Thickness:
1. General: Provide minimum piping insulation thickness indicated, in inches.

INSULATION THICKNESS (INCHES)

Fluid Design Operating Range, deg F	Nominal Pipe Diameter (Inches)				
	<1	1< to 1-1/2	>1-1/2 to <4	4 to <8	≥8
Above 350	4.5	5.0	5.0	5.0	5.0
251 - 350	3.0	4.0	4.5	4.5	4.5
201 - 250	2.5	2.5	2.5	3.0	3.0
141 - 200	1.5	1.5	2.0	2.0	2.0
61 - 140	1.0	1.0	1.5	1.5	1.5
40 - 60	0.5	0.5	1.0	1.0	1.0
Below 40	0.5	1.0	1.0	1.0	1.5

2. Varying Temperatures: Where a system operates over temperature ranges calling for different insulation thicknesses, the thicker insulation requirements shall be met.
3. Refrigerant Piping: Refrigerant piping (RG piping) returning from an evaporator (i.e. cooling coil) to a compressor shall be considered to operate at 40 deg F. Refrigerant piping (RL piping) from a condenser to an evaporator does not require insulation (unless noted otherwise).
4. Cold Water: Cold water piping shall be considered to operate at 56 deg F (unless noted otherwise).

2.04 EQUIPMENT AND SPECIALTIES INSULATION

- A. P-traps and HW/CW Lines on ADA Compliant Sinks and Lavatories: Prefabricated insulation specially designed for p-trap application, with white elastomeric insulation, white high gloss pvc cover, and velcro closure. Provide section for insulating HW stop and CW stop and associated piping of same material. McGuire "Pro-Wrap" (or approved).

- B. Metal Jacket: Minimum 24 gauge galvanized steel complying with ASTM A 653. Provide with longitudinal slip joints and 2-inch laps.

PART 3 EXECUTION

3.01 GENERAL

- A. Pre-Insulation Review: No covering materials shall be applied until systems to be covered have had all tests satisfactorily completed, have had all required inspections, and have been satisfactorily reviewed by the Architect-Engineer. All systems shall be examined by the Contractor to confirm cleanliness and other conditions are appropriate to allow for insulation installation.
- B. Insulation Work Review: No insulated items shall be concealed in the building structure or buried until the insulation work has been satisfactorily reviewed by the Architect/Engineer, and has had all required inspections.
- C. Standards: Materials shall be installed in accordance with manufacturer's written instructions, NCIIS, and shall comply with materials and methods specified herein. The more stringent requirements govern.
- D. Joints/Seams: Joints shall be staggered on multi layer insulation. Locate seams and joints in least visible location.
- E. Insulation Protection: Insulation shall be kept clean and dry and shall be protected from dirt, damage, and moisture. Insulation that becomes dirty, damaged, or wet and cannot be restored to like new condition will be rejected, and shall immediately be removed from the jobsite.
- F. Insulation Interruptions: Insulation shall be neatly finished at all supports, protrusions and interruptions. Provide adhesive and tape seal to maintain vapor barrier integrity.
- G. Equipment and Floor Protection: Cover existing equipment and finished floors to protect such items from insulation fiber and dust. Keep all such existing areas in a "broom clean" condition at the end of each day. Take precautions in these areas to prevent glass fiber and insulation dust from entering ventilation systems or areas adjacent to the work.
- H. Glass Fiber Insulation - General:
 - 1. Finish all insulation ends with joint sealing tape or vapor barrier mastic, no raw edges allowed.
 - 2. Joints: Tightly butt adjacent insulation sections together without any voids. Provide overlap of jacket material over all joints.
- I. Items to Be Insulated: Provide insulation on all ductwork, all piping, all items installed in these duct and piping systems, all air and liquid energy conveying systems and components, all air and liquid energy storage, all equipment, and all energy consuming devices, except where such insulation has been specifically excluded.
- J. Items Excluded from Being Insulated:
 - 1. Sanitary sewer drain lines (except traps at handicap accessible fixtures).
 - 2. Stops and risers at plumbing fixtures (except at handicap accessible fixtures).
 - 3. Factory insulated water heaters (except for base on electric water heaters).
 - 4. Electric motors.
 - 5. Fans.
 - 6. Factory insulated or factory lined HVAC, and AC units.
 - 7. Relief Valves and associated drain piping.
 - 8. Hose bibbs (except where used as drains hot water systems).

9. Fuel piping.
10. Underground cold water piping and associated underground items.

3.02 DUCT INSULATION INSTALLATION

- A. Types and Thickness: Insulate all ducts with insulation type and thickness (to provide the required R value) as specified in "Part 2 - Products".
- B. General: Insulation shall be firmly butted at all joints. All longitudinal seams for flexible insulation shall overlap a minimum of 2 inches. All joints and seams shall be finished with appropriate joint sealing tape. Installation shall provide a continuous sealed vapor barrier over all surfaces; seal all jacket penetrations with vapor barrier mastic or vapor barrier jacket tape.
- C. Attachment: For rectangular ducts over 24 inches wide, duct insulation shall be additionally secured to the bottom of the ductwork with mechanical fasteners on 18 inch centers to reduce sagging. Washers shall be applied without compressing the insulation. Protruding ends or fasteners shall be cut off flush after washers are installed. All seams, joints, penetrations, and damage to the facing shall be sealed with joint sealing tape or vapor retardant mastic or appropriate joint sealing tape.

3.03 PIPE INSULATION INSTALLATION

- A. Types and Thickness: Insulate all piping with insulation type and thickness as specified in "Part 2 - Products". All piping shall be insulated except where specifically excluded.
- B. General: All ends shall be firmly butted together and secured with joint sealing tape. All jacket laps and joint sealing tape shall be secured with outward clinch staples at 4 inch spacing, or by use of a suitable adhesive. Installation shall provide a continuous sealed vapor barrier over all surfaces; seal all jacket penetrations with vapor barrier mastic or vapor barrier jacket tape.
- C. Elastomeric Pipe Insulation: Install with seams and joints sealed with rubberized contact adhesive. Insulation with pre-applied adhesive is not permitted. A brush coating of adhesive shall be applied to both butt ends to be joined and to both split surfaces to be sealed. Adhesive shall be allowed to set until dry to touch but tacky under slight pressure before joining the surfaces. Insulation seals at seams and joints shall not be capable of being pulled apart one hour after application. Provide added tape wrap around insulation to ensure seam and joint closure. Insulation that can be pulled apart one hour (or more) after adhesive installation shall be replaced. Provide metal jacketing over outdoor exposed insulation.
- D. Pipe Hangers: Provide insulation tight up to pre-insulated pipe supports at pipe hangers, seal all joints with joint sealing tape. Pre-insulated pipe supports are specified in Section 20 05 29.
- E. Pipe Sleeves: Run insulation continuous full size through sleeve.

3.04 EQUIPMENT AND SPECIALTIES INSTALLATION

- A. Types and Thickness: All equipment and items installed in insulated duct and piping systems shall be insulated except where specifically noted not to be. Insulation type and thickness shall match the piping system.
- B. ADA Compliant Lavatories and Sinks: Insulate P-trap and HW/CW supplies below lavatory and sink where exposed.

END OF SECTION

SECTION 22 11 00
FACILITY WATER DISTRIBUTION

PART 1 GENERAL

1.01 RELATED DOCUMENTS

- A. Drawings and general provisions of the Contract, including General and Supplementary Conditions and Division 00 and Division 01 Specification Sections, apply to this Section.
- B. Requirements of Section 20 05 00 apply to this Section.

1.02 WORK INCLUDED

- A. Domestic Water Piping.
- B. Valves.
- C. Trap Primers.
- D. Testing and Inspection.
- E. Flushing and Disinfection.

1.03 DEFINITIONS

- A. "Lead-Free" means not containing more than 0.2% lead in solder and flux; and not more than a weighted average of 0.25% lead in wetted surfaces of pipes, pipe and plumbing fittings and fixtures.

1.04 SUBMITTALS

- A. General: Submittals shall comply with Section 20 05 00.
- B. Product Data: Submit manufacturer's product information on all items to be used.
- C. System Tests and Inspections: Submit documentation showing systems have satisfactorily passed all pressure tests and code inspections.
- D. Cleaning and Disinfection: Submit documentation regarding completion of flushing, disinfection, bacteriological tests, and Health Department's acceptance of tests and system.

1.05 GENERAL REQUIREMENTS

- A. ANSI/NSF Compliance: All items in contact with potable water shall be lead free in accordance with ANSI/NSF 61. Plastic piping system components shall comply with ANSI/NSF 14. Only lead-free solder shall be used.
- B. Valves: Shall be dezincification resistant, and shall not contain more than 15% zinc in their chemical composition.

1.06 REFERENCES

- A. ASME B16.15: Cast Bronze Threaded Fittings: Classes 125 and 250.
- B. ASME B16.18: Cast Copper Alloy Solder Joint Pressure Fittings.
- C. ASME B16.22: Wrought Copper and Copper Alloy Solder Joint Pressure Fittings.
- D. ASME B16.24: Cast Copper Alloy Pipe Flanges and Flanged Fittings: Classes 150, 300, 400, 600, 900, 1500, and 2500.

- E. ASTM E84: Standard Test Method for Surface Burning Characteristics of Building Materials.
- F. ASTM B16.18: Seamless Copper Water Tube.
- G. ASTM B32: Solder Metal.
- H. AWS A5.8: Filler Metals for Brazing and Braze Welding.
- I. AWWA B300: Hypochlorites.
- J. AWWA B301: Liquid Chlorine.
- K. AWWA M20: Water Chlorination and Chlorination Practices and Principles, 2nd edition.
- L. ANSI/NSF Standard 14 Plastics Piping System Components and Related Materials.
- M. ANSI/NSF Standard 61 Drinking Water System Components – Health Effects.

PART 2 PRODUCTS

2.01 ACCEPTABLE MANUFACTURERS

- A. Products shall comply with Section 20 05 00, 2.01, Acceptable Manufacturers.
- B. Pipe and Fittings: Any manufacturer with products complying with the Contract Document requirements.
- C. Valves: Conbraco/Apollo, Nibco, Stockham, Walworth, Milwaukee, Kitz, Red-White, Watts, Hammond.
- D. Additional manufacturers are as listed for each individual item.

2.02 PIPE AND FITTINGS

- A. Copper Pipe and Fittings:
 - 1. Pipe: Seamless copper water tube, hard temper (unless noted otherwise), type K or L as indicated, per ASTM B88.
 - 2. Fittings:
 - a. Solder-Joint: Wrought copper and bronze fittings per ASME B 16.22 and cast copper alloy fittings per ASME B16.18, cast bronze threaded fittings per ASME B16.15.
 - b. Flanged: Cast bronze fittings per ASME B16.24.
 - c. Solder Material: 95/5 tin-antimony solder per ASTM B32 or "Silvabrite 100" (95.5 tin/4 copper/0.5 silver) solder; lead free.
 - d. Brazing Material: AWS A5.8, BCuP-5.
- B. Trap Primer Piping: Type L or K "soft" or "hard" (bending temper) copper, with compression fittings or soldered joints or PEX (per ASTM F876 and F877; from trap primer valve to drain).

2.03 VALVES

- A. Ball Valves:
 - 1. 2 Inches and Smaller: 600 psi non-shock cold working pressure, 100 psi at 300 deg F, bronze body, full port, 2 piece construction, anti-blowout stem, reinforced PTFE seats, stainless steel or chrome plated brass or silicon bronze ball, lever handle, solder or threaded connections. Provide with extended lever handle where valve is installed in systems with insulation thickness greater than 0.5 inch. Nibco S-585-66-LF, T-585-66-LF, Nibco S-585-80-LF, T-585-80-LF (or approved).

- B. Balancing Valves: Calibrated balance valve, ball or globe type, bronze body, with brass readout valves with integral EPT insert and check valve to minimize fluid loss during balancing. Valve shall have calibrated nameplate and memory stop. Rated for 200 psig working pressure at 250 degrees F. Valve shall be same size as pipe installed in. Bell & Gossett "Circuit Setter" (or approved).
- C. Drain Valves: Bronze ball valve, minimum 125 psi-swp, anti-blowout stem, stainless steel or chrome plated brass ball, reinforced TFE seat, solder or threaded inlet connection, male 3/4 inch hose thread outlet connection, with brass cap and chain. Nibco S-585-70-HC, T-585-70-HC (or approved).

2.04 ACCESSORIES

- A. Trap Primer Valve: Activated by flow of water in line through the trap primer valve. Brass construction with integral air-gap backflow preventor, stainless steel screen, delivering 0.84 ounces of water at 20 psi with 5 seconds of water flow. Precision Plumbing Products "Prime-Pro" (or approved).

PART 3 EXECUTION

3.01 GENERAL

- A. Workmanship: Installation of all items shall comply with code, best professional practices, manufacturers written installation instructions, and to allow for proper functioning of items being connected to.
- B. Complete System: Provide all piping as indicated and as required to allow supply connections to each fixture and equipment item requiring water supply. Provide offsets as required to accommodate building construction and access requirements per Section 20 05 00. For multistory buildings include costs to offset vertical piping at each floor level since structural member locations will not be the same on each floor.
- C. Coordination: Coordinate installation of items with all trades that are affected by the work to avoid conflicts.
- D. Equipment by Others: Provide piping connections to equipment furnished by others in accordance with Section 20 05 00.
- E. Hot Water Adjustment: Adjust the hot water circulation system for uniform circulation throughout the system; provide balancing of system where hot water circulation system has multiple branches with balancing valves (see balancing specification Section). Install, set, and adjust and all system components for proper operation.

3.02 PIPE AND FITTINGS

- A. Concealed: All piping in finished areas shall be installed concealed unless specifically noted otherwise. Provide escutcheons where piping is allowed to be exposed and pipe passes through building elements (i.e. walls, floors, ceilings, etc.).
- B. Non-Obstructing: Install piping at such heights and in such a manner so as not to obstruct any portion of windows doorways, passageways, or access to any items requiring routine service, maintenance, or inspection. Offset or reroute piping as required to clear any interferences which may occur.
- C. Drawing Review: Consult all drawings for location of pipe spaces, ducts, electrical equipment, ceiling heights, door openings, window openings, and other details and report discrepancies or possible conflicts to Architect/Engineer before installing pipe.
- D. Insulation: Allow sufficient clearances for installation of pipe insulation in thickness specified. If interferences occur, reroute piping to accommodate insulation.

- E. Drainage: Slope all piping to low points to allow the system to be drained. Provide added drain valves where system cannot be drained through fixtures.
- F. Install all piping parallel to the closest wall and in a neat, workmanlike manner. Horizontal exposed straight runs of piping shall not deviate from straight by more than 1/4-inch in ten feet. Vertical piping shall not deviate from plumb by more than 1/8-inch in ten feet.
- G. Do not run any piping above electrical panels (and similar electrical equipment). Provide offsets around such panels as necessary.
- H. Prior to the joining of any section of pipe to a pipe run, the section shall be thoroughly cleaned inside and out, the ends shall be reamed to remove any cutting burrs and piping prepared as recommended by piping and fitting manufacturer.
- I. Threaded Connections: Cut piping carefully, ream, thread and work into place without springing. Use TFE tape or lead and graphite lubricant (on male threads only).
- J. Soldered Connections: Polish contact surfaces of fittings and pipes with emery cloth before fluxing male and female surfaces of joints. Steel wool and sandpaper not permitted for polishing.
- K. Unions: Install unions in pipe connections to valves, coils, and any other equipment where it may be necessary to disconnect the equipment or piping for repairs or maintenance; and as indicated. Where flanged connections occur at equipment additional unions are not required unless indicated otherwise.
- L. Insulating Unions: Install dielectric insulating connectors between all connections of copper piping and steel piping of steel equipment. Where flanged connections occur use insulating type flanges.

3.03 VALVES

- A. General: Provide isolation valves as shown on the drawings. In addition to those shown, provide added valves to allow for the isolation of each group of fixtures, all water heaters, and all individual equipment items (e.g. dishwashers, heat exchangers, etc.).
- B. Installation: Install valves so as to be easily accessible and oriented to permit ease of operation. Valve stem shall be directed toward operator in either the vertical or horizontal direction. Provide access doors for valves not otherwise accessible.
- C. Drain Valves: Provide drain valves at the base of all risers (except not required where risers can be drained through plumbing fixtures or equipment drains). Provide drain valves at piping low points where the piping cannot be drained through fixtures, hose bibs, or equipment drains.

3.04 ACCESSORIES

- A. Trap Primers: Provide trap primers to all vented floor drains, floor receptors, and where required by the code. Install with an isolation valve in the branch line to the trap primer valve.
- B. Access Doors: Provide access doors to all valves, water hammer arrestors, trap primers, backflow preventers, and any other piping accessories which would otherwise be inaccessible. See Section 20 05 19 for access door specifications.

3.05 TESTING AND INSPECTION

- A. All piping shall be tested, inspected, and approved by the local authority having jurisdiction prior to being concealed or covered.
- B. Testing shall be witnessed by the plumbing inspector and the Architect/Engineer (at his option). Notify Architect/Engineer minimum 72 hours prior to date of testing, and mutually agreed upon times arranged.

- C. Piping shall be hydrostatically tested for a period of 2 hours (or as required by local authority having jurisdiction), during which time no drop in pressure or leakage shall occur.
- D. Test pressure shall be not less than 150 percent of the maximum to which the pipe will ordinarily be subjected; but in no case less than 75 psig.
- E. Any leaks or defective piping disclosed by testing and inspection shall be repaired with new materials and the system re-tested.
- F. Provide documentation to the Engineer indicating that the system has been completely pressure tested, and all portions inspected and accepted by the local authority having jurisdiction.

3.06 FLUSHING AND DISINFECTION

- A. System Flushing: After tests are completed, all water piping shall be flushed. In general, sufficient water shall be used to produce a minimum water velocity of 2.5 feet per second through piping being flushed. Flushing shall be continued until discharge water shows no discoloration. System shall be drained at low points. Strainer screens shall be removed, cleaned, and replaced in line. System valves and fixture faucets shall be opened and re-closed to completely flush system. After flushing and cleaning, systems shall be prepared for disinfection service by immediately filling water piping with clean, fresh potable water. Any stoppage, discoloration, or other damage to the finish, furnishings, or parts of the building during this process shall be repaired by the Contractor.
- B. Disinfection:
 - 1. Upon completion of the job and prior to final acceptance, the plumbing system shall be disinfected with Chlorine solution. Review procedures and disinfection with the authority having jurisdiction to insure that all work complies with code requirements. Verify any deviations from specified procedures with the Architect/Engineer prior to proceeding. The chlorinating material shall be either liquid chlorine conforming to AWWA B301 or hypochlorite conforming to AWWA B300 (or as otherwise required by the authority having jurisdiction). Water chlorination procedure shall be in accordance with AWWA M20 (or procedure acceptable to AHJ and to the Architect/Engineer). The chlorinating material shall provide a dosage of not less than 50 parts per million and shall be introduced into the system in an approved manner. The treated water shall be retained in the pipe long enough to destroy all non-spore-forming bacteria.
 - 2. The retention time shall be at least 24 hours and shall produce not less than 10 ppm of chlorine at the extreme end of the system at the end of the retention period. All valves in the system being sterilized shall be opened and closed several times during the contact period. The system shall then be flushed with clean water until the residual chlorine is reduced to less than 1.0 ppm. During the flushing period all valves and faucets shall be opened and closed several times.
- C. Bacteriological Tests: The Contractor shall employ an approved agency to take test samples at several points of the system (i.e. end of each wing, each floor of building, etc.) in properly sterilized containers and arrange with the Health Department (or a test agency acceptable to the Health Department) having jurisdiction to test the samples. Test for coliform and other items as required by the AHJ. Should the samples not test satisfactory, the system shall be re-flushed and disinfected again until satisfactory samples are obtained.
- D. Submittal: Submit documentation stating that flushing and disinfection has been completed, copies of the bacteriological test results, and certification from the Health Department having jurisdiction stating that system has been found acceptable.

END OF SECTION

SECTION 22 13 00
FACILITY SANITARY SEWERAGE

PART 1 GENERAL

1.01 RELATED DOCUMENTS

- A. Drawings and general provisions of the Contract, including General and Supplementary Conditions and Division 00 and Division 01 Specification Sections, apply to this Section.
- B. Requirements of Section 20 05 00 apply to this Section.

1.02 WORK INCLUDED

- A. Soil, Waste and Vent Piping.
- B. Condensate, Overflow, Miscellaneous Drains.
- C. Cleanouts.
- D. Testing and Inspection.
- E. Accessories.

1.03 SUBMITTALS

- A. General: Submittals shall comply with Section 20 05 00.
- B. Product Data: Submit product information on all items to be used.

1.04 REFERENCES

- A. ASME B 16.4: Gray Iron Threaded Fittings.
- B. ASME B 16.12: Cast Iron Threaded Drainage Fittings.
- C. ASME B 16.15: Cast Bronze Threaded Fitting Classes 125 and 250.
- D. ASME B 16.18: Cast Copper Alloy Solder Joint Pressure Fittings.
- E. ASME B 16.22: Wrought Copper and Copper Alloy Solder Joint Pressure Fittings.
- F. ASME B 16.23: Cast Copper Alloy Solder Drainage Fittings.
- G. ASME B 16.29: Wrought Copper and Wrought Copper Alloy Solder Joint Drainage Fittings (DWV).
- H. ASTM A 53: Pipe, Steel, Black and Hot-Dipped, Zinc-Coated, Welded and Seamless.
- I. ASTM A 74: Cast Iron Soil Pipe and Fittings.
- J. ASTM A 888: Hubless Cast Iron Soil Pipe and Fittings for Sanitary and Storm Drain, Waste, and Vent Piping Applications.
- K. ASTM B 32: Solder Metal.
- L. ASTM B 88: Seamless Copper Water Tube.
- M. ASTM B 306: Copper Drainage Tube (DWV).
- N. ASTM C 564: Rubber Gaskets for Cast Iron Soil Pipe and Fittings.
- O. ASTM C 1277: Shielded Couplings Joining Hubless Cast Iron Soil Pipe and Fittings.
- P. ASTM D 1785: Poly(Vinyl Chloride) (PVC) Plastic Pipe, Schedules 40, 80, and 120.

- Q. ASTM D 2321: Standard Practice for Underground Installation of Thermoplastic Pipe for Sewers and Other Gravity-Flow Applications.
- R. ASTM D 2235: Solvent Cement for Acrylonitrile-Butadiene-Styrene (ABS) Plastic Pipe and Fittings.
- S. ASTM D 2466: Poly(Vinyl Chloride) (PVC) Plastic Pipe Fittings, Schedule 40.
- T. ASTM D 2564: Solvent Cements for Poly(Vinyl Chloride) (PVC) Plastic Piping Systems.
- U. ASTM D 2661: Acrylonitrile-Butadiene-Styrene (ABS) Schedule 40 Plastic Drain, Waste, and Vent Pipe and Fittings.
- V. ASTM D 2665: Poly(Vinyl Chloride) (PVC) Plastic Drain, Waste, and Vent Pipe and Fittings.
- W. ASTM D 2751: Acrylonitrile-Butadiene-Styrene (ABS) Sewer Pipe and Fittings.
- X. ASTM D 2843: Density of Smoke from the Burning or Decomposition of Plastics.
- Y. ASTM D 3034: Type PSM Poly(Vinyl Chloride) (PVC) Sewer Pipe and Fittings.
- Z. ASTM D 3212: Joints for Drains and Sewer Plastic Pipes Using Flexible Elastomeric Seals.
- AA. ASTM D 3311: Drain, Waste, and Vent (DWV) Plastic Fittings Patterns.
- BB. ASTM D 4101: Polypropylene Injection and Extrusion Materials.
- CC. ASTM F 477: Elastomeric Seals (Gaskets) for Joining Plastic Pipe.
- DD. CISPI 301: Hubless Iron Soil Pipe and Fittings for Sanitary and Drain, Waste, and Vent Piping Applications.
- EE. CISPI 310: Coupling for Use in Connection with Hubless Cast Iron Soil Pipe and for Sanitary and Storm Drain, Waste, and Vent Piping Applications.

PART 2 PRODUCTS

2.01 ACCEPTABLE MANUFACTURERS

- A. Products shall comply with Section 20 05 00, 2.01, Acceptable Manufacturers.
- B. Pipe and Fittings: Mueller, Cerro, Tyler, Charlotte Pipe and Foundry, AB & I Foundry, Spears Manufacturing, Cresline Northwest.
- C. No Hub Couplings: ANACO, Mission Rubber, Tyler, MG Coupling, Fernco, Clamp-All.
- D. Cleanouts: Josam, Zurn, J.R. Smith, Wade.

2.02 PIPE AND FITTINGS - MATERIALS

- A. No-Hub Cast Iron Pipe and Fittings:
 - 1. Pipe and Fittings: Service weight no-hub cast iron pipe and cast iron fittings, per CISPI 301 and ASTM A 888, for use with mechanical no-hub couplings.
 - 2. Couplings: Per CISPI 310 or ASTM C 1277, with a cast iron or stainless shield, and neoprene gasket per ASTM C 564.
- B. Hub and Spigot Cast Iron Pipe and Fittings: Service weight hub and spigot cast iron pipe and cast iron fittings per ASTM A 74, for use with compression gaskets. Gaskets shall conform to ASTM C 564.
- C. Copper DWV Pipe and Fittings: Copper drainage tube per ASTM B 306. Wrought copper and wrought copper alloy solder joint fittings per ASME B 16.29; or cast copper alloy solder joint fittings per ASME B 16.23.

- D. Copper Pipe and Fittings: Seamless copper water tube, tube L or M, per ASTM B 88. Solder joint wrought copper and bronze fittings per ASME B 16.22 cast copper alloy fittings per ASME B 16.18, and cast bronze threaded fittings per ASME B 16.15 with 95/5 tin-antimony solder per ASTM B 32.
- E. PVC DWV Pipe and Fittings: Polyvinyl chloride drain pipe, solid wall pipe per ASTM D 1785 and ASTM D 2665 with solvent cement joints. Foam (i.e. cellular) core pipe NOT allowed. Polyvinyl chloride DWV fittings conforming to ASTM D 2665 or ASDTM F 1866, with solvent cement joints. Solvent cement shall comply with ASTM D 2564.
- F. PVC Pipe and Fittings: Polyvinyl chloride pipe, schedule 40, per ASTM D 1785. Polyvinyl chloride solvent cement socket type fittings conforming to ASTM D 2466. Solvent cement shall comply with ASTM D 2564.
- G. ABS DWV Pipe and Fittings: Acrylonitrile-butadiene-styrene plastic drain pipe, solid wall pipe per ASTM D 2661 with solvent cement joints. Foam (i.e. cellular) core pipe NOT allowed. Acrylonitrile-butadiene-styrene DWV fittings conforming to ASTM D 2661 or ASTM D 3311. Solvent cement shall comply with ASTM D 2235.

2.03 PIPE AND FITTINGS – APPLICATION

- A. Waste and Vent Piping:
 - 1. Piping 2-1/2 Inches and Smaller Located Above Ground: Galvanized steel DWV, no-hub cast iron, copper DWV, PVC DWV, or ABS DWV.
 - 2. Piping 3 Inches and Larger Located Above Ground and All Piping Located Below Ground: No-hub cast iron, bell and spigot cast iron, copper DWV, PVC DWV, or ABS DWV.
- B. Cooling Condensate Drains: Copper DWV, copper, PVC DWV, or PVC.
- C. Miscellaneous Drains: Copper DWV, copper, PVC DWV, or PVC; except that for corrosive fluids (or corrosive fluid venting) applications use the same materials as specified for the acid waste (or vent) systems, or use PVC.

2.04 CLEANOUTS

- A. General:
 - 1. All cleanouts shall have cast iron bodies with bronze countersunk rectangular slotted plugs, lubricated with a non-hardening teflon base thread lubricant and having a gasket seal.
 - 2. Cleanouts located in waterproof membrane floors shall be provided with an integral cast flange and flashing device.
 - 3. All cleanouts shall be the same size as the pipe which they are intended to serve (but not larger than 4-inch).
 - 4. Pipe fittings for cleanouts which turn through walls or up through floors shall use long sweep ells or a "Y" and 1/8 bend.
 - 5. All cleanouts and access covers shall be provided with vandal proof screws.
- B. Floor Cleanouts: J.R. Smith No. 4100 Series adjustable floor cleanout with round heavy duty nickel bronze top.
- C. Wall Cleanouts: Cast iron ferrule with cast bronze taper threaded plug, with plug tapped 1/4-inch, 20 thread, to accept access cover screw; with stainless steel access cover and vandal proof screw.
- D. Outside Cleanouts: Heavy duty, round, cast iron, double-flanged housing, having scoriated cast iron cover with lifting device, ferrule and bronze closure plug. Housing and lid shall be galvanized and have vandal resistant screws. J.R. Smith No. 4251 or 4256 Series.

2.05 ACCESSORIES

- A. Vent Flashing:
 - 1. General: Style and type to suit roofing system, match vent pipe size, and provide waterproof building penetration. Provide with adequate base size for proper flashing into roof system.
 - 2. EPDM or compression molded rubber; suitable for temperatures from -60 deg F to 270 deg F; resistant to ozone and UV light. Flashing shall have aluminum or galvanized steel base for flashing or attachment to roof (style to suit roof type). Provide stainless steel clamp.
 - 3. 2.5 lb sheet lead, extending as a sleeve all around vent pipe with base extended out minimum 10 inches all around; top counter-flashing overlap 2" and turned down inside vent pipe.

PART 3 EXECUTION

3.01 GENERAL

- A. Installation of all items shall comply with code, best professional practices, manufacturers written installation instructions, and to allow for proper functioning of items being connected to.
- B. Provide all piping as indicated and as required to allow complete and proper waste, drain, and vent connections to each fixture and equipment item requiring connection. Provide offsets as required to accommodate building construction and access requirements per Section 20 05 00. For multistory buildings include costs to offset vertical piping through each floor level since structural member locations will not be the same on each floor.
- C. Coordinate installation of items with all trades that are affected by the work to avoid conflicts.
- D. The work of this section shall include all waste (sanitary sewer), drain, and vent lines inside of the building and 5-feet outside of the building (unless indicated otherwise), to the point of and including connections to outside sanitary sewer lines or sanitary sewer manholes.
- E. Consult manufacturers data and architectural drawings for information on plumbing fixtures before beginning rough-in.
- F. Verify points of connection, invert elevations, and grade requirements before beginning installation or ordering materials.
- G. Stub all piping for all items requiring connections through wall or floor; cap and protect until connection to items is complete.
- H. Vents extending through roof shall terminate at least 10 inches above roofing; and not less than 10 feet from and 3 feet above any building opening. Provide vent flashing at each vent through roof; utilize water-proof method as required to best suit roofing material and roofing system manufacturer.
- I. Trap all fixtures and equipment items as required by governing code; provide proper venting for each trap.
- J. Provide drain piping for all drip pans, unit condensate drains, unit P-traps, etc. Run piping to nearest point of drainage, or as shown on drawings. Where routing is not shown, route to nearest point of proper drainage.
- K. Provide piping connections to equipment furnished by others in accordance with Section 20 05 00.
- L. All excavation, trenching and backfilling shall comply with code and pipe manufacturers recommendations. Below ground plastic pipe installation shall comply with ASTM D 2321 and shall exceed those standards as specified.

3.02 PIPE AND FITTINGS

- A. All piping in finished areas shall be installed concealed unless specifically noted otherwise.
- B. Install piping so as not to obstruct access to any items requiring routine service, maintenance, or inspection. Offset or reroute piping as required to clear any interferences which may occur. Prior to running any piping, confirm with Architect/Engineer (unless is clearly noted to be ran exposed). Install exposed piping so as not to obstruct any portion of windows, doors, doorways, passageways, or items requiring service or access.
- C. Consult all drawings for location of pipe spaces, ducts, electrical equipment, structural elements, ceiling heights, door items requiring access, openings, window openings, and other details and report discrepancies or possible conflicts to Architect/Engineer before installing pipe.
- D. Install all horizontal soil or waste lines with a slope of 1/4-inch per foot unless noted otherwise. Coordinate with AHJ if written approval is required for exceptions to 1/4-inch per foot slope.
- E. Make all changes of direction and junctions with Y fittings and 1/8 bends; use sanitary tee fittings in vertical pipe only.
- F. Provide escutcheons where exposed pipe passes through walls, floors, or ceilings.
- G. Install all piping parallel to the closest wall and in a neat, workmanlike manner. Horizontal straight runs of piping shall not deviate from straight by more than 1/4-inch in ten feet. Vertical piping shall not deviate from plumb by more than 1/8-inch in ten feet.
- H. Do not run any piping above electrical panels (and similar electrical equipment). Provide offsets around such panels as necessary. Such offsets are typically not shown on the plans, but are required per this paragraph.
- I. Prior to the joining of any section of pipe to a pipe run, the section shall be thoroughly cleaned inside and out, the ends shall be reamed to remove any cutting burrs and piping prepared as recommended by piping and fitting manufacturer.
- J. Threaded Connections: Cut piping carefully, ream, thread and work into place without springing. Use TFE tape or lead and graphite lubricant (on male threads only).
- K. Soldered Connections: Polish contact surfaces of fittings and pipes with emery cloth before fluxing male and female surfaces of joints. Steel wool and sandpaper not permitted for polishing.
- L. PVC and ABS Pipe:
 - 1. Solvent Joints: The outside of the PVC pipe shall be chamfered to a minimum of 1/16 inch at approximately 22 degrees. Chemicals used must penetrate the surface of both pipe and fitting which will result in complete fusion at the joint. Use solvent and cement only as recommended by the pipe manufacturer.
 - 2. Plastic to Metal Connections: Work the metal connection first. Use a non-hardening compound on threaded connections. Use only light wrench pressure. Connections between metal and plastic are to be threaded utilizing female threaded adapters only, not male adapters.

3.03 INSTALLATION OF CLEANOUTS

- A. Install cleanouts in all soil and waste piping:
 - 1. As shown on drawings;
 - 2. At no more than 100 foot intervals on horizontal runs (whether shown on drawings or not);
 - 3. At the end of all piping runs;
 - 4. At the base of all vertical risers.

5. At all changes of direction for a run of 10 feet or over;
 6. At all locations shown on the drawings and where needed to correct possible stoppage and as required by governing code.
- B. Where cleanouts occur in concealed spaces provided extensions to floors above or to walls to allow access.
 - C. Provide wall access covers or access doors for all wall cleanouts. See Section 20 05 19 for access doors.
 - D. Floor cleanouts shall be installed so as to be flush with the finished floor; where recessed cleanout covers are used the recess shall be filled flush with material to match the surrounding finished floor.
 - E. Install cleanouts so as to assure proper clearances as required by governing code.

3.04 TESTING AND INSPECTION

- A. All piping shall be tested, inspected and approved prior to being concealed or covered.
- B. Testing shall be by water or air, and comply with code.
- C. Testing shall be witnessed by the code official, the Owner's representative (at their option), and the Engineer (at their option). Prior to beginning testing confirm with the Owner and Engineer their level of involvement in the testing process and extent of witnessing; where they will be witnessing the testing notify them at least 72 hours in advance of the test and confirm their availability; coordinate and reschedule as necessary and arrange mutually agreed upon times for the tests and witnessing to occur.
- D. Water Testing:
 1. Fill system with water so that there is no less than 10 feet of head above the highest system section being tested.
 2. System shall hold pressure for a period of at least 15 minutes with no leakage before the inspection starts.
 3. The system shall be inspected and shall hold tight with no leakage at all points.
- E. Air Testing:
 1. Pressurize system with air so that there is no less than 5 psig of air pressure in the system.
 2. System shall hold pressure for a period of at least 15 minutes without the introduction of additional air before the inspection starts.
 3. The system shall be inspected and shall hold tight with no leakage at all points.
- F. All leaks shall be eliminated and the system re-tested before proceeding with work or concealing pipe.
- G. All repairs to piping shall be with new material and no caulking of screwed joints or holes is allowed.

END OF SECTION

SECTION 22 40 00
PLUMBING FIXTURES

PART 1 GENERAL

1.01 RELATED DOCUMENTS

- A. Drawings and general provisions of the Contract, including General and Supplementary Conditions and Division 00 and Division 01 Specification Sections, apply to this Section.
- B. Requirements of Section 20 05 00 apply to this Section.

1.02 WORK INCLUDED

- A. Plumbing Fixtures and Trim.
- B. Installation/Connection of Equipment Specified Elsewhere.
- C. Adjustment and Cleaning.

1.03 DEFINITIONS

- A. "Plumbing Brass" means "P-traps, stops, strainers, tailpieces, flanges, and other brass fittings and accessories NOT including faucets or stops."
- B. "Trim" includes all plumbing brass items, faucets, and any fixture accessories.
- C. "Accessible" refers to the American's with Disabilities Act, and infers that these fixtures will meet Federal and local code requirements.

1.04 REFERENCES

- A. UPC: Uniform Plumbing Code.
- B. NSF/ANSI Standard 61: Drinking Water System Components – Health Effects.

1.05 SUBMITTALS

- A. General: All submittals shall comply with Section 20 05 00.
- B. Product Data: Submit product data for all plumbing fixtures, plumbing trim, and water heaters.

1.06 GENERAL REQUIREMENTS

- A. Fixture Quality: Provide new fixtures and fittings, approved, free from flaws and blemishes with finished surfaces clear, smooth and bright. Visible parts of fixture brass and accessories, and all items located in accessible cabinet spaces, shall be heavily chrome plated. All stops, P-traps and items exposed to view shall be chrome plated (except where specifically noted otherwise).
- B. Code Compliance: All products and connections shall be in compliance with code, local Utilities Department standards, and Health Department requirements.

1.07 QUALITY ASSURANCE

- A. General: Provide quality assurance checks specified in Section 20 05 00 prior to submitting product data. By submitting products for Engineer's review, the Contractor is confirming that such checks have been performed and that the products are suitable for the intended installation and use.
- B. Fixtures:

1. Types: Verify specified fixture types with the Architectural and Plumbing drawings to confirm the requirements are consistent (e.g. fixtures are wall mounted versus floor mounted type, locations of ADA fixtures match, etc.). Where conflicts occur clearly identify the issue on the fixture submittal along with a proposed resolution; or resolve prior to making the submittal by the project RFI process.
 2. Space Verification: Prior to ordering any fixtures or making submittals, Contractor shall check the drawings and verify that all fixtures will fit the space available (i.e. fixtures fit any cabinets fixtures are to be installed in; fixtures have adequate access clearances for proper use; etc.).
- C. Lead-Free Requirement: All items in contact with potable water shall be lead free. Fixtures used to dispense potable water for drinking shall meet the requirements of NSF/ANSI 61.

PART 2 PRODUCTS

2.01 ACCEPTABLE MANUFACTURERS

- A. Products shall comply with Section 20 05 00, Paragraph 2.01, Acceptable Manufacturers.
- B. Water Closets: Kohler, American Standard, Eljer, Mansfield.
- C. Vitreous china (other than water closets) and enameled cast iron fixtures: American Standard; Kohler, Eljer, Mansfield.
- D. Water Closet Seats: Church; Beneke; Olsonite; Kohler; Bemis.
- E. Floor Drains: J.R. Smith; Zurn; Josam; Mifab.
- F. Plumbing Brass: American Standard; Brasscraft; Chicago Faucet; Crane; Eljer; Frost; Kohler; Speakman; Symmons; T & S Brass; McGuire; Elkay.
- G. Faucets: Chicago Faucet.
- H. Stops: Brasscraft, Pro Flo.
- I. Stainless Steel Sinks: Just, Elkay, Franke.
- J. Service Sinks: Fiat, Stern and Williams, Swan, Kohler, Mustee.
- K. Hot Water Temperature Limiting Valve: Symmons, Watts, Chicago Faucet, Acorn, Leonard.

2.02 PLUMBING FIXTURES

- A. General:
 1. Plumbing Fixtures are listed below by reference numbers, corresponding to the reference number adjoining these items on the drawings.
 2. All vitreous china and enameled cast iron fixtures shall be finished white unless specifically noted otherwise.
 3. All stainless steel sinks shall be sound deadened, and shall have faucet ledge (except where noted specifically without ledge).
 4. In interests of Owner's Standardization, fixtures of similar type shall be product of one manufacturer; trim of similar type shall be product of one manufacturer.
- B. Water Closets:

P-1A Water Closet - Floor Mounted - ADA:

Water Closet: Kohler "Archer", No. K-3551, vitreous china, elongated bowl, floor mounted, floor outlet flush tank toilet with 1.28 gallon flush.

Seat: Kohler "Stronghold", No. K-4731-SC, white plastic elongated seat, open-front and

stainless steel self-sustaining check hinge.

ADA: Configure and install for ADA access. Verify with Architectural drawings for mounting heights and off-center stall dimensions. Provide with flush valve so that handle is on wide side of stall.

P-1B Water Closet - Floor Mounted:

Water Closet: Same as P-1A.

Seat: Same as P-1A.

C. Lavatories:

P-3A Lavatory - Countertop:

Lavatory: Kohler "Brookline", No. K-2202-1 19-1/4" x 16-1/4", cast iron, self-rimming oval lavatory with single hole for faucet and integral overflow.

Plumbing Brass: Kohler No. K-7715 lavatory drain with perforated grate and 1-1/4" tailpiece; Kohler No. 9000 1-1/4" cast brass "P" trap with cleanout; stops and risers per "Specialties" in this specification section.

Faucet: Kohler "Hint", No. K-97060-4 deck mounted single lever faucet with single hole mount, 1.2 GPM spout outlet/aerator & 4" spout.

D. Sinks:

P-5A Sink:

Sink: Kohler "Verse", No. K5267-1, dual compartment, single-hole drill, 18 gauge, stainless steel, 24" front to back x 33" left to right x 7-7/8" deep self-rimming sink with rear faucet ledge.

Plumbing Brass: Elkay stainless steel cup strainers with 1-1/2" tailpieces and 1-1/2" cast brass "P" trap with cleanout; stops and risers per "Specialties" in this specifications section.

Faucet: Kohler "Simplice", No. K-596-CP chrome plated single lever faucet with single hole top mount sink faucet, with three function pull-down sprayhead and 1.5 gpm aerator.

E. Service Sinks:

P-6A Service Sink - Floor Mount:

Sink: Florestone No. MSR-2424 molded fiberglass sink basin, 24" x 24" x 10" high, color white, with minimum 30" long heavy duty reinforced 5/8" diameter flexible hose for connection to 3/4" hose thread, spring loaded stainless steel hose bracket, vinyl rim guards.

Plumbing Brass: Combination dome strainer and lint bucket of minimum 16 gauge 302 stainless steel, with stainless steel screws and 3" drain connection.

Faucet: Chicago Faucet No. 897-RCF combination service sink fitting with 3/4" hose thread on spout, No. 369 handles, wall brace, pail hook, No. R-1/2" flanged female adjustable arms, integral stops, ceramic cartridges, polished chrome-plated.

F. Floor Drains:

P-11A Floor Drain:

J.R. Smith No. 2010-A cast iron body floor drain, with nickel bronze adjustable strainer head, round nickel bronze grate, vandal proof screws, reversible flashing collar, and trap primer connection. Size drain outlet to match pipe size shown on drawings.

2.03 SPECIALTIES

- A. General: Unless indicated otherwise, the following fittings and materials (i.e. specialties) shall be used.

- B. Fixture Traps: 17 gage seamless chrome plated cast brass tubing, with 2 inch minimum seal, and cleanout, size as required by Uniform Plumbing Code (unless a larger size is indicated), and configured to suit the application.
- C. Exposed Piping and Fittings: In finished areas and in accessible cabinets, provide piping with chrome plating or sleeved with chromed sleeves or of stainless steel construction/finish; all chrome to have a bright polished finish. No exposed copper allowed (includes accessible cabinet areas).
- D. Stops: Quarter turn ball valve with loose key, size as scheduled.
- E. Risers: Flexible braided steel type; rated for 125 psig.
- F. Escutcheons: See Section 20 05 19.
- G. Refrigerator Wall Box: 20 gauge hot dipped galvanized steel box with 18 gauge face plate, 1/2" inlet x 1/4" outlet compression angle valve. Guy Gray Model BIM875.
- H. Hot Water Temperature Limiting Valve: Thermostatic water temperature mixing valve with integral checks, complying with ASSE 1070 and UPC Chapter 4. Brass body with brass and stainless steel internal components. Leonard "ECO-Mix" 270 / Symmons "Maxline" Model 5-210.
- I. Sealant: See Section 20 05 30. Sealant at fixtures shall be the silicone type, color to match fixture.

PART 3 EXECUTION

3.01 INSTALLATION OF FIXTURES

- A. General: All fixtures shall be completely connected to piping as needed to make a complete and operable installation.
- B. Fixture Locations: Mounting heights and locations of fixtures shall be as shown on the Architectural drawings and in accordance with Contract Document requirements. Locations shall be verified and coordinated with the various trades affected by the installation of these fixtures. When no indicated or shown, obtain mounting location and heights from the Architect/Engineer prior to installation.
- C. Rough-In: Determine rough-in location of fixture utilities to suit fixture location, fixture dimensions, elements of construction (i.e. beams, studs, electrical, ducts, etc.), access requirements, casework dimensions, items which may drain/connect to fixture, use of fixture, and related considerations. The fixture rough-in locations indicated on the plans is schematic, and is not to be used for final rough-in purposes.
- D. Offsets: Provide offsets in piping to fixtures to accommodate building systems. Such offsets shall include off-setting waste piping into cabinet bases (in kick space where possible) to accommodate beams located directly below walls behind fixtures.
- E. Carriers: All off-the-floor (i.e. wall) mounted fixtures shall be installed with supporting carriers and additional anchors, bracing and supports to transmit fixture loads to the floor and building structure without exceeding the maximum specified fixture movement. Prior to concealing carrier and associated supports review adequacy of support system with Architect/Engineer.
- F. Fixture Sealant: Where fixtures abut to walls, floors, and cabinets seal all joints with a uniform fillet bead of sealant. Provide at other locations as recommended by fixture manufacturer.
- G. Protection: Protect fixtures against use and damage until project substantial completion; provide guards and/or boxing to protect.

3.02 INSTALLATION OF SPECIALTIES

- A. Escutcheons: Provide escutcheons at each point where an exposed pipe or other fitting passes through walls, floors, backs of cabinets, or ceilings.
- B. Stops: Provide stops in water connections to all fixtures/equipment, except where a stop valve is integral to the fixture (e.g. flush valves) and in water connections to all items not served by another valve.
- C. Hot Water Temperature Limiting Valve: Install on all lavatories, bathtubs, showers, whirlpools, bidets and as fixtures required by Code (reference UPC Chapter 4); set for 115 deg F maximum delivery temperature. Test and adjust for proper operation and submit written report documenting work performed.

3.03 ADJUSTMENT AND CLEANING

- A. Cleaning: After completion of installation remove all labels and thoroughly clean all fixtures, trim and fittings.
- B. Adjustment: Adjust all flush valves, fixture stops, faucets, valves, and associated plumbing items as necessary for the proper operation of all fixtures and equipment.

END OF SECTION

SECTION 23 09 33
ELECTRIC AND ELECTRONIC CONTROL SYSTEM FOR HVAC

PART 1 GENERAL

1.01 RELATED DOCUMENTS

- A. Drawings and general provisions of the Contract, including General and Supplementary Conditions and Division 00 and Division 01 Specification Sections, apply to this Section.
- B. Requirements of Section 20 05 00 apply to this Section.

1.02 WORK INCLUDED

- A. Control System Design.
- B. Control System for Building Heating, Ventilation, Air Conditioning, Exhaust.
- C. Control Devices, Components, and Wiring.
- D. Testing, Adjustment, and Commissioning.
- E. Owner Training.

1.03 SUBMITTALS

- A. General: Shall comply with Section 20 05 00.
- B. Product Data: Submit product information on all items to be used.
- C. Shop Drawings: Submit a complete set of shop drawings prior to installation containing the following information: interconnect drawings showing all wiring and control connections; control panel details; arrangement of devices in panels; schedule of dampers with sizes and where used; sequence of operation for all equipment; location of all control devices on scaled building plans; and list of actuators with sizes and where used.
- D. Labeling: Submit list of proposed component labeling.
- E. Operation and Maintenance Manuals: See Section 20 02 00. In addition to the information required by that Section and Division 01, provide (for inclusion in the Manual) the following:
 - 1. System description.
 - 2. Complete sequence of operation.
 - 3. Reduced size (11" x 17") copies of record drawings.
 - 4. Submittal data on all products.

1.04 GENERAL REQUIREMENTS

- A. Design and Installation: The entire control system shall be designed and installed by skilled control system designers, electricians and mechanics, all of whom are properly trained and qualified for the work they perform.
- B. Sole Responsibility: One single Contractor shall be responsible to design, furnish and install the complete Section 23 09 33 control system.
- C. Sequence: System shall have sequence of operation as specified in Section 23 09 93.

1.05 WARRANTY

- A. Warranty: After completion of the installation of the control system and acceptance by the Owner, the system shall be warranted as free against defects in manufacturing, workmanship and materials for a period of two years from date of substantial completion. In addition, the system shall be warranted to provide the sequence of operation and basic features specified, with the accuracy and flexibility also specified. The system shall be repaired or replaced, including materials and labor, if in Owner's and Engineer's reasonable opinion, system is other than as warranted.

PART 2 PRODUCTS

2.01 ACCEPTABLE MANUFACTURERS

- A. Products shall comply with Section 20 05 00, Acceptable Manufacturers.
- B. Thermostats and Time Clocks (Non DDC): Honeywell, Paragon.
- C. Actuators: Belimo, Honeywell, Siemens, Johnson Controls.
- D. Dampers: Ruskin, Greenheck.
- E. Carbon Dioxide Sensors: Honeywell, Vaisla.
- F. Carbon Monoxide and Nitrogen Dioxide Sensors: Brasch, Vaisla.
- G. Control Accessories: Idec, Hoffman, McDonnell, Tridelta, Edwards, Mamac, Penn, Belimo, Honeywell, Johnson Controls, Leviton, Arrow-Hart, Alerton, Allen Bradley.

2.02 BASIC SYSTEM

- A. System Type: The system shall be an electronic or electric type.

2.03 THERMOSTAT AND TIMECLOCK

- A. Programmable Thermostat: Shall be 7-day programmable solid state type, specifically designed for commercial use. Unit (and related relay module, and controls) shall allow for 1st stage economizer cooling, 2nd stage unit cooling, 1st stage heating, 2nd stage heating and provide other features as required by the sequence of operation. Thermostat shall have means to bypass time clock, have Auto-Cool-Off-Heat switching, setpoint adjustments, and time/day adjustments. Unit shall also have capability for averaging multiple remote thermostat sensors with integral or separate economizer logic to provide specified sequence.
- B. Thermostat Sensor: Remote temperature sensor for use with programmable thermostat, specifically designed for commercial use. Unit shall have space temperature sensor, unoccupied mode pushbutton override with LED, and temperature setpoint adjustment.
- C. Accessories: Provide duct temperature sensors required for mixed air applications; shall be the averaging type with a sensor element type so as to sense a representative sample of the medium being controlled. Provide sensors as required to work with economizer controls.
- D. General Time Clock: 365 day programmable timeclock, for control of up to four independent loads each with a different schedule, with 50 setpoints of programming. Each output able to be programmed as a maintained or momentary contact closure with duration of 1 to 59 seconds. Features shall include: Time of day scheduling, holiday programming, daylight savings time adjustment, leap year correction, manual override, and battery back-up (for one month operation without power). Unit shall have a NEMA 1 enclosure.

2.04 CONTROL DAMPERS

- A. Type: Dampers shall be parallel blade or opposed blade type, as selected by contractor to best suit application (unless a specific type is indicated).

- B. Leakage: Class 1A leakage rated in accordance with AMCA 511 (or better, as required by Code).
- C. Construction: Construct of galvanized steel, except where installed in ducts of stainless steel or aluminum construction or handling corrosive air, shall be of stainless steel or aluminum construction (to match duct material). All materials in contact with the airstream shall be suitable for the conditions without deterioration. Provide special coatings as necessary to provide corrosion resistance. Frame shall be minimum 16 gauge.
- D. Blades: Single blade type, not exceeding 6 inches in width, 16 gauge, with neoprene, extruded vinyl or butyl rubber edge seals and flexible metal jamb seals; linkage interconnecting all blades and actuator axle.
- E. Bearings: Nylon, molded synthetic or oil impregnated sintered metal bearings (or other materials as conditions require).

2.05 ACTUATORS

- A. Type: Actuators shall be a brushless DC motor type controlled by a microprocessor.
- B. Operation: Shall be compatible with control devices used with to provide specified sequence and system features. Run time shall be constant, independent of torque. Actuator shall have manual positioning mechanism and control direction of rotation switch accessible on its cover. Provide with auxiliary switches as required for sequence of operation. Actuator shall be proportional or two position type, as required for application.
- C. Sizing: Provide actuator with sufficient power and torque to suit items being controlled and allow proper operation against system pressures liable to be encountered. Actuator shall be capable of driving controlled items from full closed to full open in less than 15 seconds.
- D. Spring Return: All actuators shall spring return upon power interruption: The spring return position shall be a "fail safe" position as dictated by freeze, fire, temperature protection, energy saving, or safe operating requirements. Outside air dampers shall spring return closed; return air dampers shall spring return open.
- E. Accessories: Units shall be complete with all linkages, brackets, and hardware required for mounting and to allow for proper control and operation.

2.06 ACCESSORIES

- A. Wiring and Conduit: Shall comply with Division 26 specifications and with code. Wiring that performs code required life safety shutdown of equipment or fire alarm interface shall comply with NFPA standards and local codes for fire alarm system wiring.
- B. Control Cabinet: Wall mounted, NEMA construction type to suit application, minimum 14 gauge sheet metal, hinged front door with latch. Size as required to house controls.
- C. Relays: Shall be rated for the application, with a minimum of two sets of Form C contacts, enclosed in a dust-proof enclosure. Relays shall have Hand-Off-Auto switch, and LED's (or pilot lights) to indicate the energized mode. Relays shall be rated for a minimum life of one million cycles. Operating time shall be 20 milliseconds or less, with release time of 10 milliseconds or less. Relays should be equipped with coil transient suppression devices to limit transients to 150% of rated coil voltage. Contact rating, and configuration selected to suit application.
- D. Thermowells: Bronze or brass with NPT threads, sized to match device used with. All wells to be installed by the trade installing the piping system the well installs in.
- E. Miscellaneous Components/Sensors/Transmitters/Transformers: Shall be manufacturer's standard, designed for application in commercial building HVAC control systems, compatible with other components so as to provide sequence of operation specified.

PART 3 EXECUTION

3.01 INSTALLATION

- A. General: Provide all devices, sensors, relays, switches, dampers, actuators, conduit, tubing, wiring, motor starters and all other devices required to provide a complete integrated control system with the sequence of operation and features as specified. It is the Contractor's responsibility to coordinate with other trades for the installation of control devices in systems installed by others.
- B. Installation: Install all control components in accordance with manufacturer's instructions and recommendations and best professional practices.
- C. Coordination: Coordinate work with other trades to ensure that all trades have the information necessary so that they may properly install any necessary control components, interconnect with control components, and install their work to accommodate controls. Identify all items requiring ceiling or wall access doors (or other special requirements) to trade installing access doors or performing related work.
- D. Space Requirements and Locations: Carefully check space requirements and coordinate with other trades to ensure that items can be installed in the allotted spaces, including above finished suspended ceilings. Adjust locations of panels, equipment, devices, and the like, to accommodate work and prevent interferences. Determine the exact route and location of wiring, conduit and other control devices prior to beginning work.
- E. Mounting: Mount controls adjacent to associated equipment on vibration free elements on free standing fabricated supports; mount and locate for best access.
- F. Control Cabinets: All electrical devices, relays, and components shall be installed in protective covers (i.e. control cabinets), except where installed concealed above ceilings a cover is not required. Controls/devices shall be logically assembled in cabinet, with all devices and cabinet labeled.
- G. Thermostats: Room thermostats shall be mounted 4'-6" above finished floor unless indicated otherwise. Thermostats shall connect to the HVAC unit serving the space the thermostat is located in, unless indicated otherwise. Not all thermostats are shown on the drawings and those shown are preliminary only. Contractor shall indicate all final thermostat locations on submittal drawings. Contractor is responsible to coordinate locations to avoid tackboards, casework, and other interferences.
- H. Power: It shall be the responsibility of this Contractor to provide power for all control devices requiring power. Coordinate with the Division 26 Contractor to arrange for necessary power circuits. All control devices shall obtain power from circuits dedicated to control power.
- I. Wiring, Conduit and Electrical:
 - 1. General: Provide all electrical wiring and devices in accordance with applicable codes and Division 26 requirements.
 - 2. Conduit: All wiring shall be installed in conduit and in accordance with Division 26 specifications, except that low voltage wiring within ceiling plenum spaces, mechanical mezzanines, and attics may be installed without conduit. Wiring in walls shall be in conduit.
 - 3. Wire Labeling: Label or code wiring at each end to show location of the opposite end. Each point of all field terminal strips shall be permanently labeled or coded to show the instrument of item served. Color coded cable with cable diagrams may be used to accomplish cable identification and terminal strip.
 - 4. Service Loop: Provide minimum of 6" extra wiring at all wiring terminations for ease of future maintenance/servicing. Such extra wiring shall be neatly coiled/bundled to allow for uncoiling when the connected equipment is serviced.

5. Workmanship: Install all conduit and wiring parallel to building lines, in neat bundles, supported at not less than 5 foot intervals.
- J. Component Labeling: All control components, except regular room thermostats, shall be equipped with name plates to identify each control component. Components in finished rooms shall be labeled as to generic item controlled for better user understanding; other devices shall be labeled with the same designation which appears on the Control Diagrams. Contractor shall submit list of proposed labeling prior to installing. Reference Section 20 05 00.
- K. Thermostat Setpoints: Thermostat Setpoints (all adjustable) shall be as follows unless indicated otherwise:
- | | |
|--------------------|--------------|
| Occupied Heating | 70 degrees F |
| Unoccupied Heating | 65 degrees F |
| Occupied Cooling | 75 degrees F |
| Unoccupied Cooling | 85 degrees F |
- L. Motor Starters: Shall be by Division 26; except for loads 1/2 hp and less which shall be by this Section.
- M. Device Duct Installation: All control devices installed in ductwork shall be positively anchored and attached to the ductwork by mechanical means (fasteners, straps, unistrut, etc).
- N. Miscellaneous Controls: Provide all necessary control wiring between units furnished under other specification sections to allow for proper operation. Provide each furnace with a return air duct smoke detector.

3.02 INSTALLER COMMISSIONING

- A. General: The commissioning specified in this paragraph is independent and separate of the commissioning work of others.
- B. Commissioning Plan: Develop a checklist for all control system components to be checked, and the procedure for checking. Develop a plan for how the commissioning will occur and how sequences will be checked.
- C. Commissioning Report: Provide a report documenting all commissioning activities. Report shall be formatted and contain sufficient information so that an independent third party can understand the commissioning that occurred, the results, and the results can be duplicated by following the procedures noted.
- D. Commissioning:
1. General: Check all system connections and control components for proper installation. Provide testing of the control system to verify proper system operation and that the specified sequences of operation are provided. Commissioning shall include checking system under all modes of operation, documenting system performance, making corrections as required for proper operation, and re-testing as needed to obtain final proper operation.
 2. Dampers: Verify all dampers operate through their full range of motion and in the proper direction in response to controls signals.
 3. Sensors/Thermostats: Check measurements of temperature sensors, thermostats, pressure sensors and other devices against independent readings to confirm proper operation and sensor locations. Readjust sensor locations as necessary to account for field conditions that may cause inaccurate measurements.
 4. Calibration: Calibrate items as necessary to allow for their proper operation.
 5. Adjustments: Adjust system settings as needed to allow for best system operation, consistent with the specified sequences and for facilities of the type the system serves.

- E. Start-Up: Coordinate all system and equipment start-up with other trades. Start-up systems in accordance with equipment manufacturer's instructions and in conjunction with trades that installed the items being controlled, so that they (or manufacturer's representatives) are present at start-up. Operate and configure the controls for safe equipment start-up and so that equipment operates in a controlled manner. See equipment specification sections for equipment start-up requirements. Test and observe all equipment being controlled during start-up to confirm proper controls operation.

3.03 OWNER INSTRUCTION

- A. Owner Instruction: Provide instruction to Owner on the operation and maintenance of the control system. Provide field demonstrations and show Owner the locations of all control devices; explain and demonstrate how system adjustments are made; explain and demonstrate system sequences of operation.

END OF SECTION

SECTION 23 09 93
SEQUENCE OF OPERATION FOR HVAC CONTROLS

PART 1 GENERAL

1.01 RELATED DOCUMENTS

- A. Drawings and general provisions of the Contract, including General and Supplementary Conditions and Division 00 and Division 01 Specification Sections, apply to this Section.
- B. Requirements of Section 20 05 00 apply to this Section.

1.02 WORK INCLUDED

- A. Sequence of Operation.

1.03 SUBMITTALS

- A. General: Shall comply with Section 20 05 00.
- B. Sequence: Submit complete description of sequence of operation. Sequence submitted shall not be a direct copy of the sequence specified herein, but shall be written to reflect the actual control sequence provided.
- C. Shop Drawings: Provide complete control system shop drawing.

PART 2 PRODUCTS

NOT USED

PART 3 EXECUTION

3.01 GENERAL

- A. General: Provide complete control system with sequences of operation as specified. All mechanical equipment shall be automatically controlled by the Division 23 control system, unless specifically indicated otherwise. Where no sequence of operation is indicated submit a proposed sequence for Engineer review; such sequences shall match the intended equipment use, code, and ASHRAE standards for the type of equipment and application.
- B. Time Control: Control system shall provide time schedule control (i.e. occupied/unoccupied/warm-up modes switching) for all mechanical equipment. Provide independent occupied/unoccupied schedules and optimum start (i.e. warm-up) cycle for each HVAC units (unless noted otherwise), all fans having time schedule, and all heaters. Except that exhaust fans serving adjacent restroom areas may share time schedules.
- C. Warm-up Control: Control system shall provide warm-up switching for all HVAC units and items indicated as having a warm-up cycle.
- D. Adjustability: All temperature setpoints and time control settings shall be adjustable.
- E. Thermostats: Various thermostats are not shown on the drawings but are required per the sequence of operation specified. Coordinate with Engineer for location of all such thermostats prior to installing. Indicate proposed locations on submittals.
- F. Average Thermostats: Where average thermostats are indicated on plans combine and average temperature requirements from each sensor and use average requirements to control equipment.

- G. Miscellaneous Items: See plans for units with motorized dampers in the ducts and miscellaneous other items requiring control.

3.02 HEAT PUMPS

A. General:

1. Controls shall control the units cooling, heating, system dampers (economizer), in proper sequence to provide a supply air temperature that will satisfy space conditions.
2. Heating and cooling shall be properly sequenced so that there is no overlap between the use of heating and cooling.

B. Occupied Mode:

1. Fan shall run continuously.
2. Unit shall cycle in heating or cooling modes as required to satisfy space thermostat.
 - a. Heating: Heat pump shall operate at 1st stage of heating, with electric heater as final stage.
 - b. Cooling: Heat pumps with economizers shall use outside air as the first stage of cooling. Economizer shall be dry bulb or enthalpy type, using Outside Air (OA) temperature sensor, mixed air temperature sensor and supply air temperature control scheme. Economizer shall be enabled only when OA temperature (or enthalpy) is less than the units Return Air (RA) temperature (or enthalpy). The OA/RA dampers shall be modulated as required to satisfy the supply air temperature control scheme. Heat pump shall operate in the cooling mode as the final stage of cooling. Motorized relief dampers (where applicable) shall operate in unison with the OA dampers to progressively open as the OA dampers open; provide with an offset control so that the relief dampers do not begin opening until the OA dampers are at least 15% open.
3. Outside air dampers shall be under CO2 control when unit is in heating, and under economizer and CO2 control when unit is in cooling (whichever is calling for the most open OA damper position shall control the OA damper). CO2 controls shall open OA damper to maintain space CO2 level of 600 ppm. OA damper shall not close below the minimum airflow setting indicated on the plans; coordinate with balancer for minimum setting.

- C. Unoccupied Mode: Fan shall not run continuously. Unit's fan and heating/cooling shall cycle on and off as required to maintain setback temperatures. Outdoor air dampers shall be fully closed.

- D. Warm-up Mode: Unit shall run as in the unoccupied mode (outdoor air dampers fully closed) until the space temperature has warmed up to the occupied mode heating setpoint, then unit shall operate as specified for the occupied mode.

- E. Mode Control: Units' mode of operation shall be determined by unit thermostat time schedule and time schedule override; warm-up mode shall be initiated by thermostat's optimum start controls.

3.03 HEAT RECOVERY VENTILATOR (HRV-1)

- A. General: Multi-zone heat pump controls shall provide time schedule control of the Heat Recovery Ventilator (HRV) in conjunction with the heat pump units. HRV mode shall match the mode for the heat pump system served, except that when any heat pump (served by the HRV) is in the occupied mode, the HRV shall be on in the occupied mode.

B. Occupied Mode:

1. Fans: Supply and exhaust fans are on.

2. Outside Air and Exhaust Air Dampers: 100% open (dampers and actuators provided with units).
- C. Unoccupied Mode: Unit shall be off.
- D. Warm-up Mode: Unit shall be off.

3.04 ELECTRIC HEATERS – WALL HEATER

- A. Wall Heaters: Shall be controlled by their integral thermostat. Heater shall be on once space temperature has fallen below setpoint, and shall be off once temperature has risen 2 deg F or more above setpoint.

3.05 ELECTRIC HEATERS – DUCT TYPE – SA TEMP CONTROL

- A. General: Heater shall be controlled by a duct mounted temperature sensor and outdoor air temperature sensor. Heater capacity shall be varied to meet the supply air set point.
- B. Operation:
 1. Staged Heaters: Heater shall be allowed to operate once the outside air temperature has fallen below set point (initially set at 60°F) and duct air temperature (downstream of heater) has fallen below set point (initially set at 70°F) with staged control between on/off limits.
 2. SCR Heaters: Heater shall be allowed to operate once the outside air temperature has fallen below set point (initially set at 60°F) and duct air temperature (downstream of heater) has fallen below set point (initially set at 70°F) with proportional control between on/off limits.
- C. Interlock: Shall be hard-wire interlocked with the supply fan on the unit which serves the heater, to only allow heater operation when the unit's fan is proven on. Provide differential pressure switch or CT's at unit fan to provide interlock and proof of operation.

3.06 MISCELLANEOUS CONTROLS

- A. Multi-Zone Heat Pump Unit: Connect thermostat(s) furnished with indoor unit(s) to indoor fan coil, provide control interconnections from indoor fan coil to outdoor condenser unit. Set and adjust for proper operation. See Section 23 81 44 for detailed controls configuration.
- B. Fire Alarm System Shutdown:
 1. Provide necessary conduit, wiring, and accessories to shutdown each unit upon activation of that unit's smoke detectors (Smoke detectors are by Division 23 unless specifically shown on the electrical plans and Division 26 specifications). Connections shall be hardwired, independent of any control system logic, so that failure of control system or loss of control system will in no way prevent the fire alarm shutdown of the system. In addition to shutting down the unit with the alarmed smoke detector, all equipment interlocked or served by that unit shall be off. Other units shall also shut-off as required to avoid building pressure differentials and similar undesirable effects. Upon reset of alarmed device, system shall automatically return to normal, provide time delay start of equipment to prevent excess load starting at the same time.
 2. In addition to the above specified hardwired fire alarm shut-down (which pertains to equipment with smoke detectors), provide the following: Shut-down all air handling equipment when the building fire alarm system goes into alarm. Zone contacts in the fire alarm system are available for this purpose. This added shut-down may be accomplished by use of control logic and is not required to be hardwired but shall be of a fail-safe nature so as to provide the necessary shut-down in case of control failure. Reset shall be same as that specified for hard-wired unit smoke-detector shut-down.

END OF SECTION

SECTION 23 21 28
HVAC CONDENSATE PIPING

PART 1 GENERAL

1.01 RELATED DOCUMENTS

- A. Drawings and general provisions of the Contract, including General and Supplementary Conditions and Division 00 and Division 01 Specification Sections, apply to this Section.
- B. Requirements of Section 20 05 00 apply to this Section.

1.02 WORK INCLUDED

- A. Cooling Coil Condensate Drains.
- B. Overflow, Miscellaneous Drains.
- C. Fabricated P-traps.
- D. Testing and Inspection.

1.03 SUBMITTALS

- A. Submittals shall comply with Section 20 05 00.
- B. Submit product information on all items to be used.

1.04 REFERENCES

- A. ASME B 16.15: Cast Bronze Threaded Fitting Classes 125 and 250.
- B. ASME B 16.18: Cast Copper Alloy Solder Joint Pressure Fittings.
- C. ASME B 16.22: Wrought Copper and Copper Alloy Solder Joint Pressure Fittings.
- D. ASME B 16.23: Cast Copper Alloy Solder Drainage Fittings.
- E. ASME B 16.29: Wrought Copper and Wrought Copper Alloy Solder Joint Drainage Fittings (DWV).
- F. ASTM B 32: Solder Metal.
- G. ASTM B 88: Seamless Copper Water Tube.
- H. ASTM B 306: Copper Drainage Tube (DWV).
- I. ASTM D 1785: Poly(Vinyl Chloride) (PVC) Plastic Pipe, Schedules 40, 80, and 120.
- J. ASTM D 2466: Poly(Vinyl Chloride) (PVC) Plastic Pipe Fittings, Schedule 40.
- K. ASTM D 2564: Solvent Cements for Poly(Vinyl Chloride) (PVC) Plastic Piping Systems.
- L. ASTM D 2665: Poly(Vinyl Chloride) (PVC) Plastic Drain, Waste, and Vent Pipe and Fittings.

PART 2 PRODUCTS

2.01 ACCEPTABLE MANUFACTURERS

- A. Products shall comply with Section 20 05 00, 2.01, Acceptable Manufacturers.
- B. Pipe and Fittings: Mueller, Cerro, Tyler, US Pipe, Charlotte Pipe and Foundry, Pacific States Pipe, Atlantic States, Spears Manufacturing, Cresline Northwest.

- C. Fabricated P-Trap: Rectorseal.

2.02 PIPE AND FITTINGS - MATERIALS

- A. Copper DWV Pipe and Fittings: Copper drainage tube per ASTM B 306. Wrought copper and wrought copper alloy solder joint fittings per ASME B 16.29; or cast copper alloy solder joint fittings per ASME B 16.23.
- B. Copper Pipe and Fittings: Seamless copper water tube, tube L or M, per ASTM B 88. Solder joint wrought copper and bronze fittings per ASME B 16.22 cast copper alloy fittings per ASME B 16.18, and cast bronze threaded fittings per ASME B 16.15 with 95/5 tin-antimony solder per ASTM B 32.
- C. PVC DWV Pipe and Fittings: Polyvinyl chloride drain waste and vent pipe and fittings per ASTM D 2665, with solvent cement joints. Solvent cement shall comply with ASTM D 2564.
- D. PVC Pipe and Fittings: Polyvinyl chloride pipe, schedule 40, per ASTM D 1785. Solvent cement socket type fittings per ASTM D 2466. Solvent cement shall comply with ASTM D 2564.

2.03 PIPE AND FITTINGS - APPLICATION

- A. Cooling Condensate Drains: Copper DWV, copper, PVC DWV, or PVC.
- B. Miscellaneous Drains: Copper DWV, copper, PVC DWV, or PVC. Except that handling acidic or corrosive fluids shall be PVC.

2.04 FABRICATED P-TRAPS

- A. Type: Factory fabricated p-trap with dual cleanouts and clear trap, for cooling coil condensate. Rectorseal "EZ Trap" (or approved).
- B. Construction: Fabricated of schedule 40 PVC, with transparent plastic trap portion. Portion connection to HVAC unit (or coil) drain shall consist of a PVC cross, with top and side cleanouts having caps with integral retaining strap and ring. Outlet portion shall consist of PVC tee fitting, with top portion able to serve as vent.
- C. Size: 3/4-inch unless indicated otherwise. Trap heights shall be sized to suit HVAC unit static pressures, unit configuration (i.e. blow through or draw through), and be consistent with HVAC unit manufacturers installation recommendations.
- D. Cleaning Brush: Provide with bristled flexible shaft cleaning brush, sized for cleaning of p-trap.

PART 3 EXECUTION

3.01 GENERAL

- A. Installation of all items shall comply with code, best professional practices, and manufacturers written installation instructions.
- B. Provide all piping as indicated and as required for all drip pans, unit condensate drains, unit p-traps, and miscellaneous drains and vent connections to all items requiring such drains (i.e. HVAC units, furnaces, boilers, AC units, etc.).
- C. Coordinate installation of items with all trades that are affected by the work to avoid conflicts.
- D. Consult manufacturers data and drawings for information on equipment before beginning drain rough-in.
- E. Verify points of connection, elevations, and grade requirements before beginning installation or ordering materials.

- F. Trap all equipment items as required by code; provide proper venting for each trap as indicated and as required by code.
- G. Run piping to nearest point of drainage, or as shown on drawings. Where routing is not shown, route to nearest point of proper drainage.

3.02 PIPE AND FITTINGS

- A. All piping in finished areas shall be installed concealed unless specifically noted otherwise.
- B. Install piping so as not to obstruct access to any items requiring routine service, maintenance, or inspection. Offset or reroute piping as required to clear any interferences which may occur. Prior to running any exposed piping, confirm with Architect/Engineer (unless is clearly noted to be ran exposed). Install exposed piping so as not to obstruct any portion of windows, doors, doorways, passageways, or items requiring service or access.
- C. Consult all drawings for location or pipe spaces, ducts, electrical equipment, structural elements, ceiling heights, door items requiring access, openings, window openings, and other details and report discrepancies or possible conflicts to Architect/Engineer before installing pipe.
- D. Install all drain lines with a slope of 1/4-inch per foot unless noted otherwise. Coordinate with AHJ if written approval is required for exceptions to 1/4-inch per foot slope.
- E. Provide escutcheons where exposed pipe passes through walls, floors, or ceilings.
- F. Install all piping parallel to equipment and nearby walls and in a neat, workmanlike manner. Horizontal straight runs of piping shall not deviate from straight by more than 1/4-inch in ten feet. Vertical piping shall not deviate from plumb by more than 1/8-inch in ten feet.
- G. Do not run any piping above electrical panels (and similar electrical equipment). Provide offsets around such panels as necessary. Such offsets are typically not shown on the plans, but are required per this paragraph.
- H. Prior to the joining of any section of pipe to a pipe run, the section shall be thoroughly cleaned inside and out, the ends shall be reamed to remove any cutting burrs and piping prepared as recommended by piping and fitting manufacturer.
- I. Threaded Connections: Cut piping carefully, ream, thread and work into place without springing. Use TFE tape or lead and graphite lubricant (on male threads only).
- J. Soldered Connections: Polish contact surfaces of fittings and pipes with emery cloth before fluxing male and female surfaces of joints. Steel wool and sandpaper not permitted for polishing.
- K. PVC Pipe:
 - 1. Solvent Joints: The outside of the PVC pipe shall be chamfered to a minimum of 1/16 inch at approximately 22 degrees. Chemicals used must penetrate the surface of both pipe and fitting which will result in complete fusion at the joint. Use solvent and cement only as recommended by the pipe manufacturer.
 - 2. Plastic to Metal Connections: Work the metal connection first. Use a non-hardening compound on threaded connections. Use only light wrench pressure. Connections between metal and plastic are to be threaded utilizing female threaded adapters only, not male adapters.

3.03 TESTING AND INSPECTION

- A. All piping shall be inspected and approved prior to being concealed or covered.

- B. Provide testing as required by code. Testing shall be by water and shall comply with governing code. Testing shall be witnessed by the plumbing inspector and the Engineer's representative (at his option).
- C. All leaks shall be eliminated and the system re-tested before proceeding with additional work or concealing pipe.
- D. All repairs to piping shall be with new pipe and fitting material's; no caulking of screwed joints or holes is allowed.

END OF SECTION

SECTION 23 31 00
HVAC DUCTS AND CASINGS

PART 1 GENERAL

1.01 RELATED DOCUMENTS

- A. Drawings and general provisions of the Contract, including General and Supplementary Conditions and Division 00 and Division 01 Specification Sections, apply to this Section.
- B. Requirements of Section 20 05 00 apply to this Section.

1.02 WORK INCLUDED

- A. Ductwork Systems.
- B. Flexible Duct.
- C. Acoustical Duct Lining.
- D. Preparation of Duct for Service.

1.03 DEFINITIONS

- A. Duct Sizes: All duct dimensions shown are inside clear dimensions. Where inside duct lining is specified or indicated, duct dimensions are to the inside face of lining.

1.04 QUALITY ASSURANCE

- A. All work and materials shall comply with SMACNA-DCS, NAIMA-DLS, ASHRAE-F, IBC, IMC, NFPA-90A, NFPA-90B, and code. The most restrictive criteria governs.
- B. Leakage Criteria: Duct system shall be constructed and sealed so that leakage does not exceed the following:
 - 1. Supply Duct: 5%.
 - 2. Return Duct: 5%.
 - 3. Exhaust Duct: 5%.
- C. Drawing Review: Prior to beginning any work review all drawings, duct routing, duct connections, equipment configuration, equipment connection locations, and other work details to discover conflicts in anticipated duct arrangement and improper or incomplete connections. Review shall include the following: supply ducts not connected into return (or exhaust) ducts, ducts not crossed and improperly connected in shafts, air outlets/inlets connected to ducts, unit configuration compatible with planned duct connections, louver locations match architectural plans. Submit resolutions of such possible conflicts as submittals with shop drawings of proposed solutions; written description in lieu of shop drawings is acceptable for minor issues.

1.05 SUBMITTALS

- A. General: Comply with Section 20 05 00.
- B. Submit shop drawings for all HVAC ductwork which is to be installed differently than as shown on the drawings.
- C. Submit shop drawings showing proposed resolution of conflicts after review of documents and again after review of actual field conditions.

1.06 DUCT PRESSURE CLASS

- A. Constant Volume Systems: Ductwork shall be constructed to the pressure class corresponding to the static pressure indicated for the fan which serves the duct system or 1-inch pressure class (plus or minus as appropriate), whichever is higher; unless noted otherwise.

1.07 REFERENCES

- A. ADC-FLEX: Air Diffusion Council Flexible Duct Performance and Installation Standards.
- B. ASHRAE-F: ASHRAE Handbook of Fundamentals.
- C. ASTM A 653: Steel Sheet, Zinc Coated (Galvanized) or Zinc-Iron Alloy-Coated (Galvannealed) by the Hot Dip Process.
- D. ASTM A 924: General Requirements for Steel Sheet Metallic-Coated by the Hot-Dip Process.
- E. ASTM E 84: Standard Test Method for Surface Burning Characteristics of Building Materials.
- F. IMC: International Mechanical Code.
- G. NAIMA-DLS: North American Insulation Manufacturers Association Fibrous Duct Liner Standards, 1st Edition.
- H. NFPA 90A: Standard for the Installation of Air Conditioning and Ventilating Systems.
- I. NFPA 90B: Standard for the Installation of Warm Air Heating and Air Conditioning Systems.
- J. SMACNA-DCS: SMACNA HVAC Duct Construction Standards.
- K. UL 181: Underwriter Laboratories Factory-Made Air Ducts and Air Connectors.
- L. UL 181A: Underwriter Laboratories Closure Systems for Use with Rigid Air Ducts.
- M. UL 181BA: Underwriter Laboratories Closure Systems for Use with Flexible Air Ducts and Air Connectors.

PART 2 PRODUCTS

2.01 ACCEPTABLE MANUFACTURERS

- A. Products shall comply with Section 20 05 00, Paragraph 2.01, Acceptable Manufacturers.
- B. Sheet Metal: All domestic manufacturers.
- C. Spin-in Fittings and ATTO: Sheet Metal Connectors Inc., United McGill, Royal Metal Products, Airflow Products Inc.
- D. Gasketing: Preson, Insulfab, Duraco.
- E. Duct Sealant and Tape: Carlisle (Hardcast), Ductmate, Benjamin Foster, Grace Construction Products, United McGill, Polymer Adhesives Sealant Systems, RCD Corporation, Nashua, 3M.
- F. Flexible Duct: Flexible Technology Inc., JP Lamborn Co.; Hart & Cooley, Thermaflex.
- G. Acoustical Duct Lining: Johns-Manville.

2.02 GENERAL MATERIALS

- A. Ducts:
 - 1. Environmental: Construct of galvanized sheet steel, suitable for lock forming without flaking or cracking, conforming to ASTM A653 and A924, having a zinc coating of 0.90 ounces total per square foot for both sides of a sheet, corresponding to coating G90.

- B. Fasteners: Steel construction, electroplated zinc coated, having strength properties adequate for the application, compatible with materials being joined, and in accordance with SMACNA-DCS. Where exposed to corrosive conditions shall be of Type 304 or 316 stainless steel. Type to meet duct pressure class and duct leakage requirements. Where used for the support and anchorage of ducts shall comply with Section 20 05 29, with independent test reports regarding strength.
- C. Spin-in Fittings: Factory fabricated of galvanized steel with die-formed mounting groove and damper with raised damper quadrant where ducts are to be insulated. Collar length for flexible duct attachment shall be at least 2" long.
- D. Air-Tight Take-Off Fittings (ATTO): Factory fabricated of galvanized steel. Flange shall be 1-1/2" wide with 1/8" self-adhesive gasket and pre-drilled fastener holes. Collar length for flexible duct attachment shall be at least 2" long. Where used on round duct mains, shall be saddle type appropriately sized for main duct diameter.
- E. Draw Bands:
 - 1. Metal: Worm gear type clamp, constructed of galvanized steel, stainless steel, or aluminum; minimum 1/2-inch wide band; suitable for 200 pound loading.
 - 2. Non-Metal: Nylon "zip-tie" with self-locking ability, designed for flexible duct usage, minimum 1/4 inch wide, rated for 175 pound load, suitable for temperatures from 0 to 185 deg F; listed per UL181B and labeled "UL181B-C".
- F. Gasketing: Vinyl nitrile, vinyl neoprene, or neoprene nitrile PVC blend; designed for HVAC use with size to suit the application having minimum 1.5-inch width at equipment roof curb applications. Fire hazard rating not to exceed 25 for flame spread and 50 for smoke development per ASTM E 84.
- G. Duct Sealant/Mastic: Water based duct sealant, listed per UL 181B-M and UL 181A-M, suitable for indoor and outdoor use. Fire resistant with a flame spread rating of 5 or less, and a smoke developed rating of 0. Sealant shall be resistant to ultraviolet radiation and ozone. Fiberglass mesh shall be minimum 0.006-inches thick, with minimum 9 x 9 weaves per inch, and 2-inch width; for use with mastic in sealing ductwork. Sealant system shall be suitable for duct system pressure class and materials used with. Carlisle Hardcast "Versa-Grip 181".
- H. Foil Tape: Foil back adhesive tape, listed per UL181A-P and UL181B-FX, with listing labeled on tape outer foil face. Minimum 3-inch width for metal-to-metal applications; minimum 2-inch width for flexible duct applications. 3M No. 3340 or Nashua No. 324A.

2.03 DUCT FABRICATION

- A. Duct Gauge and Reinforcement: Shall be as shown in SMACNA-DCS according to the pressure classification of the system and the duct dimensions; with heavier gauge duct used as required to minimize duct reinforcement to suit space available and other project constraints.
- B. Joints and Seams: Construct in accordance with SMACNA-DCS, code requirements, and these specifications (more stringent governs). Ducts shall be constructed and sealed so that the leakage criteria is not exceeded. Round ducts shall be the spiral seam type; except that branch ducts to individual air inlets/outlets less than 16" diameter may be of other types as allowed by SMACNA-DCS. Coordinate joint spacing with duct reinforcement requirements so that transverse joints having the required stiffness may be incorporated in the reinforcement spacing schedule. Round duct transverse joints shall be made with beaded sleeve joints or flanged connections in accordance with SMACNA-DCS; except that branch ducts to individual air inlets/outlets less than 16" diameter may use other joining methods as are allowed by SMACNA-DCS.
- C. Elbows and Tees: Shall be long-radius type with a center-line radius not less than 1-1/2 times the width or diameter of the duct. Where space does not permit the use of long-radius elbows, short-radius or square elbows with turning vanes may be used. Elbows in round duct systems

with duct pressure class above 2-inches shall be stamped type, welded segmented type, or standing seam segmented type.

- D. Transitions: Increase duct sizes gradually. Transitions for diverging air flow shall be made with each side pitched out not more than 22.5 degrees. Transitions for converging air flow shall be made with each side pitched in not more than 30 degrees. Except that eccentric transitions for round to flat oval may have up to a 45 degree pitch.
- E. Branch Connections: Shall comply with SMACNA-DCS, and as required herein.
 - 1. Rectangular-to-Rectangular: Rectangular take-off with 45 degree angle on "inside" of take-off, minimum 4" length. Reference SMANCA-DCS Figure 4-6. Close corner openings.
 - 2. Rectangular-to-Round:
 - a. Serving Individual Air Inlet/Outlet: Spin-in type connector or air-tight take-off (unless a different fitting type is specifically noted).
 - b. Serving Branch Duct: Rectangular to round transition, with maximum degree pitch as specified for transitions. Rectangular end size shall have free area no less than round end. Rectangular connection to rectangular main shall be made as specified for "Rectangular-to-Rectangular" connections.
 - c. Serving Individual VAV Terminal Unit: Conical type connector, with connector 2" larger on one end and maximum 15 degree pitch on sides.
 - 3. Round-to-Round:
 - a. Serving Individual VAV Terminal Unit: Conical type connector (or conical tee fitting), with connection at the main duct 2" larger than the end serving the VAV terminal unit, and a maximum 15 degree pitch on sides; or "Lo-Loss" tee fitting, equivalent to that manufactured by United McGill.
 - b. Other Connections: Air-tight take-off or constructed in accordance with SMACNA-DCS and recognized professional practices.
 - 4. Other Connections: In accordance with SMACNA-DCS and recognized professional practices.
- F. Lined Ductwork: Contractor Fabricated ductwork with interior duct lining. Duct fabrication and liner installation shall comply with NAIMA-DLS. Lining material shall comply with paragraph titled "Duct Lining" in this specification section.

2.04 FLEXIBLE DUCT

- A. Type: Factory insulated fully lined flexible duct.
- B. Construction: Double-ply neoprene coated polyester fabric hose, reinforced with a steel wire helix. Black color. Fire hazard rating not to exceed 25 for flame spread and 50 for smoke development, as tested by ASTM E84.
- C. Thermal Characteristics: Certified Thermal resistance "R" of 4.2 Hr-SF-deg F/Btu in accordance with ADC-FLEX.
- D. Working Pressure: As required to suit maximum pressure to be encountered on system, but no less than 4-inch wc positive, 0.5-inch wc negative.
- E. Length: Shall not exceed 8 feet where used on duct systems with a pressure class of 2-inches and less; maximum 5 feet length on higher pressure class systems.
- F. Code Compliance: Shall comply with all applicable codes, NFPA 90A, NFPA 90B, and shall be UL listed and labeled as a Class 1 connector per UL 181.

2.05 DUCT LINING

- A. Material: Flexible, inorganic glass fiber material, bonded with thermosetting resin, maximum thermal conductivity of 0.24 Btu-inch/hr-sq. ft.-degree F at 75 degrees F, coated to prevent erosion, conforming to NAIMA-DLS and exceeding that standard as specified herein. Suitable for air temperatures to 250 degrees F, and duct velocities to 6000 feet per minute. Surface shall be coated with an acrylic coating having anti-microbial agents and factory applied edge coating. Johns-Manville "Permacote Linacoustic" (or approved).
- B. Thickness: Lining shall be 1-inch thick except where noted otherwise.
- C. Adhesives and Fasteners: Shall conform to NAIMA-DLS, and as suitable for the duct liner material and ductwork.
- D. Fungi and Bacteria Resistance: Conform to ASTM C 1338 and ASTM G21 for fungi resistance and ASTM G 22 for bacteria resistance.

PART 3 EXECUTION

3.01 DUCTWORK INSTALLATION

- A. General: Install all ductwork with all accessories and connections to provide complete and operable duct systems, in accordance with plans and specifications. See Section 20 05 29 for hangers and supports. Provide quality assurance review of all drawings prior to beginning work (see paragraph titled Quality Assurance, this specification Section and see Section 20 05 00). Provide duct and plenum sizes and locations as shown on the drawings; except as adjusted for field conditions and work of other trades, and with prior approval of the Engineer. See Section 20 05 00 for offsets and transitions to be included in project. Fabricate dryer vent ductwork so that no obstructions to airflow are present in the ductwork.
- B. Coordination: The Contractor shall fully coordinate the work of all trades to avoid interferences and conflicts. Due to the extremely tight spaces in portions of the building, the Contractor shall coordinate duct reinforcement spacing and supports with other trades as necessary to avoid interferences. In addition, the Contractor shall select duct gauge and reinforcement types to avoid interferences. Changes required due to lack of coordination between trades, improper spacing or selection of hangers, or improper duct gauge and reinforcement selection, shall be done at no additional cost to the owner.
- C. Field Measurements: Prior to fabricating any duct materials, the Contractor shall field measure all areas where ducts will be installed to verify room available and all offsets and fittings required. Field verify connection sizes and locations to equipment, louvers, and similar items.
- D. Workmanship: All work shall comply with code, SMACNA-DCS, and other applicable standards. Ducts shall be installed level (unless noted otherwise) and in neat lines with the building construction using best professional practices.
- E. Exposed Ducts: All ducts are to be installed concealed unless indicated otherwise. Ducts that are exposed shall be carefully fabricated, stored, and installed for best appearance. All dents, dings, scratches and other damage shall be repaired for a high quality finished look; all dirt, debris, labels, stickers, lettering, and marks removed; and the duct completely cleaned. Any sealant shall be cleaned to form a straight and even seam adjacent to joints, have no overlap onto duct areas not needing sealant, and have all excess sealant removed (mask off adjacent areas as necessary).
- F. Flexible Duct: May only be used where specifically shown on the plans. Attach flexible duct inner core to sheet metal duct (or connector) with draw band. For insulated type, pull insulation and outer jacket completely over the inner core (at the connection to the sheet metal duct) with outer jacket covering the inner core and tucked back at its end to provide a continuous vapor barrier cover; install draw band to secure the outer jacket and insulation. Use metal type draw bands on duct systems where duct pressure class exceeds 3-inches or where temperature or

other conditions do not allow the non-metal type and where indicated; use type of metal suitable for the conditions without corrosion or other deterioration. Install flexible duct with a centerline turning radius not less than one duct diameter. Where this turning radius cannot be maintained with the flexible duct use sheet metal elbows or (at air inlets/outlets) provide a plenum having a side connection.

- G. Spin-in Fittings/ATTO's: May be used for branch ducts to individual outlets only. Apply a bead of duct sealant to all spin-in fittings where fitting seals against sheet metal duct.
- H. Sealing:
 - 1. General: Use materials listed and approved for the specific application. Foil tape may only be used at duct connections to air inlets/outlets (unless specifically noted otherwise). Clean surfaces to be sealed of moisture and all contaminants. Seal joints in accordance with SMACNA-DCS, sealant manufacturer's instructions, and UL 181.
 - 2. Ductwork: Seal to meet duct leakage criteria of Seal Class C.
 - 3. Flexible Duct: Coat connection of flexible duct to metal duct with duct sealant prior to installing the flexible duct.
 - 4. Air Inlets/Outlets: Seal duct connections (including "cans" or plenums) at air inlets and air outlets with duct sealant or foil tape; except at louvers and exposed ducts only sealant shall be used.
- I. Protective Caps: Provide temporary sheetmetal caps or heavy visqueen covers over all open portions of ductwork to prevent debris, dirt, and dust from entering the ductwork. Such covers shall be installed at the end of each work shift, and shall remain in place until all work activities or events that may cause duct contamination will no longer occur.

3.02 ACOUSTICAL DUCT LINING INSTALLATION

- A. General: Install acoustical duct lining in ducts to extent shown on drawings, covering all interior surfaces. Round ducts shall use factory fabricated double-wall ducts as specified.
- B. Installation: Installation shall comply with NAIMA-DLS and these specifications. The liner shall be cut to assure tightly butted joints.
- C. Liner Attachments: The duct liner shall be applied with a 100% coverage of adhesive. Mechanical Fasteners shall be installed flush with the liner surface, and shall be spaced in accordance NAIMA-DLS.
- D. Horizontal Duct Runs: Tops of ducts over 12" wide and sides of duct over 16" high shall have liner additionally secured with mechanical fasteners.
- E. Vertical Duct Runs: Any side of duct over 12" in size shall have liner additionally secured with mechanical fasteners.
- F. Exposed Edges: All joints, exposed edges and any damaged areas of the liner, shall be heavily coated with fire resistant adhesive/mastic.
- G. Metal Nosing: Install metal nosings on the leading edges of the liner in ducts where the velocity exceeds 4000 feet per minute.

3.03 PREPARATION FOR SERVICE

- A. Cleaning: All ducts shall be wiped or blown clean of all dust and debris prior to the installation of grilles or diffusers. Notify the Engineer to allow for an inspection prior to installing grilles or diffusers.
- B. Contaminated Ducts: Where ducts have been contaminated by dirt or debris during the construction process, the affected duct systems shall be cleaned by an independent firm

specializing in the vacuum cleaning of ductwork. All costs associated with such cleaning shall be the responsibility of the Contractor.

END OF SECTION

SECTION 23 33 00
DUCT ACCESSORIES

PART 1 GENERAL

1.01 RELATED DOCUMENTS

- A. Drawings and general provisions of the Contract, including General and Supplementary Conditions and Division 00 and Division 01 Specification Sections, apply to this Section.
- B. Requirements of Section 20 05 00 apply to this Section.

1.02 WORK INCLUDED

- A. Manual Dampers.
- B. Turning Vanes.
- C. Flexible Connectors.
- D. Duct Access Doors.

1.03 QUALITY ASSURANCE

- A. General: Comply with Section 20 05 00.
- B. Workmanship: Construction and installation of all duct accessories shall comply with applicable SMACNA-DCS, and exceed those standards as noted.

1.04 SUBMITTALS

- A. General: Submittals shall comply with Section 20 05 00.
- B. Product Data: Submit product information on all items to be used.

1.05 REFERENCES

- A. AMCA 500D: Laboratory Methods for Testing Dampers for Rating.
- B. SMACNA-DCS: SMACNA HVAC Duct Construction Standards, 3rd Edition.

PART 2 PRODUCTS

2.01 ACCEPTABLE MANUFACTURERS

- A. Products shall comply with Section 20 05 00, Paragraph 2.01, Acceptable Manufacturers.
- B. Manual Damper Hardware: Duro-Dyne, Young Regulator Co., Ventfabrics, Krueger.
- C. Turning Vanes: Duro-Dyne, Aero-Dyne, Oil Capital Sheet Metal, Airsan.
- D. Flexible Connections: Ventfabrics, Duro-Dyne Elgen.
- E. Duct Access Doors: National Controlled Air, Ventfabrics, United-McGill, Kees, Ruskin, Vent Products.
- F. Building Access Doors: J.R. Smith, Zurn, Acudor, Elmdoor, Kees, J.C. Industries.

2.02 MANUAL DAMPERS

- A. Type: Manually adjustable volume dampers.

- B. Blades: Damper blades shall be fabricated of galvanized steel or stainless steel (unless a specific material is indicated), two gages heavier than duct in which installed, and in accordance with SMACNA-DCS. Maximum blade width 12 inches; fabricate multi-blade dampers with opposed blade pattern for ducts larger than 12" x 48".
- C. Regulators: Damper regulator sets shall have quadrant dial regulator with locking nut, square end bearing one side, and spring round end bearing other side (small sizes) or open end square bearing (larger sizes), axis of blade the long dimension. Multiple blade dampers shall have individual quadrants for each blade or one quadrant with interconnected blades. Regulator sets shall be Duro-Dyne model numbers (or approved equal) as follows:

<u>Max. Blade Dimension</u>	<u>Duro-Dyne Regulator Set</u>	<u>Shaft Size</u>
10" and less	KS-145, 145L	1/4"
11" to 14"	KSR-195, 195L	3/8"
15" to 23"	SRS-388, SB-138, KP105	3/8"
24" and larger	SRS-128, SB-112, KP105	1/2"

- D. Concealed Regulator: For remote damper adjustment with finished ceiling appearance. Shall consist of self-locking regulator of cast alloy construction (with serrated core, spring washer, housing, indicator, lock nut) cast into a cylindrical housing for flush ceiling installation. Housing cover shall be of steel construction, shall telescope into the regulator housing to be flush with the finished ceiling, and be secured to the housing with two screws. Provide with extension rods, linkages, miter gears, and all accessories as needed for proper damper operation. Plain Finish. Ventfabrics No. 666, 667 or Young Regulator Co. No. 301 (or approved equal).

2.03 TURNING VANES

- A. Type: Galvanized steel turning vanes to guide airflow through duct elbows to minimize pressure drop.
- B. Construction: Turning vanes shall comply with SMACNA-DCS. Vanes shall be fabricated of minimum 26 gauge galvanized steel; rails shall be fabricated of minimum 24 gauge galvanized steel. For duct widths less than 12 inches, vanes may be single wall construction; for widths 12" and greater, vanes shall be double wall "airfoil" type.
- C. Spacing: Turning vanes shall be equally spaced in accordance with SMACNA-DCS, parallel to each other, and securely attached to runners.
- D. Unequal Elbows: For elbows where the inlet and outlet dimensions are not the same, modify vane shape or angle to provide optimum turning.

2.04 FLEXIBLE CONNECTORS

- A. Type: Flexible fabric type connectors, to provide vibration isolation at equipment duct connections and to allow for movement in duct systems.
- B. Flexible Fabric:
 - 1. General: Flexible glass fiber fabric with an inorganic elastomeric coating.
 - 2. Width: Minimum 3" wide except at equipment 3 hp or larger with external vibration isolators fabric shall be minimum 6" wide.
 - 3. Indoor Applications: Neoprene type, black color, minimum 22 oz/sq. yard, 500 lbs x 500 lbs tensile strength.
 - 4. Outdoor Applications: Durolon type, white color ozone resistant, 24 oz/sq. yard, 250 lbs x 275 lbs tensile strength.
- C. Metal Collars: Minimum 24 gauge galvanized steel 3" wide metal edge connectors, each side of fabric, connected to fabric by folded over metal seam.

- D. Temperature Rating: Shall be suitable for temperatures from -40 to 200 deg F.
- E. Fire/Smoke Rating: Material shall have a flame spread rating of not over 25, and a smoke developed rating of not higher than 50, and comply with requirements of IMC and NFPA 90A.

2.05 DUCT ACCESS DOORS

- A. Construction: Access doors shall be of double wall construction, made with minimum 24 gage galvanized steel, tight fitting, with sealing gasket, and cam locks (or may be hinged type with latches).
- B. Size:
 - 1. General: Access doors shall be of sufficient size so that items concealed in duct can be serviced and inspected, and shall be adequately sized to allow complete removal of the item being served (where removal cannot be made without disturbing fixed ductwork).
 - 2. Minimum size: Doors shall be minimum 14" x 14". Where duct size will not accommodate this size door, the doors shall be made as large as practicable.
 - 3. Large Sizes: Doors larger than 14" x 14" shall have a minimum of 4 cam locks (or where hinged type is used, have a minimum of two (2) latches).
- C. Insulation: Doors in insulated ducts shall be insulated type, with minimum 1 inch thick fiberglass insulation.

2.06 BUILDING ACCESS DOORS

- A. Type: Hinged lockable steel access doors, for wall or ceiling installation.
- B. Construction: Minimum 16 gauge frame and 14 gauge door, concealed hinge, cam and cylinder lock, anchoring provisions, and 1: wide frame to conceal rough building opening. Provide of 18-8 stainless steel construction with No. 4 finish where used in restrooms, locker rooms, kitchens, and similar "wet" areas. Provide of steel construction with prime coated finish in other areas.
- C. Size: Size shall be 12" x 12" (unless indicated otherwise) but shall be large enough to allow necessary access to item being served and sized to allow removal of the item (where access door is the only means of removal without disturbing fixed construction).
- D. Fire Rating: Door shall maintain fire rating of element installed in; reference drawings for required rating.
- E. Keys: Access doors shall all be keyed alike. Provide two (2) keys for each door.

PART 3 EXECUTION

3.01 MANUAL DAMPERS

- A. General: Dampers shall be fabricated and installed in accordance with SMACNA-DCS requirements for volume dampers.
- B. Locations: Install dampers at locations shown on the drawings in branch ducts to all air inlets/outlets, and at all other locations as required by the Balancer to allow for the balancing of the system. Locate dampers at a point where the damper is most accessible; orient damper regulator for best access.
- C. Non Accessible Dampers: Provide flush-mounted concealed type damper quadrants for ducts concealed in walls or non-removable ceilings and where a remote damper operator has been indicated.
- D. Initial Setting: Set and lock all dampers in the full open position prior to balancing.

- E. Identification: Provide orange surveyor's tape, approximately 18" long tied to each damper regulator (except not required on dampers in ducts exposed to view in finished areas).

3.02 TURNING VANES

- A. General: Install turning vanes in all duct elbows and "T" fittings, and at locations shown on the drawings.
- B. Attachment: Securely attach turning vane runners to ductwork.

3.03 FLEXIBLE CONNECTORS

- A. General: Provide flexible connectors at all duct connections to all equipment, where ducts of dissimilar metals are connected, and where shown on the drawings. Except that flexible connectors are not required on internally spring isolated fans where the fan is located in a separate mechanical room and a flexible connector has not been shown.
- B. Round: For round ducts, the flexible material may be secured by zinc-coated, iron clinch type draw bands directly to adjoining duct; or with normal duct joining methods and using metal collars furnished with flexible connectors.
- C. Slack: Install flexible connections with sufficient slack to permit 1 inch of horizontal or vertical movement of ducts or equipment at flexible connection point without stretching the flexible material. At building expansion joints install sufficient flexible material to allow for 2 inch movement in any direction; provide two flexible connectors separated by a 12 inch section of duct.

3.04 DUCT ACCESS DOORS

- A. General: Provide duct access doors at all automatic control dampers, fire dampers, fire/smoke dampers, smoke dampers, backdraft dampers, all duct coils, thermostats, filters, control devices, and any other components in the duct system that require service or inspection. Coordinate with Section 23 - Controls to confirm quantity and location of control devices.
- B. Size and Location: Access doors shall be of sufficient size and so located so that the concealed items may be serviced and inspected or completely removed and replaced.

3.05 BUILDING ACCESS DOORS

- A. General: Provide access doors in walls, floors, ceilings, etc. as indicated on the drawings and where needed to provide service access or maintenance to duct access doors, backdraft dampers, damper actuators, automatic dampers, coils, control devices, fans, HVAC equipment and similar items.
- B. Coordination: Consult architectural drawings and coordinate location and installation of access doors with trades which are affected by the installation.

END OF SECTION

SECTION 23 37 00
AIR OUTLETS AND INLETS

PART 1 GENERAL

1.01 RELATED DOCUMENTS

- A. Drawings and general provisions of the Contract, including General and Supplementary Conditions and Division 00 and Division 01 Specification Sections, apply to this Section.
- B. Requirements of Section 20 05 00 apply to this Section.

1.02 WORK INCLUDED

- A. GRD Outlets.
- B. GRD Inlets.
- C. Louvers.

1.03 DEFINITIONS

- A. GRD's: Grilles, Registers, and Diffusers.

1.04 REFERENCES

- A. AHRI 885: Procedure for Estimating Occupied Space Sound Levels in the Application of Air Terminals and Air Outlets
- B. AMCA 500: Laboratory Methods of Testing Louvers for Rating.
- C. ASHRAE 70: Method of Testing the Performance of Air Outlets and Air Inlets.
- D. ASHRAE-F: ASHRAE Handbook of Fundamentals.
- E. SMACNA-DCS: HVAC Duct Construction Standards, 3rd Edition.

1.05 SUBMITTALS

- A. General: Comply with Section 20 05 00.
- B. Product Data: Submit product information for all items to be used.

PART 2 PRODUCTS

2.01 ACCEPTABLE MANUFACTURERS

- A. Products shall comply with Section 20 05 00, Paragraph 2.01, Acceptable Manufacturers.
- B. Grilles, Registers and Diffusers: Titus, MetalAire, Krueger, Price, Tuttle & Bailey, Kees, Carnes.
- C. Louvers: Ruskin, Greenheck, Leader Industries, American Warming and Ventilating.

2.02 GENERAL REQUIREMENTS

- A. Type: Air outlets and inlets shall be of the size, type, and with number of throws as shown on the drawings; and shall match the appearance and performance of the manufacturers' models specified and scheduled on the drawings.

- B. Performance: Air outlet and outlet performance shall be based on tests conducted in accordance with ASHRAE 70.
- C. Sound Level: Air outlets and inlets shall not exceed a sound level of NC 30 for the size indicated and airflow rate application. Sound levels shall be determined in accordance with AHRI 885 and ASHRAE-F.
- D. Finish: Grilles, Registers and Diffusers shall have factory applied finish, color as selected by Architect/Engineer, except where indicated to have a brushed aluminum finish (or other finish type). Finish shall be an anodic acrylic paint, baked on, with a pencil hardness HB to H. Pint shall pass a 90 hour ASTM B117 salt spray test, 250 hour ASTM D870 water immersion test, and an ASTM D2794 reverse impact test with at least a 50 inch-pound force applied.
- E. Frame Style: Provide air outlets and inlets with frame style to match ceiling or wall construction installed in. Where supply air outlets or inlets are installed in T-bar ceiling systems, they shall be factory installed in 2' x 2' or 2' x 4' metal panel to match ceiling layout. Where installed against gypsum board surface, brick or similar hard surface, or where exposed, provide with 1-1/4" wide outer border. Where space does not permit installing 2' x 2' metal panel, provide outlets or inlets with 1-1/4" wide outer border. Where air outlets are installed adjacent to surface mounted light fixtures, outlets shall have 4-inch deep drop frames. (See reflected ceiling plan and/or electrical lighting plan for ceiling and lighting types).
- F. Transfer Grilles: Ceiling transfer grilles shall be same as ceiling exhaust grilles (CEG) unless noted otherwise; wall transfer grilles (WTG) shall be same as wall exhaust grilles (WEG) (unless noted otherwise).
- G. Construction: Air outlets and inlets shall be of steel or aluminum construction except that:
 - 1. Where noted to be constructed of a specific material, shall be as noted.
 - 2. In assemblies with a required fire rating and required to have fire dampers shall be of steel construction.
 - 3. In wet areas or subject to condensation (i.e., locker rooms, restrooms, kitchens, exterior soffits, etc.), where not used in fire rated assemblies, shall be of aluminum construction.
 - 4. Air outlets and inlets in the same room, area, or within common view shall be constructed of the same material.

2.03 SUPPLY AIR OUTLETS

- A. Ceiling Diffuser (CD): Aluminum or steel construction, modular core, with multiple curved (or angled) discharge blades, and square neck. Cores shall consist of four separate sections which can be repositioned to allow for one, two, three or four way discharges. Cores shall be easily removed with no tools required. Krueger 1240 Series, Titus MCD, MCD-AA Series (or approved equal).
- B. Ventilation Grille (VG): Non-corrosive construction, with integral adjustable core for varying air volume. Core shall spin in and out with no tools required. Shall have compression spring tabs for round duct installation, no screws required.

2.04 RETURN AND TRANSFER AIR INLETS

- A. Wall Return Grille (WRG): Shall be of aluminum or steel construction, with 35 degree angular horizontal face bars. Unit shall have outer frame border, 1/4" wide, gasketed to prevent air leakage and minimize smudging. Deflecting bars shall be rigid extruded aluminum of semi-air-foil design, on 3/4" centers. Krueger Model No. S580H or S80H. Titus Series 350RL.
- B. Transfer Grille (TG): Aluminum construction, "cube-core" or "egg-crate" type, with 0.025" thick x 1/2" deep strips mechanically joined to form 1/2" x 1/2" x 1/2" cubes. Krueger Series EGC5. Titus Series 50F.

2.05 EXHAUST AIR INLETS

- A. Ceiling Exhaust Register (CER): Same as TG but with opposed blade damper operable from face of register.

2.06 WALL LOUVERS (WL)

- A. Type: High performance, 6" deep, stationary, drainable louvers. Ruskin Model ELF6375DX (or approved).
- B. Frame: 6" deep, constructed of minimum 0.090" 6063t5 extruded aluminum, with integral downspouts in jambs and mullions.
- C. Blades: Shall be constructed of minimum 0.081" 6063t5 extruded aluminum, positioned at 37.5 degree angle on approximately 5-7/8" centers, with drain gutters.
- D. Bird Screen: Shall be constructed of 3/4" mesh, 0.051" aluminum.
- E. Performance: Rated in accordance with AMCA 500. For a 48" x 48" louver, minimum free area of 57%, with pressure drop not exceeding 0.10 inches w.g. at 800 feet per minute. No measurable water penetration at velocity below 1000 feet per minute.
- F. Wind Loading: Louver shall incorporate structural supports required to withstand a wind load of 25 lb. per square foot.
- G. Finish: Kynar Finish; color as selected by Architect.

PART 3 EXECUTION

3.01 INSTALLATION

- A. General: Install air outlets and inlets in locations indicated and so as to conform with building features and coordinated with other work.
- B. Connections: Furnish all necessary screws, clips, duct collars, and transitions required to allow for the installation and connection of ductwork to all air outlets/inlets.
- C. Location Verification: Verify all air inlet/outlet locations with building features and other trades prior to installing any duct systems that will connect to the air outlets/inlets. For locations where air inlet/outlet location is noted to be verified, or location is not clear, develop shop drawings showing the proposed location, or the location that best suits field conditions, and submit for review.
- D. Painting: Paint ductwork and accessories which are visible behind air outlets and inlets flat black. Painting to include ductwork, duct liner, turning vanes, liner attachments, and all visible items (including fastening pins for duct lining).
- E. Weather Exposure: All outlets and inlets exposed to the weather shall be adequately flashed and installed in a manner to assure complete weatherproofness. Sealing and caulking of all outlets and inlets exposed to the weather shall conform to Division 07 and Section 20 05 00.
- F. Provide screened openings (SO) on all duct openings where indicated and where openings do not have grilles or registers.

END OF SECTION

SECTION 23 72 23
HEAT RECOVERY VENTILATOR

PART 1 GENERAL

1.01 RELATED DOCUMENTS

- A. Drawings and general provisions of the Contract, including General and Supplementary Conditions and Division 00 and Division 01 Specification Sections, apply to this Section.
- B. Requirements of Section 20 05 00 apply to this Section.

1.02 WORK INCLUDED

- A. Heat Recovery Ventilators.
- B. Start-up.

1.03 SUBMITTALS

- A. General: Submittals shall comply with Section 20 05 00.
- B. Product Data: Submit product information on unit including fan curves, coil performance, unit construction details, wiring diagram, data showing energy recovery, filter data, and weight.
- C. Shop Drawing: Submit drawings of unit showing all dimensions, locations of unit components, and point of connection of all utilities.
- D. Operation and Maintenance: Submit Operation and Maintenance data and submittal data for inclusion in project O&M Manuals.

1.04 GENERAL REQUIREMENTS

- A. Standardization: All units of the same type shall be the product of the same manufacturer.
- B. Substituted Equipment: The drawings show design configuration based on a particular manufacturer's equipment (i.e. basis of design). Use of another manufacturer's equipment (i.e. substituted equipment) that is configured different from what is shown will require redesign of mechanical ductwork, piping, electrical, structural, unit support systems, and general building construction to accommodate the substituted equipment. Such redesign shall meet the requirements and have the approval of the Architect/Engineer prior to fabrication. Contractor shall submit complete shop drawings showing all alternate unit installation plans and details; shop drawings shall comply with Section 20 05 00. The redesign shall be equal or superior in all respects to the Architect/Engineer's design (as judged by the Architect/Engineer), including such aspects as equipment access, ease of maintenance, duct connection locations, unit electrical requirements, noise considerations, vibration unit performance, and similar concerns. Cost of redesign and all additional costs incurred to accommodate the substitutional equipment shall be borne by the contractor. Contractor is cautioned that certain aspects of the equipment cannot be fully evaluated until items are installed and operational, and all added costs after installation to make units equal to the basis of design shall be by the Contractor.

1.05 REFERENCES

- A. AMCA 230: Laboratory Methods of Testing Air Circulating Fans for Rating and Certification.
- B. AHRI 1060: Standard for Performance Rating of Air-to-Air Exchangers for Heat Recovery Ventilation Equipment.

1.06 WARRANTY

- A. General: See Division 00 and Section 20 05 00 for basic warranty requirements.
- B. Extended Warranty: The HRV core shall be warranted to be free of manufacturing defects and to retain its functional characteristics, under circumstances or normal use, for a period of ten years from the date of purchase. The balance-of-unit shall be warranted to be free of manufacturing defects and to retain its functional characteristics, under circumstances of normal use, for a period of two years from the date of installation.

PART 2 PRODUCTS

2.01 ACCEPTABLE MANUFACTURERS

- A. Products shall comply with Section 20 05 00, Paragraph 2.01, Acceptable Manufacturers.
- B. Energy Recovery Ventilator: RenewAire, Lossnay.

2.02 GENERAL

- A. Guards: Exposed openings into fan housings shall be protected with substantial metal screens or gratings. Electrical components with shock potential shall be physically protected and labeled (label as to hazard and items being accessed).
- B. Fan Balancing: The shaft and fan wheel(s) shall be factory statically and dynamically balanced.
- C. Motors: Shall be UL listed and comply with Section 20 05 00. Motor efficiency shall comply with Code. Motors shall have integral thermal protection with automatic reset.
- D. Outlets and Inlets: Equipment shall be furnished with attachment angles and/or flanges to allow for attaching external ductwork.
- E. Fan Performance: Shall be based on laboratory tests conducted in accordance with AMCA 230. Fan capacity shall not be less than the values scheduled on the drawings and shall be constructed to be able to operate with total pressures 20% higher than that indicated.
- F. Controls: Coordinate with Division 23 Contractor for required interfaces between air handling equipment and building control system.
- G. Gasketing: Where units are furnished in sections, unit manufacturer shall furnish unit with gasketing to allow sealing of adjoining sections.
- H. Sound Tests: Shall be done by fan manufacturer in an AMCA certified sound testing laboratory. Sound tests shall be conducted in accordance with AMCA 300. Provide necessary testing and calculations to develop required sound data. Tested sound power levels shall not exceed specified levels by more than 3 dB in any octave band.
- I. Factory Tests: Every unit shall be factory tested prior to shipping. Tests shall include (as a minimum): Motor dielectric voltage-withstand test, unit dielectric voltage-withstand test, continuity of internal control circuits test, unit amperage test, proper fan operation.

2.03 HEAT RECOVERY VENTILATOR (HRU)

- A. Type: Air-to-air heat recovery unit, with integral exhaust and supply fans, for use with the installed multi-zone heat pump.
- B. Performance: As scheduled on the plans at the conditions shown. Performance shall be certified in accordance with AHRI 1060.
- C. General: Unit shall be factory assembled, wired and factory run tested. The unit shall have factory installed controls for control by the multi-zone heat pump system.

- D. Unit Cabinet: Fabricated of galvanized steel, and covered with polyurethane foam insulation with provisions for external hanging supports to building structure.
- E. Fans: Direct drive centrifugal type, two fans, simultaneously supplying and exhausting air, with permanently lubricated bearings, mounted for quiet operation.
- F. Heat Exchanger: Element shall be constructed of specially treated cellulous fiber membrane separated by corrugated layers to allow total heat (sensible and latent) energy recovery from the exhaust air to the supply air or from the supply air to the exhaust air.
- G. Filters: Shall have protective filters installed at both the supply and exhaust sides with an access cover to allow easy access.
- H. Bypass Damper: Unit shall have an automatic supply side by-pass damper to allow inbound ventilation air (i.e. outside air) to by-pass the heat exchanger when outside weather conditions warrant and cooling is required by the areas served. Unit shall include damper, actuator, linkage, and controls for operation.
- I. Electrical and Controls: Unit shall be for use with power of the voltage/phase scheduled. Unit shall have factory installed controls which allow for unit on/off operation and bypass damper control by the multi-zone heat pump system.

PART 3 EXECUTION

3.01 INSTALLATION

- A. General: Install the units as shown on the drawings, in accordance with manufacturer's instructions, Code, and best construction practices.
- B. Locations: Install at locations indicated, to allow for maintenance access and proper clearances.
- C. Duct Connections: Provide flexible connections in ductwork connections to units.

3.02 START-UP

- A. Initial Checks: Prior to operating units, checks shall be made to insure that adequate voltage, duct connections, electrical connections, control connections, and other items as listed by the manufacturer are properly provided/connected and ready to ensure safe and proper unit operation.
- B. Testing and Adjustment: Operate unit to test for proper operation, including fan rotation, and correct interface to other controls.

END OF SECTION

SECTION 23 81 44
SPLIT SYSTEM HEAT PUMP - DUCTLESS

PART 1 GENERAL

1.01 RELATED DOCUMENTS

- A. Drawings and general provisions of the Contract, including General and Supplementary Conditions and Division 00 and Division 01 Specification Sections, apply to this Section.
- B. Requirements of Section 20 05 00 apply to this Section.

1.02 WORK INCLUDED

- A. Split-System Air Source Heat Pumps.
- B. Refrigeration Piping and Accessories.
- C. System Leak Testing and Charging.
- D. Start-Up.

1.03 SUBMITTALS

- A. General: Shall comply with Section 20 05 00.
- B. Product Data: Provide complete product information on all units; include cooling performance capacities as a function of indoor and outdoor coil db/wb temperatures and indoor coil air flow rates, fan performance (cfm vs. esp), unit efficiencies, dimensions and information on all filters and accessories. Provide information showing dimensions and location of refrigerant, power, and control connections.
- C. Installation: Submit manufacturer's installation instructions.
- D. Submit air conditioning unit inspection and start-up report.

1.04 QUALITY ASSURANCE

- A. Listing: Units shall be listed by an approved testing laboratory for the use and application intended.
- B. Rating and Certification: Cooling performances shall be tested and rated in accordance with AHRI 210/240.
- C. Applications: Units shall be intended for commercial use and shall include all manufacturers recommended accessories for proper operation for the application intended.
- D. Code Compliance: Units shall be rated in accordance with recognized standards and meet code requirements for energy efficiencies. Units shall be constructed and designed to conform to applicable codes and standards.
- E. Standardization: In interests of Owner's standardization, all equipment of the same type shall be the product of the same manufacturer.
- F. Operating Conditions: Unless more extreme temperatures are noted elsewhere, or required by local conditions or the specific application, unit shall comply with the following:
 - 1. Unit and all components exposed to ambient conditions shall be able to withstand ambient temperatures from -10 deg F to 125 deg F, plus direct exposure to sun and weather elements without adverse affects.

2. Unit shall be able to operate and produce cooled air between ambient temperatures of 45 deg F and 115 deg F. Unit shall be able to operate and produce heated air between ambient conditions of 0 deg F and 70 deg F. Unit shall be able to operate with supply air temperatures between 50 deg F and 125 deg F; and with room temperature setpoints between 65 deg F and 85 deg F.
- G. Alternate Manufacturers: The project has been designed around units by the manufacturer scheduled on the drawings. Alternate manufacturers may be used (see Acceptable Manufacturers, Paragraph 2.01 and Section 20 05 00); however, any redesign (from what is shown on the drawing) to mechanical, electrical, structural or general construction to accommodate such an alternate manufacturer shall be provided by the Contractor. Furthermore, such redesign shall meet the requirements and have the approval of the Architect/Engineer prior to fabrication. Contractor shall submit complete shop drawings showing all alternate unit installation plans and details; shop drawings shall comply with Section 20 05 00. The redesign shall be equal or superior in all respects to the Architect/Engineer's design, including such aspects as equipment access, ease of maintenance, duct connection locations, unit electrical requirements, noise considerations, unit performance, and similar concerns. Cost of redesign and all additional costs incurred to accommodate alternate manufacturers shall be borne by the Contractor.

1.05 WARRANTY

- A. General: Entire unit shall be warranted to be free of all manufacturing defects and meeting all Contract Document requirements for a period of one year after Owner project acceptance.
- B. Compressors: Unit compressors shall be warranted by the manufacturer for five years after Owner project acceptance. All labor and materials associated with compressor replacement and repair shall be warranted.

1.06 REFERENCES

- A. AHRI 210/240: Performance Rating of Unitary Air-Conditioning & Air-Source Heat Pump Equipment.
- B. ASME B16.22: Standard for Wrought Copper and Copper Alloy Solder Joint Pressure Fittings.
- C. ASME B16.26: Standard for Cast Copper Alloy Fittings for Flared Copper Tubes.
- D. ASTM B280: Standard Specification for Seamless Copper Tube for Air Conditioning and Refrigeration Field Service.
- E. ANSI/AHRI 270: Sound Rating of Outdoor Unitary Equipment.

PART 2 PRODUCTS

2.01 ACCEPTABLE MANUFACTURERS

- A. All products shall comply with Section 20 05 00, Paragraph 2.01, Acceptable Manufacturers.
- B. Air Conditioning Units: Mitsubishi, Trane, Carrier, Daikin, LG.
- C. Refrigerant Pipe and Fittings: Domestic manufacturers only.

2.02 HEAT PUMP UNIT

- A. Type: Split system ductless heat pump.
- B. Indoor Unit: Ceiling suspended unit (configuration as indicated on plans), with fan, adjustable discharge outlet, air filter, evaporator coil, refrigerant metering device, heavy gauge steel chassis, white plastic enclosure, controls, condensate pan and drain connection, and related

accessories to operate properly with outdoor unit. Unit shall have dip switches adjusting fan speeds during different operating modes and when thermostat is satisfied.

- C. Outdoor Unit: Outdoor condenser and compressor unit, with high efficiency rotary compressor, condenser coil, condenser fan, accumulator, refrigerant piping, wind baffle accessory, heavy gauge steel chassis, baked enamel finish steel cabinet, controls, coil guard, mounting legs, and related accessories to provide capacity indicated. Outdoor unit shall be for use with multiple indoor units.
- D. Capacity: As scheduled on drawings at the conditions indicated. Unit shall provide cooling down to 0 deg F ambient. Unit shall be able to operate with refrigerant runs up to 164 feet long. Shall be rated in accordance with AHRI standards.
- E. Refrigerant: Units shall be for use with refrigerant R-410A or R-407C.
- F. Electrical and Controls:
 - 1. General: Indoor and outdoor units shall be provided with all contactors, relays, wiring terminals, safety controls, microprocessor devices, and accessories to allow for complete unit operation requiring only connection of room controller, power, and interconnection between indoor and outdoor units.
 - 2. Room Controller: Electronic type, with liquid crystal display, touch pad for setting adjustment, room temperature sensor, on/off/auto functions, temperature setpoint, fan speed indicator, and self diagnostic display.
 - 3. Sequence of Operation:
 - a. General: System shall use manufacturer's controls to control all space indoor units and outdoor unit system components as a unified system. System shall provide the sequence of operation specified. System shall operate in either heating or cooling mode. Initially the outdoor unit's heating/cooling mode shall be determined and set based on outside air enthalpy conditions. Once all indoor units are satisfied and/or are in the same heating/cooling mode, the outdoor unit will switch between heating and cooling to satisfy the indoor units.
 - b. Occupied Mode:
 - 1) Fan shall run continuously.
 - 2) Unit shall cycle in heating or cooling operation as required to satisfy space thermostat.
 - 3) Cooling: Heat pump shall operate in cooling mode.
 - 4) Heating: Heat pump shall operate in heating mode.
 - c. Unoccupied Mode: Unit's fan and heating/cooling shall cycle on and off as required to maintain setback temperatures.
 - d. Mode Control: Units' mode of operation shall be determined by system internal logic controller time schedule and local thermostat time schedule override.
- G. Condensate Pump: Provide unit with condensate pump. Where not available internal to unit or as specified on drawings, provide external type, with holding tank, controls, and gpm capacity at least 4 times unit condensate rate, at 10 feet of head. Provide mounting assembly and accessories for completely connected and functioning unit.
- H. Condensate Overflow Safety Switch: Provide unit with condensate overflow safety switch.

2.03 REFRIGERANT PIPING AND ACCESSORIES

- A. Piping: Hard drawn ACR copper tubing per ASTM B280, Type L, with silver brazed joints and wrought copper fittings per ASME B16.22. Use only long radius elbows. Flared fittings (at equipment connections only) shall comply with ASME B16.26. Soft copper tubing may only be

used on runs less than 50-feet or where necessary (i.e. when routing through sleeves, or similar poor access areas).

- B. Sight Glass: Sight glass shall allow visual inspection of refrigerant flow and indicate refrigerant moisture content. Shall be double port type, solder end connections, for use with type of refrigerant of system being installed in, same size as tubing installed in. Henry type 3103 or equal.
- C. Isolation Valves: Brass ball valve, full port, rated for 700 psig and -40 deg F to 300 deg F. Compatible with refrigerant used with, UL listed, with rupture proof encapsulated stem, extended copper connections for ease in brazing. Provide in configuration (i.e. angle, straight, with access port) as required to suit application.

PART 3 EXECUTION

3.01 INSTALLATION

- A. General: Install in strict accordance with manufacturer's written instructions and code.
- B. Location and Arrangement: Install all equipment at locations and as shown on the drawings. Install so as to allow maximum access to unit. Prior to selecting unit final location, confirm that: proper unit clearances and access will be provided; no adverse airflow conditions are present; confirm location and installation details with other trades. Units shall be level and aligned with building walls. Set outdoor unit on concrete pad (or roof sleepers); anchor to pad (or sleepers).
- C. Complete Connections: Connect and install all items shipped loose with units; provide and connect all utilities and accessories as required for proper unit operation. See Section 23 21 28 for cooling coil condensate drain piping.
- D. Refrigerant Piping: Shall be silver brazed. Bleed dry nitrogen through piping during brazing to minimize oxidation. Keep all open ends of piping capped when not being worked. Soft copper shall have long radius bends; install without kinks or excess bends. Piping shall be routed concealed, except where routed outdoors and where noted. Piping shall be ran plumb and square to building walls, and in a neat professional manner. Provide sight glass in refrigerant liquid piping at outdoor unit.
- E. Refrigerant Valves: Provide isolation valves on refrigerant piping connections at the outdoor unit (unless unit has integral service valves). Provide valve with access port on larger volume systems to aid in system vacuum testing (or as required for other purposes).
- F. Refrigerant Charge: Units shall be checked for proper refrigerant charge and oil level and charged to proper levels after all leak testing and evacuation work has been completed. Refrigerant to be added to the system shall be delivered to the site in factory charged containers and charged into the system through a filter/drier.
- G. Cleaning: Units shall be thoroughly cleaned of all debris prior to operation. Units shall be clean and in new condition prior to Owner acceptance.
- H. Operation: Units shall not be operated until all construction activities that generate dust, dirt, fumes, or odors are complete; system checkout has occurred; and the Engineer has reviewed the system and granted approval.

3.02 LEAK TESTING AND EVACUATION

- A. Disconnect and isolate from the system any controls, relief valves, or other components that may be damaged by the test pressure.
- B. Connect oil-pumped, dry nitrogen to the system through a pressure reducing gauge manifold. Charge enough nitrogen into the system to raise the pressure to 140 psig (or as required by the local Code authority).

- C. Test all joints for leaks with a glycerin soap solution. Check the manifold gauge for any drop in pressure. Tap all solder/brazed connections with a rubber or rawhide mallet sufficiently hard to start any leak that might subsequently open from thermal expansion/contraction or vibration.
- D. Repair any leaks found by completely disassembling the connection, cleaning the fitting and remaking the connection. Re-test the system after repairs are made.
- E. When the above tests are successfully completed, allow the system to remain under test pressure (140 psig or as required by the local code authority) for 24 hours. Note the initial pressure and temperature. If the system pressure has not changed (when corrected to account for any change in temperature) the system may be considered free of leaks.
- F. When all testing is completed the system shall be completely evacuated of all air and moisture. Connect a vacuum pump to the system and evacuate the system to 500 microns, and let stand for a minimum of 12 hours. If the vacuum reading remains unchanged, the system may be charged with refrigerant.

3.03 START-UP

- A. Initial Checks: Prior to unit operation, the system shall be inspected to ensure all equipment and controls are properly connected and ready to operate. As a minimum, the following items shall be checked.
 - 1. Adequate refrigerant charge.
 - 2. Gauges installed to read suction and discharge pressure.
 - 3. Proper voltage at outdoor unit.
 - 4. Proper voltage at indoor unit.
 - 5. Unit safeties properly set and connected.
 - 6. Fan motors lubricated and ready to operate.
 - 7. Temperature controls connected.
 - 8. Pipe leak testing completed.
 - 9. Condensate drain installed.
 - 10. System service valves in proper position.
 - 11. Controls properly connected and powered.
- B. Initial Operation: After start-up, check unit for proper unit operation including: proper fan rotation, no excessive vibration, no unusual noises, proper unit cycling in response to room temperature, no excessive room temperature swings, no safeties or electrical devices tripping out.
- C. Written Report: Submit written report detailing all inspection procedures and findings leak test results, amount refrigerant charge installed, and final start-up/operation results.

END OF SECTION

SECTION 23 81 45
SPLIT SYSTEM HEAT PUMP - DUCTED

PART 1 GENERAL

1.01 RELATED DOCUMENTS

- A. Drawings and general provisions of the Contract, including General and Supplementary Conditions and Division 00 and Division 01 Specification Sections, apply to this Section.
- B. Requirements of Section 20 05 00 apply to this Section.

1.02 WORK INCLUDED

- A. Split System Air Source Heat Pumps.
- B. Refrigerant Piping and Accessories.

1.03 SUBMITTALS

- A. Product Data: Submit complete product information on all units; include performance data showing cooling and heating capacity (as a function of indoor and outdoor coil db/wb temperatures and indoor coil air flow rates), supplementary heater capacity, fan performance, filter information, unit accessories, wiring diagram, and point of connection of all utilities.
- B. Installation: Submit manufacturers installation instructions for units.

1.04 QUALITY ASSURANCE

- A. Listing: Units shall be UL listed and labeled.
- B. Ratings: Units cooling and heating performance shall be rated in accordance with ANSI/AHRI 210/240.
- C. Codes: Unit and accessories shall conform to applicable codes and standards. Unit efficiency shall comply with code (and exceed code as indicated).
- D. Operating Ability: Outdoor unit and all components shall be able to withstand ambient temperatures from 0 deg F to 125 deg F, plus direct exposure to sun and weather elements without adverse affects. Unit shall be able to operate and produce cooled air between ambient temperatures of 45 deg F and 115 deg F. Unit shall be able to operate and produce heated air between ambient conditions of 0 deg F and 80 deg F. Unit shall be able to operate with supply air temperatures between 50 deg F and 125 deg F; and with room temperature setpoints between 65 deg F to 85 deg F.
- E. Electrical: Coordinate equipment electrical voltage/phase, minimum circuit amps, and overcurrent protection requirements with the Division 26 contractor prior to ordering.

1.05 GENERAL REQUIREMENTS

- A. Refrigerant Pipe Sizing: Refrigerant pipe sizes shown on the drawings are preliminary only. Due to the use of proprietary selection criteria by equipment manufacturers verify and finalize all required pipe sizes with the equipment manufacturer (or manufacturer's representative) prior to bidding. Verify with the equipment manufacturer (or manufacturer's representative) the need for any accumulators, solenoid valves, and similar accessories and size/select such devices prior to bidding. Include costs in bid for required pipe sizes and all accessories.
- B. Extended Warranties: Unit compressors shall be warranted by the manufacturer for five years. All labor and materials associated with compressor replacement (or repair) shall be warranted.

- C. Spare Parts: Filters: Provide two complete spare sets of filters for each unit.

1.06 REFERENCES

- A. ANSI/AHRI 210/240: Performance Rating of Unitary Air Conditioning & Air-Source Heat Pump Equipment.
- B. ANSI/AHRI 270: Sound Rating of Outdoor Unitary Equipment.
- C. ANSI/ASHRAE 52.2: Method of Testing General Ventilation Air-Cleaning Devices for Removal Efficiency by Particle Size.
- D. ASME B16.22: Standard for Wrought Copper and Copper Alloy Solder Joint Pressure Fittings.
- E. ASME B16.26: Standard for Cast Copper Alloy Fittings for Flared Copper Tubes.
- F. ASTM B280: Standard Specification for Seamless Copper Tube for Air Conditioning and Refrigeration Field Service.

PART 2 PRODUCTS

2.01 ACCEPTABLE MANUFACTURERS

- A. Products shall comply with Section 20 05 00, See Section 20 05 00, paragraph 2.01 for Acceptable Manufacturer requirements.
- B. Heat Pumps: Trane, Carrier, Mitsubishi, York/JCI.
- C. Condensate Safety Switch: Little Giant, Diversitech, Rectorseal.
- D. Refrigerant Piping and Accessories: Mueller, Sporlan, Nibco, Elkhart, Parker, Emerson, Henry.

2.02 SPLIT SYSTEM HEAT PUMP - OUTDOOR UNIT

- A. Type: Split system air-to-air heat pump; outdoor section.
- B. Capacity: Units shall have minimum cooling and heating capacities as scheduled on the drawings at the conditions shown and with the indoor unit (i.e., air handler) indicated; and shall be rated in accordance with ARI standards.
- C. General: Unit shall be fully factory assembled and shall be complete with casing, coils, fans, compressor(s), piping, wiring, controls, and all other accessories required to be ready for field connections and operation. Units shall be UL listed and labeled. Units control wiring shall be 24 volt, and units shall be capable of operating in the cooling mode from 40 to 115 degrees F ambient, and in heating mode from -20 to 65 degrees F ambient.
- D. Factory Test: Units shall be factory run-tested to verify proper heating, cooling, defrost, control, and fan operation.
- E. Refrigerant: Units shall be for use with refrigerant R-410A and shall be fully charged at the factory.
- F. Unit Casing: Shall be constructed of minimum 18 gauge zinc coated steel, with zinc phosphate coating and baked-on polyester powder coating. Access panels shall provide access to unit controls and all major components. All screws or holding devices shall be of cadmium plated construction to resist corrosion. Unit shall have knockouts for piping, electrical and control connections with rubber grommets to insure water-proof connections.
- G. Compressor(s): Hermetically sealed or serviceable hermetic reciprocating type compressor, specifically designed for heat pump service. Compressor shall have internal line break overcurrent and overtemperature protection, low pressure protection (via low pressure switch), high pressure protection (via internal relief valve or pressure switch), and crankcase heaters.

Motor shall be suction gas cooled and have a voltage utilization range of plus or minus 10% of nameplate voltage. Compressor(s) shall have internal spring isolation mounting and discharge gas sound muffler to reduce vibration transmission and noise.

- H. Refrigerant Circuit: Shall be fully factory piped and shall include a refrigerant line filter/drier, liquid line and gas line service valves (brass, back seating type) with service ports, reversing valve, accumulator, and thermostatic expansion valve for both heating and cooling operation.
- I. Coils: Shall be constructed of seamless copper tubing with aluminum fins mechanically bonded to tubes.
- J. Fan(s): Shall be statically and dynamically balanced at factory. Shall be propeller type, used in draw-through configuration, direct drive type, with permanently lubricated, totally enclosed weather-proof ball bearing type motor(s) having built-in overload protection.
- K. Defrost: Unit shall have defrost cycle to remove build-up of frost on outdoor coil. Defrost cycle shall be an on-demand time and temperature initiated; i.e., after 90 minutes (adjustable to lower time periods) elapsed run time; if temperature is low enough, defrost cycle shall be activated. Defrost cycle shall be time or temperature terminated; i.e., defrost cycle shall stop after 10 minutes or when refrigerant temperature is high enough indicating defrost is completed. When in defrost mode, unit shall provide an output (normally open dry contacts) to building control system to allow Section 23 09 33 controls to activate supplementary electric heaters as needed. Unit shall also have defrost control in case of low evaporator coil temperatures at the indoor coil; unit shall prevent compressor slugging by temporarily interrupting compressor operation.
- L. Electrical Power: Units shall be for use with power of voltage and phase as scheduled on the drawings.
- M. Accessories:
 - 1. Anti-Short-Cycle-Timer: Solid state 24 volt timing device to prevent rapid on-off compressor cycling; providing an approximate 5 minute delay between compressor starts.
 - 2. Low Ambient Accessories: Provide unit with accessories as needed to allow operation to temperatures specified in Paragraph C above. Accessories shall include head pressure control device(s), evaporator freeze thermostat, low ambient isolation relay.
 - 3. Compressor Start Assist: Provide capacitor(s) and relay(s) to allow improved compressor starts.
 - 4. Mounting Legs: Provide with minimum 4" high non-corroding mounting legs (or base), to allow for proper drainage of unit base and to minimize base corrosion.

2.03 SPLIT SYSTEM HEAT PUMP - INDOOR UNIT

- A. Type: Split system heat pump, indoor section (i.e. air handler). Air flow configuration as indicated on drawings.
- B. Capacity: Units shall have minimum cooling and heating capacities as scheduled at the conditions shown and with the outdoor unit indicated, and shall be rated in accordance with AHRI standards.
- C. General: Units shall be fully factory assembled and shall be complete with casing, coils, fans, piping, wiring, controls, supplementary electrical heaters and all other accessories required to be ready for field connections and operation. Unit shall be compatible with outdoor section as specified so as to provide performance over the temperature range indicated.
- D. Refrigerant Circuit: Shall be fully factory piped and shall include factory installed thermostatic expansion valve (or dual flow metering device) to allow for both heating and cooling operation.
- E. Unit Casing: Shall be constructed of zinc coated steel, with baked-on enamel finish. Access panels shall provide access to unit controls, indoor coil, supply air fan, and filters. Unit shall be

completely insulated with minimum 1" thick 1-1/2 lb. per cubic foot neoprene coated fiberglass insulation. Condensate drain pan shall be provided with external connections on either side of unit.

- F. Refrigerant Circuit: Shall be fully factory piped and shall include factory installed thermostatic expansion valve (or dual flow metering device) to allow for both heating and cooling operation.
- G. Coils: Shall be constructed of seamless copper tubing with aluminum fins mechanically bonded to tubes.
- H. Fans: Shall be statically and dynamically balanced at factory. Shall be double width, double inlet, forward curved centrifugal type, with adjustable belt drive or multi-speed direct drive type, as follows:

<u>Fan Scheduled CFM</u>	<u>Drive</u>
0-1899	Direct
1900-2200	Direct or Belt
2201 and up	Belt

Direct drive fans shall have minimum of three speeds, field changeable by switching wiring connections at unit terminal strip or by operation of switches or equivalent method. Belt drive units shall have adjustable sheaves. Fan and motor bearings shall be permanently lubricated type with built-in overload protection.

- I. Air Filters:
 - 1. General: Unit shall be provided with filter racks for accommodating filter sizes as scheduled on the plans (except where filters are indicated to be installed at another location).
 - 2. Filter Type: Shall be pleated panel, disposable type. Filter shall have MERV 8 efficiency as evaluated by ASHRAE 52.2.
- J. Defrost: In conjunction with outdoor unit, unit shall have defrost control to prevent compressor slugging by temporarily interrupting compressor operation in case of low evaporator coil temperatures.
- K. Supplementary Electric Heaters: Shall be provided with capacity and stages as scheduled on the drawings at the voltage and phase indicated. Heaters shall have open wire nickel-chrome elements, mercury contactors, stages as indicated, safety overcurrent protection, and secondary and primary overtemperature protection. Heaters shall have airflow switch (or be interlocked to fan starting device) to only allowing heater operation when airflow is proven. Heaters shall be UL listed.
- L. Electrical Power: Units shall be for use with power of voltage and phase as scheduled on the drawings. Units shall have single power entry unless indicated otherwise. Units with single source power entry shall require only one field connection and power source. All necessary terminal block, fuse blocks, fuses, wiring, junction boxes and accessories shall be factory installed within the unit cabinet to provide power to all devices (including the supplementary heater for single source power entry units).
- M. Vibration Isolators: Neoprene-in-shear (or spring suspension) type. All isolators shall be sized by manufacturer for unit weights and so as to provide 95% vibration isolation efficiency.
- N. Condensate Safety Switch: Code compliant safety switch for stopping unit operation at high condensate level. PVC or polymer body, with corrosion resistant mechanical float or reed switch, normally closed contacts, minimum 2.5 amp capacity at 24 vac, and 6 feet 18 gauge wire leads Little Giant ACS-5 (or approved equal).

2.04 REFRIGERANT PIPING AND ACCESSORIES

- A. Piping: Hard drawn ACR copper tubing per ASTM B280, Type L, with silver brazed joints and wrought copper fittings per ASME B16.22. Use only long radius elbows. Flared fittings (at

equipment connections only) shall comply with ASME B16.26. Soft copper tubing may only be used on runs less than 50-feet or where necessary (i.e. when routing through sleeves, or similar poor access areas).

- B. Sight Glass: Sight glass shall allow visual inspection of refrigerant flow and indicate refrigerant moisture content. Shall be double port type, solder end connections, for use with type of refrigerant of system being installed in, same size as tubing installed in. Henry type 3103 or equal.
- C. Isolation Valves: Brass ball valve, full port, rated for 700 psig and -40 deg F to 300 deg F. Compatible with refrigerant used with, UL listed, with rupture proof encapsulated stem, extended copper connections for ease in brazing. Provide in configuration (i.e. angle, straight, with access port) as required to suit application.
- D. Filter/Drier: Sealed cannister type, with molded blended desiccant core, for filtering refrigerant system moisture, debris and acids. Suitable for refrigerant and system type used with. Size for maximum 1 psi pressure drop. Sporlan "Catch-All" (or approved).

PART 3 EXECUTION

3.01 INSTALLATION

- A. General: Comply with Section 20 05 00. Install in accordance with Manufacturer's written instructions, code, applicable standards and best construction practices. Indoor Units shall be level (or slightly sloped) to drain and aligned with building walls. All indoor units shall be hung from the building structure (unless noted otherwise). Provide custom fabricated steel support frames as necessary. Install indoor units with vibration isolators.
- B. Location Verification: Install equipment in locations as indicated in accordance with the Contract Documents. Prior to selecting installation locations, confirm that: unit location matches ductwork for the area the unit is intended to serve; installed duct locations match unit; manufacturer's pre-installation checks have been completed; proper unit clearances and access will be provided; no adverse conditions will affect unit operation at the proposed location and arrangement present; and installation has been coordinated with other trades.
- C. Complete Connections: Connect and install all items shipped loose with units; provide and connect all utilities and accessories as required for proper unit operation.
- D. Refrigerant Piping: Shall be silver brazed. Bleed dry nitrogen through piping during brazing to minimize oxidation. Keep all open ends of piping capped when not being worked. Soft copper shall have long radius bends; install without kinks or excess bends. Piping shall be routed concealed, except where routed outdoors and where noted. Piping shall be ran plumb and square to building walls, and in a neat professional manner. Provide sight glass in refrigerant liquid piping at outdoor unit.
- E. Refrigerant Valves: Provide isolation valves on refrigerant piping connections at the outdoor unit (unless unit has integral service valves). Provide valve with access port on larger volume systems to aid in system vacuum testing (or as required for other purposes).
- F. Refrigerant Charge: Units shall be checked for proper refrigerant charge and oil level and charged to proper levels after all leak testing and evacuation work has been completed. Refrigerant to be added to the system shall be delivered to the site in factory charged containers and charged into the system through a filter/drier.
- G. Cleaning: Units shall be thoroughly cleaned (internally and externally) of all debris prior to operation. Units shall be clean and in new condition prior to Owner acceptance.
- H. Operation and Maintenance:

1. General: Operation and Maintenance shall be in accordance with manufacturer's written procedures and recognized best maintenance practices. Keep records of maintenance and (upon request) forward to the Architect/Engineer prior to project final acceptance.
 2. Stored Products: Provide maintenance (i.e. equipment rotation, lubrication, flush, cleaning, etc.) and inspection on products while stored to maintain new condition.
 3. Installed Products: Provide maintenance and inspection of products and operate mechanical systems until substantial completion or specified Owner Instruction has been provided (whichever is later). Maintenance shall include all manufacturer's recommended maintenance (i.e. strainer cleaning, filter changes, bearing lubrication, belt tensioning, etc.). In addition to scheduled maintenance, review all equipment periodically to allow detection of improper operation or any special maintenance needs; review shall be consistent with best practices for the product but in no case less than every two weeks.
 4. Units shall not be operated until all construction activities that generate dust, dirt, fumes, or odors are complete. Units shall not be placed into service until start-up has been completed.
- I. Owner Instruction: Instruct Owner on equipment operation, including: system start-up, shut-down, emergency shut-down, normal control operation, safety aspects, maintenance and repair instructions.

3.02 REFRIGERANT LEAK TESTING AND EVACUATION

- A. Notification/Witnessing: Prior to beginning any testing, notify the Architect/Engineer when the testing will occur. The Architect/Engineer will witness (at his discretion) various parts of the test. Failure to notify the Architect/Engineer will be cause to re-test all piping in the presence of a representative of the Architect/Engineer.
- B. Test Preparation: Disconnect and isolate from the system any components that may be damaged by the test pressure.
- C. Testing: Connect oil-pumped, dry nitrogen to the system through a pressure reducing gauge manifold. Charge enough nitrogen into the system to raise the pressure to 50 psig. Let stand for 2 hours and check for signs of leakage. If no leakage is noted, slowly increase pressure to 300 psig (or as required by local code, whichever is higher). Tap all brazed connections with a rubber or rawhide mallet sufficiently hard to start any leak that might subsequently open from thermal expansion/contraction or vibration. Check the manifold gauge for any drop in pressure. Let the system stand pressurized for 24 hours. Re-check the manifold gauge. If no change in pressure is noted (after adjusting for temperature) the system may be considered free of leaks.
- D. Leak Repair: If leakage is suspected or apparent, check joints with a glycerin soap solution or other means to locate the leaks. Repair any leaks found by completely disassembling the connection, cleaning the fitting and remaking the connection. Re-test the system after repairs are made both with pressure (300 psi for 24 hours) and at the leak location with a glycerin soap solution or other means of determining leaks.
- E. System Evacuation: When the system has been proven free of leaks with the above methods, the system shall be completely evacuated of all air and moisture. Connect a vacuum pump to the system and pump the system down to 500 microns and let stand for a minimum of 2 hours. If the vacuum reading remains unchanged, the system may be charged with refrigerant.
- F. System Charging: After satisfactory pressure testing and vacuum evacuation, fully charge the system with refrigerant. Any final connections that were not subject to the full test pressure (e.g. connections at unit, etc.) shall be carefully checked with a halide or electronic leak detector after the system has been charged.

3.03 START-UP

- A. Pre Start-Up Inspection: Inspect equipment and connecting systems to confirm equipment and connecting systems to confirm equipment has been installed properly and is ready for start-up. As a minimum, check for: proper voltage and phases, correct system refrigerant charge, correct electrical connections, complete control connections, all unit safety devices properly set and connected, heaters operational, fans free to rotate and rotating correctly, fans lubricated, belts tightened to proper tension, coils clear of obstructions, and other items as listed by the manufacturer are properly provided/connected and operating to ensure safe and proper start-up.
- B. Start-Up: Perform start-up in accordance with manufacturers written start-up procedures. Arrange other trades needed to be present (i.e. balancer, control technician, etc.). Operate equipment in various modes to confirm proper operation. Observe proper operation of all unit components (heating, cooling, condenser fan, economizer, etc.).
- C. Adjustments: Adjust and set unit components to allow for proper operation (i.e. adjust fan sheaves, adjust fan speeds, unit settings, etc.). Observe unit to detect any unusual vibration, leakage, loose wiring, or other situations that could affect unit operation.

END OF SECTION

SECTION 23 82 46
ELECTRIC HEATERS

PART 1 GENERAL

1.01 RELATED DOCUMENTS

- A. Drawings and general provisions of the Contract, including General and Supplementary Conditions and Division 00 and Division 01 Specification Sections, apply to this Section.
- B. Requirements of Section 20 05 00 apply to this Section.

1.02 WORK INCLUDED

- A. Electric Heaters.

1.03 SUBMITTALS

- A. General: Comply with Section 20 05 00.
- B. Product Data: Submit product information on all items.

1.04 GENERAL REQUIREMENTS

- A. Listing: All heaters shall be listed by an independent testing laboratory for the application indicated.
- B. Installation Verification: Prior to ordering units confirm finishes at heater location and type of installation and associated trim required; i.e. fully recessed, semi recessed, surface mount, etc.

PART 2 PRODUCTS

2.01 ACCEPTABLE MANUFACTURERS

- A. Products: Shall comply with Section 20 05 00 Part 2.01 - Acceptable Manufacturers.
- B. Wall Electric Heaters: Q-Mark, Chromalox, Berko, Markel.
- C. Duct Heaters: Indeeco, Berko, Markel, Q-Mark.

2.02 WALL HEATERS

- A. Type: Wall mounted electric forced air heater. Markel 3320 Series (or approved).
- B. Construction: Heater housing shall be constructed of minimum 18 steel, with an extruded aluminum frame; for surface or semi-recessed installation as shown on the drawings (or as required to suit construction). Unit shall have baked-on enamel or powder coat finish, dark brown.
- C. Heating Elements: Sealed tubular type with parallel steel fins, with capacity as scheduled.
- D. Motor and Fan: Motor shall be multi-pole, total enclosed, permanently lubricated type. Fan operating RPM shall not exceed 600.
- E. Electrical and Controls: Unit shall have automatic reset thermal limit, fan delay circuit, power disconnect switch, and integral thermostat. Thermostat shall be heavy duty snap action type with setting range from 55 to 85 deg F (unless indicated otherwise).
- F. Accessories:
 - 1. Surface or semi-recess mounting adapter to suit installation arrangement required.

2. 24 volt contactor for remote control of heater via remote low voltage thermostat or by building controls (i.e. night-setback control). Coordinate requirements with project control system.

2.03 DUCT ELECTRIC HEATERS

- A. Type: Open coil type electric duct heaters; of size and capacity as shown on the drawings.
- B. Listing: Heaters shall be UL listed for zero clearance to combustibles, and shall be built to meet all requirements of the National Electric Code and NFPA.
- C. Construction: Heating coils shall be made of 80% nickel and 20% chromium coiled resistance wire. Coils shall be supported in an aluminized steel frame and insulated by floating ceramic bushings. Heaters shall be of the configuration to suit the application as shown on the drawings.
- D. Overtemperature Protection: All heaters shall be equipped with primary and secondary overtemperature safety devices. The primary safety device shall be a disc or liquid filled bulb type with automatic reset; the secondary device shall be a disc type with manual reset, wired in series with each heater stage, set to trip at a higher temperature than the primary safety device.
- E. Overcurrent Protection: Fuses shall be provided for overcurrent protection; fuse capacities shall be rated for at least 125% of the circuit amperage.
- F. Proof of Air Flow: Where project's control system is the DDC type, and heater is controlled by the DDC, proof of airflow is to be provided via the DDC system; no proof of airflow devices are required to be furnished integral with the heater. For non-DDC control systems or where the DDC control system is not providing heater control, provide heater with differential air pressure device and sensing tube (or sail flow switch), interlocked with the heater to prevent heater operation in case of insufficient airflow across the coil. Differential air pressure device (or sail flow switch) shall have sufficient sensitivity to suit velocity and duct pressures of the application. Configure and arrange differential air pressure device (or sail flow switch) for proper operation as the application requires. Air differential air pressure device shall have a pitot tube on high pressure side installed to sense duct total air pressure; except where heater is used on the suction side of a fan, the air differential air pressure device shall be connected to the low pressure side and be configured sensor to measure static pressure only. Where sensitive enough differential air pressure devices (or sail flow switches) are not available, provide heater with 24 volt relay for interlocking to a fan proof device (i.e. motor starter auxiliary contacts, fan start relay, or equivalent).
- G. Terminal Box: All heater controls shall be mounted in a side mounted terminal box, unless a separate remote mounted terminal box is shown on the drawings. Terminal box shall be insulated from the heater casing.
- H. Disconnect: Heaters shall be provided with a built-in power disconnect switch, having a terminal door interlock.
- I. Controls: Heaters shall be furnished with 24 volt transformer and shall be for use with 24 volt controls unless indicated otherwise. Transformer shall have secondary fusing, and transformers which are not class 2 shall have primary fusing. Mercury control contactors shall be used for controlling heater stages unless indicated otherwise. Where SCR control has been indicated the heater shall be furnished with a solid state proportional power controller allowing modulation of heater capacity from 0 to 100% of full capacity. The SCR control shall energize the heater only for the number of AC cycles necessary to produce the amount of heat required. For heaters with loads greater than 90 amps SCR control combined with a step controller in a vernier configuration (still providing full proportional control) is acceptable. (Backup or safety contactors - where used - shall be magnetic type).
- J. Electrical: Heaters shall be for use with electricity of the voltage and phase indicated, and provide the output and number of control stages indicated. Three phase heaters shall have

equal balanced three phase circuits. Heater element circuits shall be subdivided so that no circuit load exceeds 48 amperes. All internal wiring shall be suitable for 220 degrees.

PART 3 EXECUTION

3.01 INSTALLATION

- A. General: Comply with Section 20 05 00. Install in accordance with manufacturer's written instructions, code, applicable standards and best construction practices.
- B. Coordination: Coordinate heater power and control requirements with other trades; confirm location of any required heater contactors, relays, thermostats, and similar devices. Provide any required wiring for proof of fan operation between fan devices and heater; wiring shall comply with the HVAC control portion of the specifications and Division 26.
- C. Location and Trim Verification: Install equipment at locations indicated in accordance with the Contract Documents. Review and confirm installation locations, that proper clearances are provided, unit controls are accessible, and installation has been coordinated with other trades.
- D. Complete Connections: Connect and install all items shipped loose with units; provide and connect all contactors, relays, wiring, interconnections and accessories as required for proper unit operation.
- E. Cleaning: Units shall be thoroughly cleaned (internally and externally) of all debris prior to operation. Units shall be clean and in new condition prior to Owner acceptance.
- F. Owner Instruction: Instruct Owner on equipment operation and maintenance.

3.02 START-UP

- A. Pre Start-Up Inspection: Inspect equipment and connecting systems to confirm equipment and connecting systems to confirm equipment has been installed properly and is ready for start-up. As a minimum, check for: proper voltage and phases, correct electrical connections, complete control connections, all unit safety devices properly set and connected, coils clear of obstructions, and other items as listed by the manufacturer are properly provided/connected and operating to ensure safe and proper start-up. If items are discovered that prevent start-up to be completed, notify the installing Contractor and Engineer of issues. Coordinate and re-schedule start-up after items are corrected.
- B. Start-Up: Perform start-up in accordance with manufacturers written start-up procedures. Observe proper operation of all unit components.
- C. Adjustments: Adjust and set unit components to allow for proper operation. Observe unit to detect any unusual vibration, leakage, loose wiring, or other situations that could affect unit operation.

END OF SECTION

HEAT PUMP SCHEDULE - SPLIT SYSTEM TYPE

SYMBOL	BASIS OF DESIGN MANUFACTURER AND SERIES NO.	AREA SERVED	COOLING CAP. *			HEATING CAP. **		A - INDOOR UNIT ***						B - OUTDOOR UNIT ***						FILTERS		MIN. OA CFM	MAX. OUTDOOR UNIT WEIGHT	MAX. INDOOR UNIT WEIGHT	PIPE SIZE		REMARKS			
			TOTAL MBH	SENSIBLE MBH	EFF	MBH	EFF	FAN		HEATER		TOTAL ELECTRIC		COMPRESSOR		FAN		ELECTRICAL		TYPE	MIN. SF				RG	RL				
			CFM	ESP	HP/WATTS	KW	STAGES	MCA	MOP	VOLTS / PH	QTY	RLA (EA)	QTY	HP/WATTS	MCA	MOP	VOLTS/PH													
HP-4	DAIKIN PVA-A42 PUZ-A42	COMMUNITY MEETING ROOM 114	42	34	18 SEER	46	3.45	1480	.8	430 W	10	2	57.7	60	240/1	1	8	2	74 W + 74 W	25	30	240/1	MERV 8	4 SF	100	250	200	5/8"	3/8"	① ② ③ ④ W/ 0-100% OA ECONOMIZER, W/ HEATER KIT EH10-MPA-L(B)

* COOLING CAPACITY IS AHRI RATING: AT 85° F DB; 66° F WB INDOOR COIL EAT AND 95° F OUTDOOR COIL EAT.
 ** HEATING CAPACITY IS AHRI HI-TEMP RATING: AT 70° F DB INDOOR EAT AND 47° F DB; 43° F WB OUTDOOR COIL EAT.
 *** ON PLANS "A" DESIGNATES INDOOR UNIT, "B" DESIGNATES OUTDOOR UNIT. (E.G. HP-1B IS HP-1 OUTDOOR UNIT).

NOTES: ① FILTERS INSTALLED IN CONTRACTOR FABRICATED FILTER SECTION; SEE PLAN. ② W/ CO2 DCV. ③ W/ LOW AMBIENT KIT. ④ PROVIDE SINGLE POINT POWER CONNECTION FOR INDOOR UNIT & HEATER.

AIR INLET & OUTLET SCHEDULE

SYMBOL	TYPE	MANUFACTURER AND SERIES NUMBER	REMARKS
CD	CEILING DIFFUSER	KRUEGER SERIES 1240	MODULAR CORE, SQUARE NECK W/ STRAIGHTENING GRID
VG	VENTILATION GRILLE	LIFEBREATH TECHGRILLE	PROVIDE W/ MOUNTING ACCESSORIES
CER	CEILING EXHAUST REGISTER	KRUEGER SERIES EGC-5	1/2"x1/2"x1/2" CUBE CORE W/ OBD
TG	TRANSFER GRILLE	KRUEGER SERIES EGC-5	1/2"x1/2"x1/2" CUBE CORE
WL	WALL LOUVER	RUSKIN ELF375DX	4" DEEP, EXTRUDED ALUMINUM
WRG	WALL RETURN GRILLE	KRUEGER SERIES S580H	HORIZ. FACE BARS 3/4" O.C., 35° DEFLECTION

NOTES:
 1. CEILING DIFFUSERS (CD) SHALL HAVE NO. & DIRECTION OF THROWS AS INDICATED ON PLANS. (E.G. CD-3 = 3 WAY THROW)
 2. ALL AIR INLETS/OUTLETS SHALL HAVE FACTORY FINISH, COLOR AS SELECTED BY ARCHITECT.
 3. SEE LEGEND FOR TERMINOLOGY USED IN AIR INLETS/OUTLETS CALL-OUTS ON DRAWINGS.
 4. SEE ARCHITECTURAL FINISH SCHEDULE FOR CEILING TYPES, PROVIDE AIR TERMINALS TO MATCH CEILING CONSTRUCTION INSTALLED IN.

MULTI-ZONE INDOOR HEAT PUMP SCHEDULE

SYMBOL	BASIS OF DESIGN MANUFACTURER AND SERIES NO.	TYPE	AREA SERVED	SERVED BY	CAPACITY (MBH)		CFM	ESP	FILTERS	UNIT ELECTRICAL			REFRIGERANT PIPE SIZE	OA (CFM)	MAX WEIGHT	REMARKS
					COOLING	HEATING				MCA	MOP	VOLT/PH				
FC-108	DAIKIN PLFY-P05	CEILING CASSETTE	ADMIN - 108	HP-3	5	5.5	280	-	MFR STD	0.24	15	240/1	1/4" - G 1/2" - L	-	50	W/ ME CONTROLLER
FC-109	DAIKIN PLFY-P05	CEILING CASSETTE	CHIEF - 109	HP-3	5	5.5	280	-	MFR STD	0.24	15	240/1	1/4" - G 1/2" - L	-	50	W/ ME CONTROLLER
FC-112	DAIKIN PLFY-P05	CEILING CASSETTE	SLEEPING - 112	HP-3	5	5.5	280	-	MFR STD	0.24	15	240/1	1/4" - G 1/2" - L	-	50	W/ ME CONTROLLER
FC-113	DAIKIN PLFY-P05	CEILING CASSETTE	SLEEPING - 113	HP-3	5	5.5	280	-	MFR STD	0.24	15	240/1	1/4" - G 1/2" - L	-	50	W/ ME CONTROLLER
FC-115	DAIKIN PLFY-P12	CEILING CASSETTE	KITCHEN - 115	HP-3	12	13.5	335	-	MFR STD	0.29	15	240/1	1/4" - G 1/2" - L	-	50	W/ ME CONTROLLER

MULTI-ZONE OUTDOOR HEAT PUMP SCHEDULE

SYMBOL	BASIS OF DESIGN MANUFACTURER AND SERIES NO.	AREA SERVED	COOLING CAP. *		HEATING CAP. **		OUTDOOR FAN	COMPRESSOR	MAX. WEIGHT LBS	UNIT ELECTRICAL			REMARKS
			TOTAL MBH	EFF (EER / SEER)	MBH	EFF (COP)				QTY	QTY	MCA	
HP-3	DAIKIN S SERIES PUMY-P36	TI SPACE - OFFICES, BEEDROOMS & KITCHEN	36	15.0 / 22.3	42	4.0	1	1	300	29	40	240/1	W/ WIND BAFFLE

* COOLING CAPACITY IS AHRI RATING: AT 80° F DB; 67° F WB INDOOR COIL EAT AND 95° F OUTDOOR COIL EAT. ** HEATING CAPACITY IS AHRI HI-TEMP RATING: AT 70° F DB INDOOR COIL EAT AND 47° F DB; 43° F WB OUTDOOR COIL EAT.

PLUMBING FIXTURE SCHEDULE

SYMBOL	DESCRIPTION	W	V	CW	HW	REMARKS
P-1A	WATER CLOSET	4"	2"	1/2"	-	FLOOR MOUNT, TANK TYPE, ADA ACCESSIBLE
P-1B	WATER CLOSET	4"	2"	1/2"	-	FLOOR MOUNT, TANK TYPE
P-3A	LAVATORY	1-1/2"	1-1/2"	1/2"	1/2"	COUNTERTOP ADA ACCESSIBLE
P-5A	KITCHEN SINK	2"	2"	1/2"	1/2"	DOUBLE COMPARTMENT
P-6A	SERVICE SINK	2"	2"	1/2"	1/2"	FLOOR MOUNT
P-11A	FLOOR DRAIN	2" *	2" *	-	-	W/ TRAP PRIMER

* UNLESS NOTED OTHERWISE ON DRAWINGS

DOAS HEAT RECOVERY UNIT

SYMBOL	BASIS OF DESIGN MANUFACTURER AND SERIES NO.	AREA SERVED	SUPPLY FAN				EXHAUST FAN				UNIT ELECTRICAL			FILTERS		MAX UNIT WEIGHT (LBS)	REMARKS	
			TYPE	CFM	ESP	RPM	TYPE	CFM	ESP	RPM	WATTS	MCA	MOP	VOLTS/PH	TYPE			MIN. SF
HRV-1	LOSSNAY LGH-F300RVX	TI SPACE	DIRECT DRIVE	300	0.5"	--	DIRECT DRIVE	270	0.5"	--	155	2	15	240/1	MFR STD	--	100	

NOTES: 1. UNITS SHALL HAVE MINIMUM 50% ENTHALPY HEAT RECOVERY PER WSEC AT EXHAUST AIR OF 70°F, 30% RH & EAT OF 20°F, 90% RH. 2. PROVIDE UNITS OA & EA WITH MOTORIZED DAMPERS COMPLYING W/ WSEC.

ELECTRIC HEATER SCHEDULE

SYMBOL	BASIS OF DESIGN MANUFACTURER AND SERIES NO.	TYPE	AREA / UNIT SERVED	ELECTRICAL		NOMINAL SIZE	STAGES	CFM	REMARKS
				KW	VOLTS/PH				
DH-1	INDEECO QUA	DUCT HEATER	HRV-1	2.5	240/1	10"x10"	SCR	300	①
EH-1	QMARK CWH1101DSAF	WALL HEATER	HALLWAY	1	120/1	-	1	-	RECESSED ②

① HEATER SHALL BE INTERLOCKED WITH THE FAN SERVED BY, SUCH THAT HEATER MAY ONLY OPERATE WHEN FAN IS PROVEN ON. HEATER PRESSURE SWITCH SHALL NOT BE UTILIZED.
 ② PROVIDE W/ INTEGRAL THERMOSTAT.

OA VENTILATION CALCULATION PER IMC 2015

Date: 3/31/20
Calc By: LS

Project: Mossyrock Fire Station
No: 20-048

Az = zone area
sf = square feet
Rp = OA per person*
P/1000 sF = People density
Ps = zone population
Ps = actual concurrent pop

Ra = OA per sf of area
Vbz = breathing zone OA
= Rp*P/1000 + Ra*Az
= OA before corrections
Ez = air distrib effectiveness
Voz = zone OA = Vbz/Ev

HVAC Unit	Zone #	Name	Occup Category	Az (sf)	People OA				Area OA		OA Vbz	Ez	Voz (cfm)	V Selected (cfm)	
					Rp	P/1000 sf	Pz	Rp*Pz	Ra	Ra*Az					
HRV-1	1	Kitchen 115	Kitchen	215	0	0	0	0.0	0.3	64.5	64.5	1	64.5	70	
	2	Lobby/Comdor 107	Corridor	470	0	0	0	0.0	0.06	28.2	28.2	1	28.2	130	
	3	Admin 108	Office	185	5	5	1	5.0	0.06	11.1	16.1	1	16.1	25	
	4	Chief 109	Office	200	5	5	1	5.0	0.06	12.0	17.0	1	17.0	25	
	5	Sleeping 112	Office	119	5	5	1	5.0	0.06	7.1	12.1	1	12.1	25	
	6	Sleeping 113	Office	119	5	5	1	5.0	0.06	7.1	12.1	1	12.1	25	
System Actual Population Ps = 4															
No Zones: 6				1308			4.0	20.0		130.1			150.1	300	
FC-114	1	Meeting Room 100	Meeting Room	1408	5	30	43	215.0	0.06	84.5	299.5	0.8	374.4	375	
System Actual Population Ps = 43															
No Zones: 1				1408			43.0	215.0		84.5			299.5	374.4	375



525 COLUMBIA ST. | OLYMPIA, WA 98501
360.915.8775 | tosolympia.com



1111 Fairwatt Ave Suite 100 Tacoma, WA 98402
Phone: (253) 383-3257 Fax: (253) 383-3283
general@hultzbhuc.com Job Number: 20-048



SIGNED
04/15/2020

LEWIS COUNTY FIRE DISTRICT #3
MOSSYROCK FIRE STATION
238 MOSSYROCK ROAD E | MOSSYROCK, WA 98564

Project No: 1927
CONSTRUCTION DOCUMENTS
OCTOBER 2, 2020

ADDENDUM 1 10.02.2020

MECHANICAL SCHEDULES

M1-2

All material herein constitutes the original and unpublished work of the architect and may not be used, duplicated, or disclosed without the written consent of the architect. Copyright © 2020 by Thomas Architecture Studio. All rights reserved.



SIGNED
04/15/2020

GENERAL NOTES

- SEE MECHANICAL GENERAL NOTES SHEET M1-1.
- FOR PIPE SIZES TO INDIVIDUAL PLUMBING FIXTURES SEE "PLUMBING FIXTURE SCHEDULE", SHEET M1-2.
- LOCATE ALL ISOLATION & BALANCING VALVES TO BE EASILY ACCESSIBLE.
- ROUTE PIPING SO AS NOT TO OBSTRUCT EQUIPMENT MAINTENANCE ACCESS.
- COORDINATE ALL FLOOR DRAIN LOCATIONS WITH GC AND OTHER TRADES PRIOR TO ROUGH-IN TO CONFIRM DRAINS WILL SERVE INTENDED ITEMS AND SUIT FLOOR SLOPE. SUBMIT A MARKED UP FLOOR PLAN SHOWING DIMENSIONED LOCATIONS OF ALL FLOOR DRAINS FOR REVIEW/COORDINATION PRIOR TO INSTALLATION.
- ALL VENTS ARE 2" (UNO).
- PROVIDE TEMPERATURE LIMITING VALVES ON ALL PUBLIC LAVATORIES.
- INSULATION IS AT CEILING LEVEL; ROUTE ALL PLUMBING PIPES ON HOT SIDE OF INSULATION.

KEYED NOTES

- 1/2" CW DN TO TRAP PRIMER VALVE.
- LOOP CIRCULATED HW DOWN IN WALL TO WITHIN 6" OF STOP VALVE TO FIXTURE.
- 1/2" CW TO REFRIGERATOR WALL BOX. PROVIDE 1/4" CW TO REFRIGERATOR.
- PROVIDE 1/2" HW CONNECTION & WASTE CONNECTION W/ AIR GAP FITTING FROM SINK TO ADJACENT DISHWASHER.
- ROUTE PLUMBING DOWN IN WALL & HORIZONTALLY BELOW WINDOW TO FIXTURE.
- PROVIDE CIRCUIT SETTER IN NEW & EXISTING HWC LINES & BALANCE TO 3 GPM. RE-BALANCE (E) DOMESTIC CIRCULATOR PUMP TO PROVIDE 6 GPM OF FLOW UPON ACTIVATION.

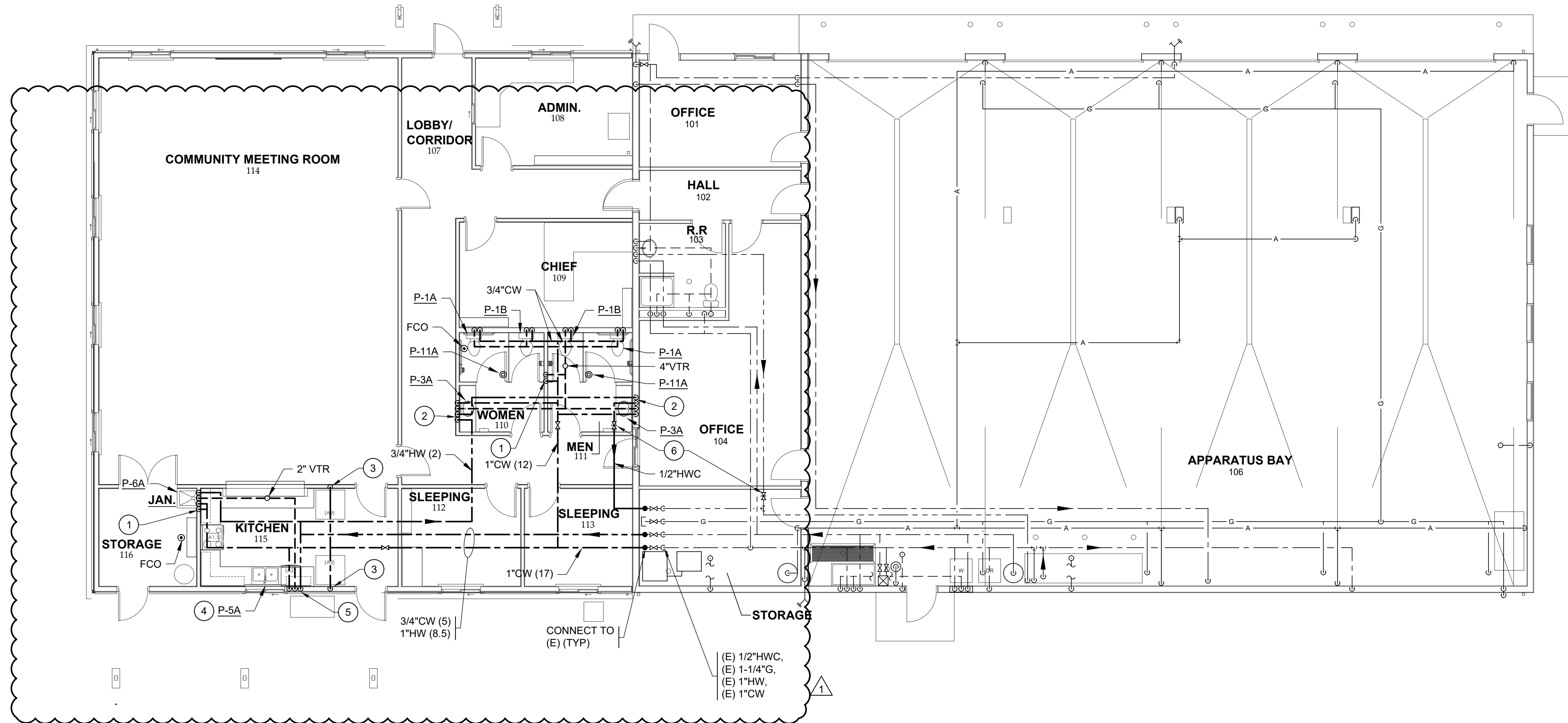

1 FLOOR PLAN - PLUMBING

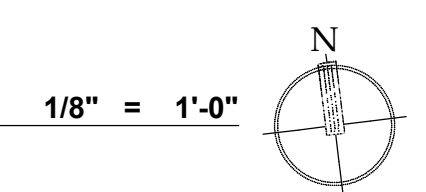

1/8" = 1'-0"

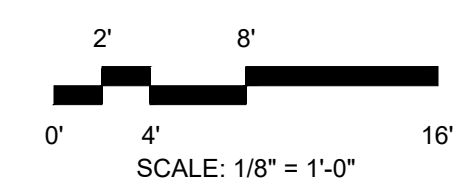

SCALE: 1/8" = 1'-0"

LEWIS COUNTY FIRE DISTRICT #3
MOSSYROCK FIRE STATION
238 MOSSYROCK ROAD E | MOSSYROCK, WA 98564

Project No: 1927
CONSTRUCTION DOCUMENTS
OCTOBER 2, 2020

ADDENDUM 1 10.02.2020

**FLOOR PLAN
- PLUMBING**

M3-1

All material herein constitutes the original and unpublished work of the architect and may not be used, duplicated, or disclosed without the written consent of the architect. Copyright © 2020 by Thomas Architecture Studio. All rights reserved.



525 COLUMBIA ST. | OLYMPIA, WA 98501
360.915.8775 | taso@olympia.com

HULTZ + BHU
engineers inc

1111 Fawcett Ave Suite 100 Tacoma, WA 98402
Phone: (253) 383-3257 Fax: (253) 383-3283
general@hultzbhuh.com Job Number: 20-048



SIGNED

04/15/2020

LEWIS COUNTY FIRE DISTRICT #3
MOSSYROCK FIRE STATION
288 MOSSYROCK ROAD E | MOSSYROCK, WA 98564

Project No: 1927
CONSTRUCTION DOCUMENTS
OCTOBER 2, 2020

ADDENDUM 1 10.02.2020

FLOOR PLAN
- HVAC

M4-1

All material herein constitutes the original and unpublished work of the architect and may not be used, duplicated, or disclosed without the written consent of the architect. Copyright © 2020 by Thomas Architecture Studio. All rights reserved.

KEYED NOTES

- 1 PROVIDE LINED PLENUM SIZED TO MATCH AIR INLET/OUTLET W/ HEIGHT TO ALLOW CONN'S SHOWN.
- 2 EXISTING WALL CAP & LOUVER ARE BELOW NEW ROOF LINE. REMOVE AIR OUTLETS, PATCH WALL & RELOCATE EXISTING WALL CAP AND LOUVER MIN. 12" ABOVE NEW ROOF LINE IN EXISTING WALL.
- 3 ROUTE RAGE HOOD EXHAUST UP THRU ROOF. TERMINATE IN GOOSENECK W/ BUGSCREEN
- 4 REFER TO MANUFACTURER INSTALLATION RECOMMENDATIONS FOR REFRIGERANT PIPE SIZING AND ROUTING FOR MULTI-ZONE UNIT.

GENERAL NOTES:

1. SEE GENERAL NOTES SHEET M1-0.
2. ○ REPRESENTS VENTILATION GRILLES "VG"; SIZE GRILLE TO MATCH CONNECTING DUCT SIZE. NUMBER NEXT TO GRILL REPRESENTS AIRFLOW.
3. ALL NEW SUPPLY AIR DUCTWORK AT NEW HEAT PUMP UNITS TO BE 1" LINED FROM UNIT CONNECTION TO 5 FEET MINIMUM FROM UNIT.
4. SEE ARCHITECTURAL DRAWINGS FOR CEILING TYPES.
5. HVAC EQUIPMENT TO HAVE 3/4" C. ROUTE ON WARM SIDE OF INSULATION TO NEAREST SERVICE SINK OR FUNNEL DRAIN OR DRAIN AT FIXTURE TAILPIECE.
6. PROVIDE P-TRAP AT EQUIPMENT CONDENSATE CONNECTIONS WITH CLEANOUTS, AND CLEANOUTS EVERY 30 FEET IN CONDENSATE PIPING.
7. CONNECT THERMOSTATS TO UNITS THAT SERVE THE SPACE THE THERMOSTAT IS LOCATED IN.
8. COORDINATE LOCATION OF OA INTAKES WITH PLUMBER SO THAT VENTS ARE LOCATED A MINIMUM OF 15 FEET AWAY FROM AIR INTAKES.
9. LOCATE EXHAUST OUTLETS A MINIMUM OF 15 AWAY FROM AIR INTAKES.
10. FOR SUSPENDED EQUIPMENT INSTALLATION SEE DETAIL 3 ON SHEET M4-2.
11. PROVIDE CONDENSATE OVERFLOW SWITCHES FOR ALL CONDENSATE GENERATING EQUIPMENT.
12. INSULATION IS @ CEILING LEVEL, DUCTS WILL BE ROUTED ABOVE INSULATION IN UNCONDITIONED ATTIC SPACE.
13. INSULATE ALL CASSETTE HEAT PUMPS & THEIR COMPONENTS WHICH ARE LOCATED IN THE ATTIC AREA WITH MINIMUM 1" INSULATION HAVING MINIMUM R-VALUE OF R-3 OR MORE AS RECOMMENDED BY EQUIPMENT MFR. INSTALL SYSTEM PER MFR RECOMMENDATIONS TO MAINTAIN ATTIC/ CEILING INSULATION LEVELS.
14. WHERE BALANCING DAMPERS ARE NOT READILY ACCESSIBLE, PROVIDE CABLE DRIVEN DAMPERS & COORDINATE LOCATION OF REMOTE DAMPER OPERATOR W/ OWNER.
15. PROVIDE ALL CONDENSATE GENERATING EQUIPMENT W/ CONDENSATE PUMPS LOCATED IN SHEET METAL DRAIN PAN.
16. SEE DRAWINGS M4-2 FOR REFRIGERANT PIPE SIZING FROM INDOOR TO OUTDOOR MULTI-ZONE UNITS. SUBMIT DRAWINGS OF FINAL REFRIGERATION ARRANGEMENT; SEE SPECIFICATIONS OF FULL REQUIREMENTS.

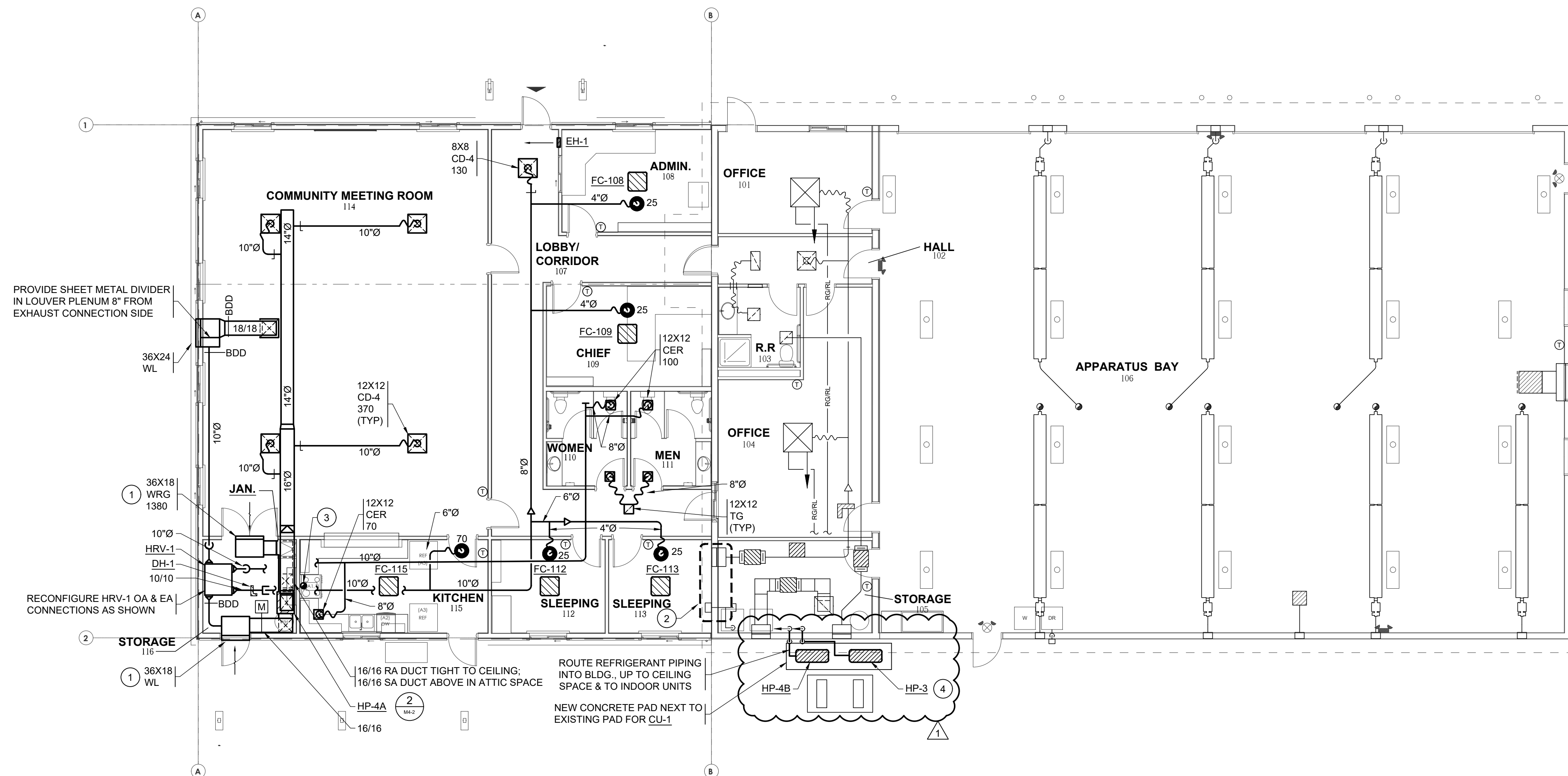

1 FLOOR PLAN - HVAC

1/8" = 1'-0"

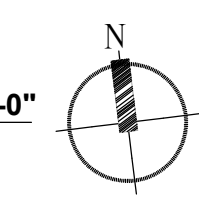
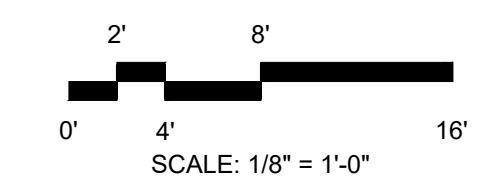

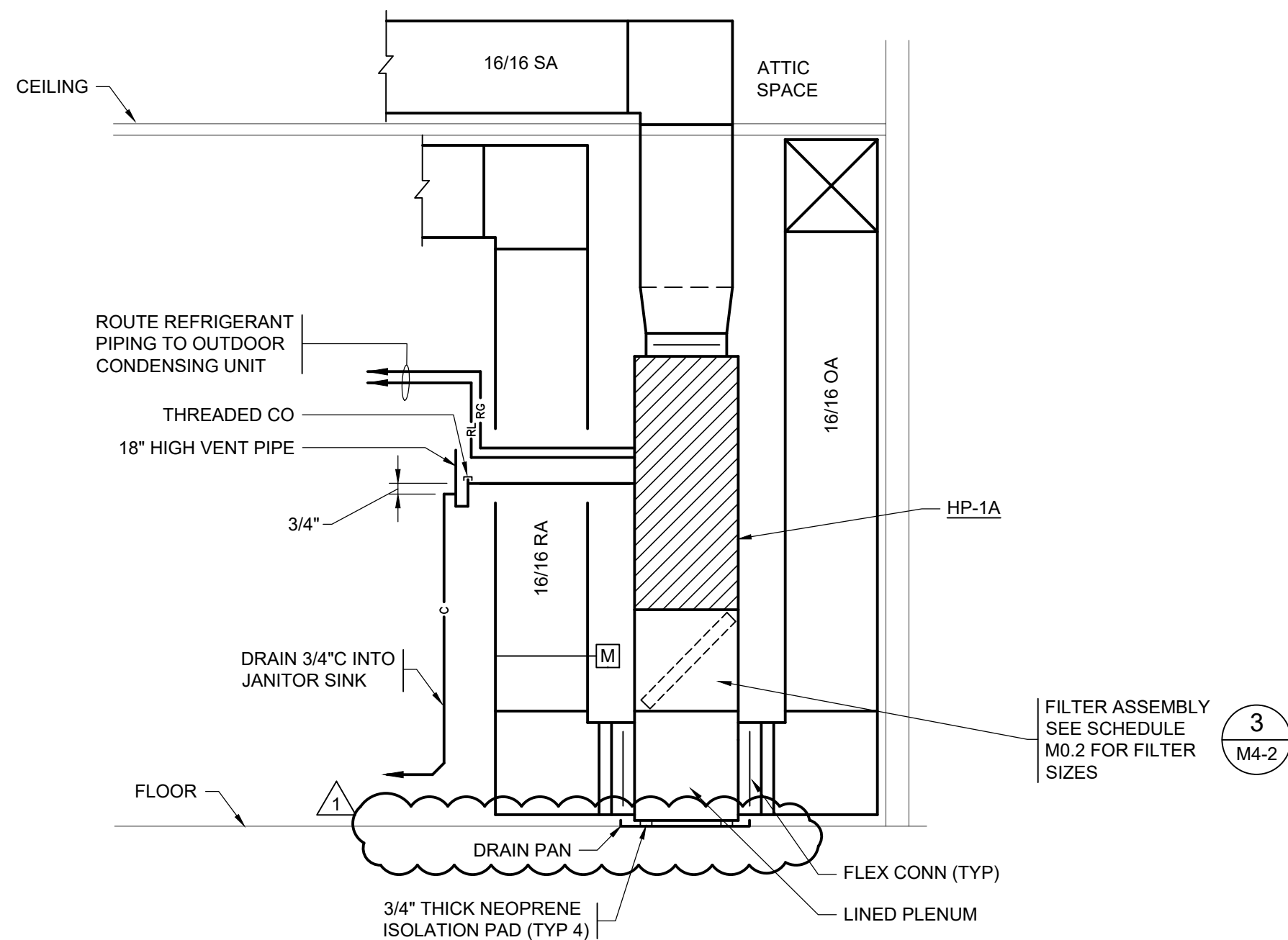

NOTE: PROVIDE HP W/ HIGH LIMIT CONDENSATE SWITCH TO STOP UNIT UPON HIGH CONDENSATE LEVEL.

HP-1A DETAIL

1/2" = 1'-0"

2
M4-2

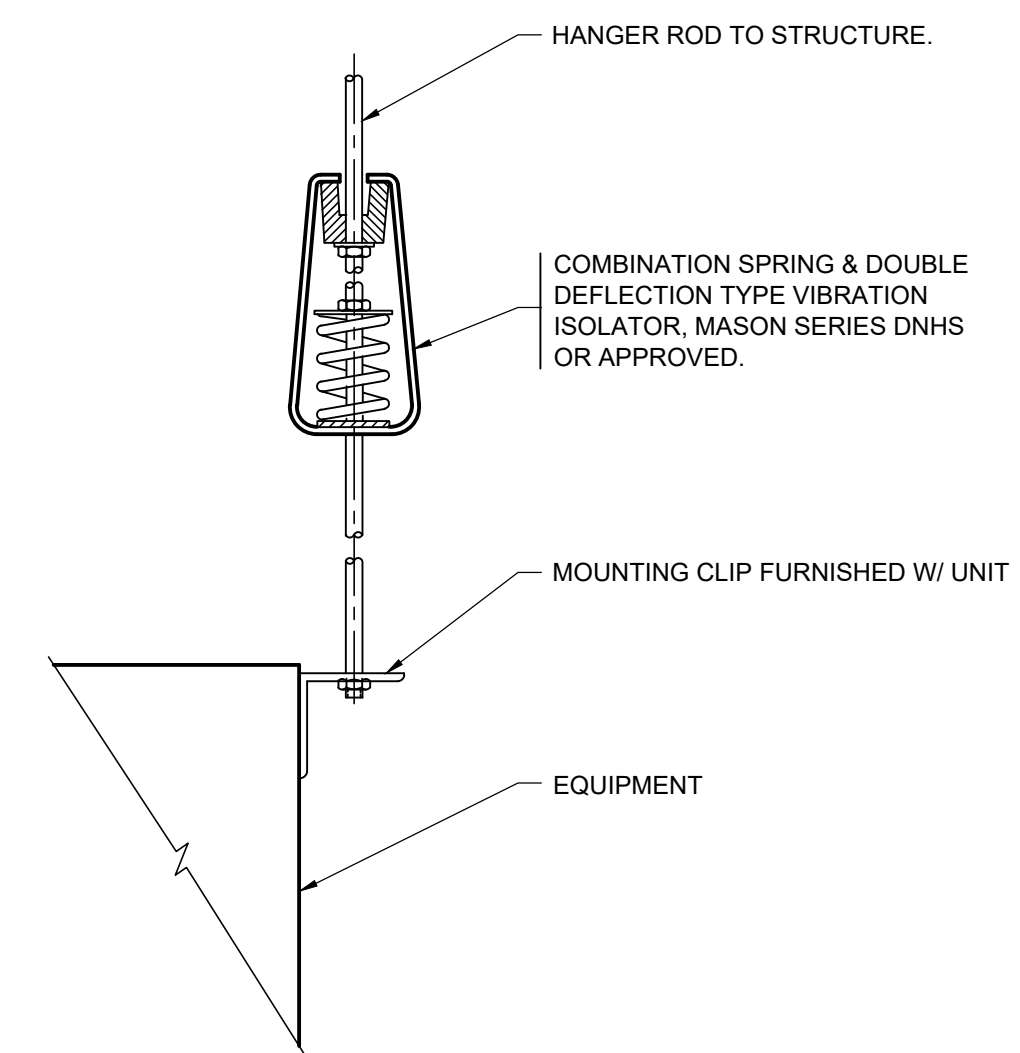

- NOTES:
1. PROVIDE AT SF-1 & EF-1.
 2. VIBRATION ISOLATORS SHALL BE SELECTED FOR 1" DEFLECTION.
 3. MOUNT SPRING ISOLATOR AS CLOSE TO EQUIPMENT AS POSSIBLE.

SUSPENDED EQUIP. SUPPORT

NTS

1
M4-2

DIAGRAM SYMBOL	LEGEND DESCRIPTION
---	POWER WIRE
---	CONTROL WIRE
---	REF. PIPE

PIPING AND CONTROLS SYMBOL	BRANCH PIPE W/VEIL NAME
---	1/4" - 1/2" - 3/4"
---	3/8" - 1/2"
---	1/4" - 1/2"
---	PAR-LINEMED-X

Additional refrigerant charge is needed depending on the size and length of extended piping. Please refer the amount of pre-charge and the formula of calculation which is mentioned on the data book.
 1.25mm(16 AWG) : 1.25mm(16 AWG) or more. 0.75mm(20 AWG) : between 0.5mm(24 AWG) and 0.75mm(20 AWG).

NOTE:
 THIS DIAGRAM IS PROVIDED TO SHOW PRELIMINARY REFRIGERANT PIPE SIZES & UNITS FOR THE BASIS OF DESIGN MFR. IT DOES NOT SHOW ALL REQ'D CONTROL DEVICES NOR CONNECTIONS, NOR A DESIGN FOR OTHER MFR'S. SUPPLIER SHALL PROVIDE A SHOP DRAWING SHOWING ALL PROPOSED PIPE SIZING, CONTROLS & WIRING.

CITY MULTI SYSTEM SCHEMATIC DWG.

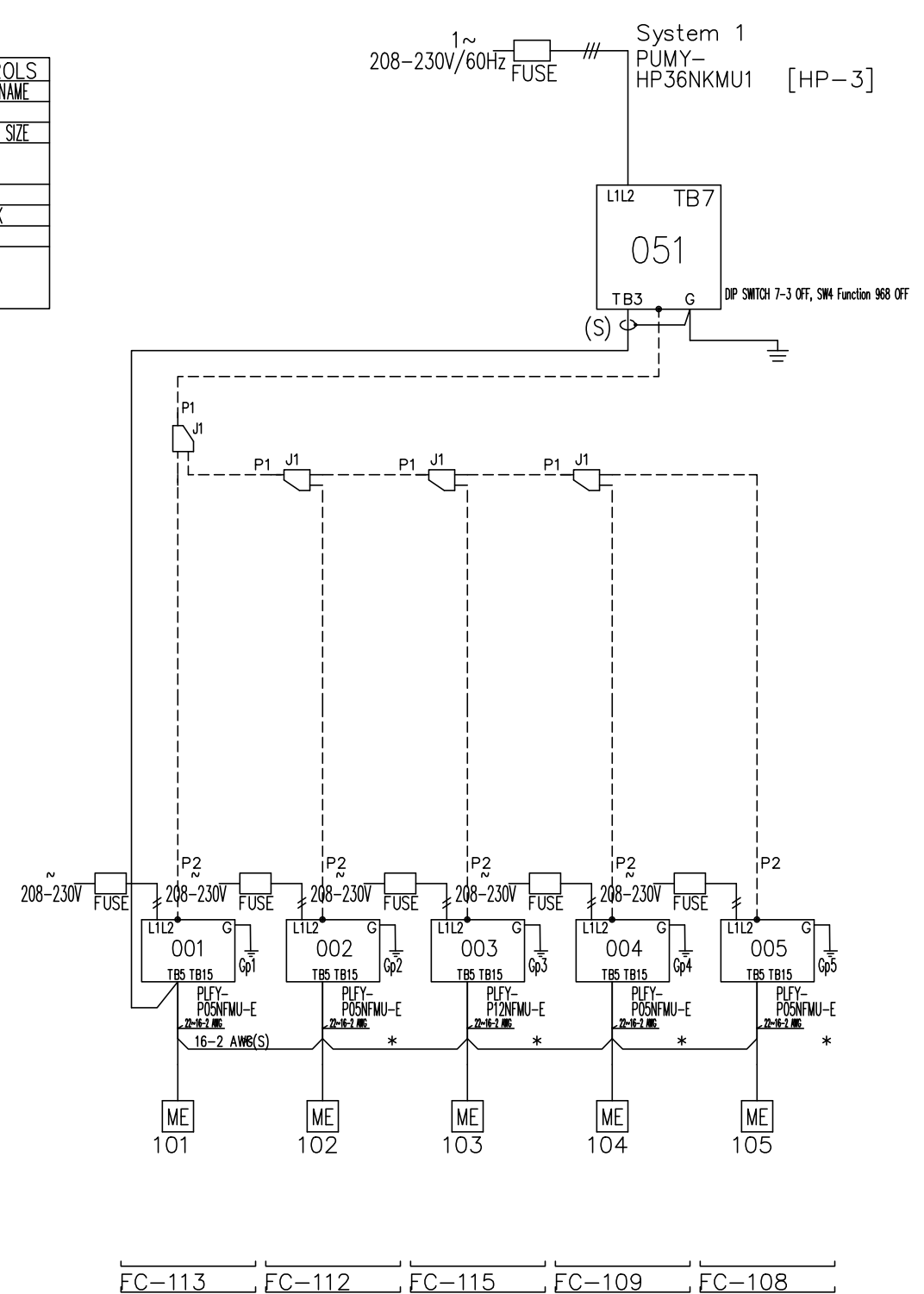

REFRIGERANT PIPING DIAGRAM

NTS

1
M4.4

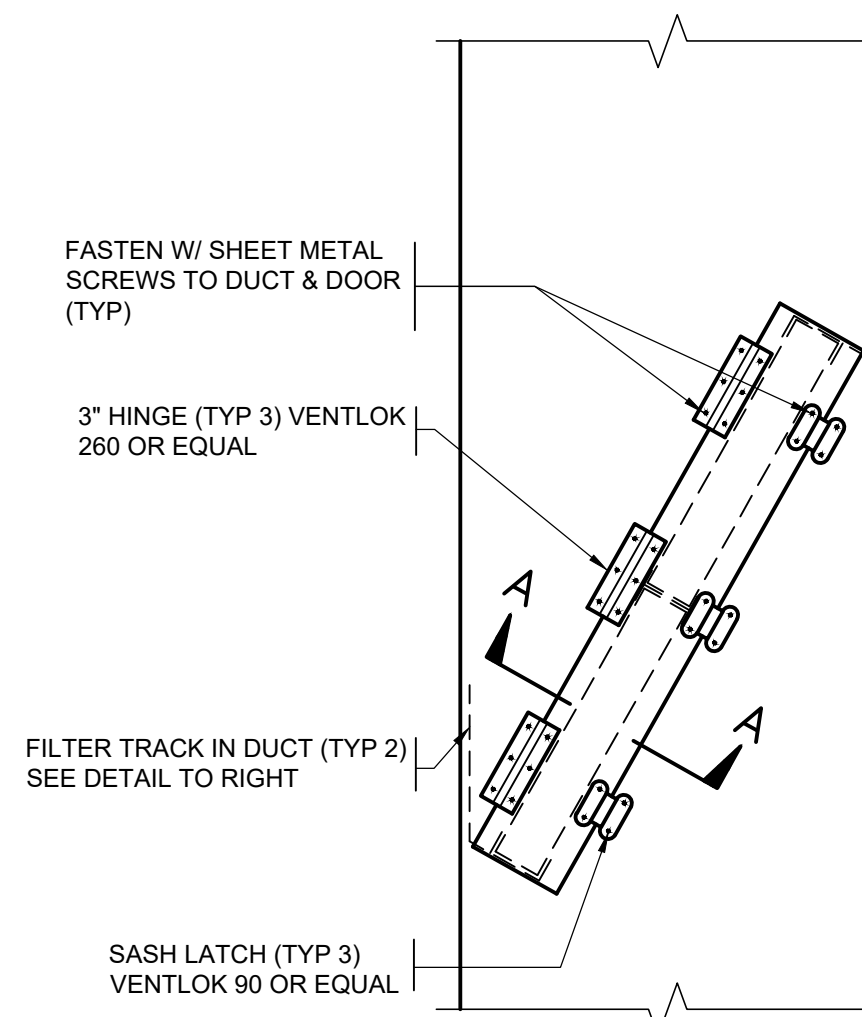

NOTE: SEE EQUIPMENT SCHEDULE FOR MINIMUM REQ'D FILTER SIZES.

FILTER ASSY DETAIL

NTS

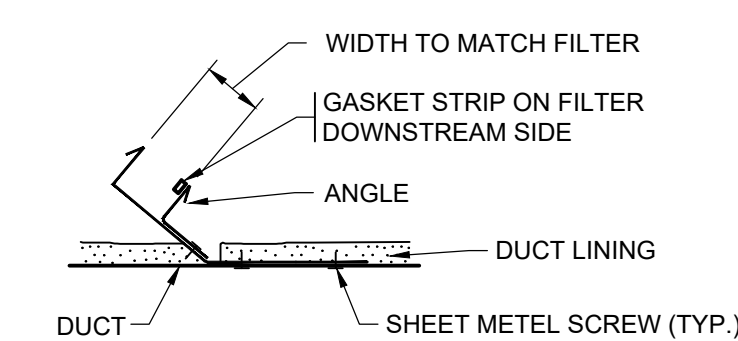

FILTER TRACK

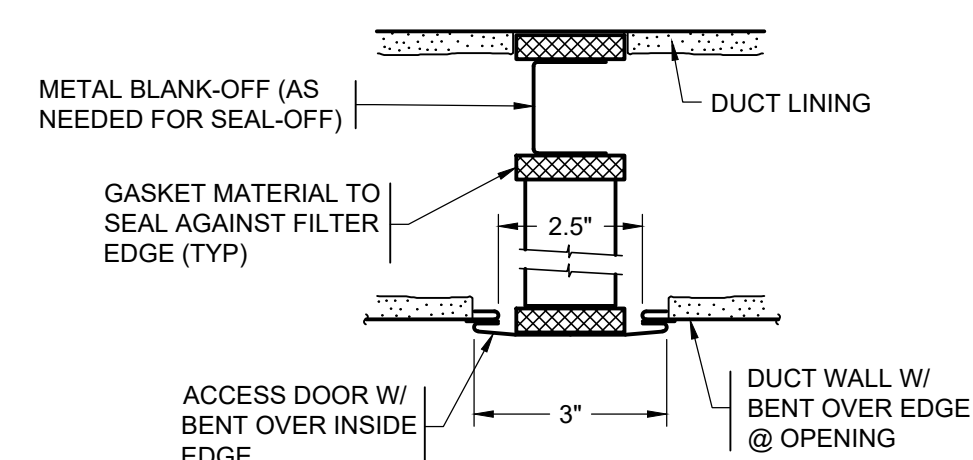

SECTION A - A



525 COLUMBIA ST. | OLYMPIA, WA 98501
 360.915.8775 | tasolympiag.com



1111 Fawcett Ave Suite 100 Tacoma, WA 98402
 Phone: (253) 383-3257 Fax: (253) 383-3283
 general@hultzbhuc.com Job Number: 20-048

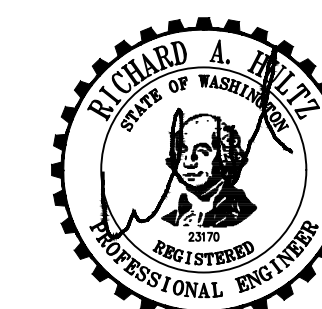

SIGNED

04/15/2020

LEWIS COUNTY FIRE DISTRICT #3
 MOSSYROCK FIRE STATION
 238 MOSSYROCK ROAD E | MOSSYROCK, WA 98564

Project No: 1927
 CONSTRUCTION DOCUMENTS
 OCTOBER 2, 2020

ADDENDUM 1 10.02.2020

HVAC DETAILS

M4-2

All material herein constitutes the original and unpublished work of the architect and may not be used, duplicated, or disclosed without the written consent of the architect. Copyright © 2020 by Thomas Architecture Studio. All rights reserved.

ABBREVIATIONS

(SOME ABBREVIATIONS MAY NOT BE USED ON DRAWINGS)

ABBREVIATION	DESCRIPTION	ABBREVIATION	DESCRIPTION
A or AMP	AMPERES	MH	MANHOLE
AC	ALTERNATING CURRENT	MIN	MINIMUM
A/C	AIR CONDITIONING	MLO	MAIN LUGS ONLY
AIC	AMPERE INTERRUPTING CAPACITY	MOP, MOCP	MAXIMUM OVERCURRENT PROTECTION
AL	ALUMINUM	MTD	MOUNTED
ARCH	ARCHITECTURAL	MTG	MOUNTING
ATC	AUTOMATIC TEMPERATURE CONTROL	NC	NORMALLY CLOSED
ATS	AUTOMATIC TRANSFER SWITCH	N, NEUT	NEUTRAL
AWG	AMERICAN WIRE GAUGE	NIC	NOT IN CONTRACT
BIL	BASIC IMPULSE LEVEL	NO	NORMALLY OPEN
BKR	BREAKER	NTS	NOT TO SCALE
BLDG	BUILDING	OC	ON CENTER
C	CONDUIT	OD	OUTSIDE DIAMETER
C.O.	CONDUIT ONLY	OH	OVERHEAD
°C	DEGREES CELSIUS	PA	PUBLIC ADDRESS
CB	CIRCUIT BREAKER	PB	PULLBOX
CCTV	CLOSED CIRCUIT TELEVISION	PF	POWER FACTOR
CFM	CUBIC FEET PER MINUTE	Ø or PH	PHASE
CKT	CIRCUIT	PNL	PANEL
CL	CENTER LINE	PR	PAIR
CLG	CEILING	PRI	PRIMARY
CONC	CONCRETE	PT	POTENTIAL TRANSFORMER
CT	CURRENT TRANSFORMER	PVC	POLYVINYL CHLORIDE
CU	COPPER	RECPT	RECEPTACLE
CW	COLD WATER	REQ	REQUIRED
BD	DECIBELS	RF	RADIO FREQUENCY
DC	DIRECT CURRENT	RM	ROOM
DIA	DIAMETER	RMS	ROOT MEAN SQUARE
DIV	DIVISION	SEC	SECONDARY
DPDT	DOUBLE POLE, DOUBLE THROW	SHT	SHEET
DPST	DOUBLE POLE, SINGLE THROW	SMR	SURFACE METAL RACEWAY
DWG	DRAWING	SN	SOLID NEUTRAL
EGC	EQUIPMENT GROUND CONDUCTOR	SP	SINGLE POLE
ELEC	ELECTRIC	SPD	SURGE PROTECTIVE DEVICE
EMT	ELECTRICAL METALLIC TUBING	SPDT	SINGLE POLE, DOUBLE THROW
EXST, (E)	EXISTING	SPST	SINGLE POLE, SINGLE THROW
°F	DEGREES FAHRENHEIT	SS	STAINLESS STEEL
FA	FIRE ALARM	STD	STANDARD
FC	FOOTCANDLE	SW	SWITCH
FLA	FULL LOAD AMPS	SWBD	SWITCHBOARD
FLEX	FLEXIBLE CONDUIT	TEL	TELEPHONE
GALV	GALVANIZED	TV	TELEVISION
GFCI	GROUND FAULT CIRCUIT INTERRUPTER	TTB	TELECOMMUNICATIONS TERMINAL BOARD
GND	GROUND	TYP	TYPICAL
H-O-A	HAND - OFF - AUTO	UL	UNDERWRITERS LABORATORY
HP	HORSEPOWER	UF	UNDERFLOOR
HPF	HIGH POWER FACTOR	UG	UNDERGROUND
H & V	HEATING AND VENTILATION	V	VOLTS
HVAC	HEATING, VENTILATION & AIR CONDITIONING	VA	VOLT AMPERES
HZ	HERTZ	VAC	VOLTS ALTERNATING CURRENT
IDF	INTERMEDIATE DISTRIBUTION FRAME	VAR	REACTIVE VOLT AMPERES
J-BOX	JUNCTION BOX	VAV	VARIABLE AIR VOLUME
KV	KILOVOLTS	VD	VOLTAGE DROP
KVA	KILOVOLT AMPERES	VDC	VOLTS DIRECT CURRENT
KVAR	REACTIVE KILOVOLT AMPERES	VFD	VARIABLE FREQUENCY DRIVE
KW	KILOWATTS	VT	VAPORTIGHT
KWH	KILOWATT HOURS	W	WATTS
LT	LIGHT	WP	WEATHERPROOF
LTG	LIGHTING	/W	WITH
MAX	MAXIMUM	W/O	WITHOUT
MCA	MINIMUM CIRCUIT AMPS	XFER	TRANSFER
MCB	MAIN CIRCUIT BREAKER	XFMR	TRANSFORMER
MCC	MOTOR CONTROL CENTER	XLP	CROSS-LINKED POLYETHYLENE
MCM, KCM	THOUSAND CIRCULAR MILS	XP	EXPLOSION PROOF
MDF	MAIN DISTRIBUTION FRAME	Z	IMPEDANCE
MECH	MECHANICAL		

ELECTRICAL LEGEND

(SOME SYMBOLS MAY NOT BE USED ON DRAWINGS)

SYMBOL	DESCRIPTION	SYMBOL	DESCRIPTION
	SCHEDULED EQUIPMENT CONNECTION (INCLUDE ALL WIRING, DISCONNECTING MEANS, CONTROL AND OTHER REQUIREMENTS SCHEDULED)		DUPLEX RECEPTACLE (NEMA 5-20R) SUBSCRIPT: IG ISOLATED GROUND WC WATER COOLER REF REFRIGERATOR COP COPIER HWD HOT WATER DISPENSER MWO MICROWAVE OVEN P PEDESTAL WP WEATHERPROOF C CEILING DW DISHWASHER IWB INTERACTIVE WHITE BOARD TV VIDEO DISPLAY OUTLET. REFER TO ARCHITECTURAL DETAILS FOR MOUNTING HEIGHT
	BUBBLE NOTE TAG SYMBOL: # - IDENTIFYING NUMBER		GFCI DUPLEX RECEPTACLE (NEMA 5-20R) SUBSCRIPT: REF REFRIGERATOR DW DISHWASHER WD WASTE DISPOSER MWO MICROWAVE OVEN
200-4-G	FEEDER CALLOUT X-Y-Z. SEE SCHEDULE.		ASTERISK INDICATES COUNTER HEIGHT OUTLET (DUPLEX RECEPTACLE SHOWN)
200/150-3P	DEVICE SIZE / FUSE OR TRIP RATING - No. OF POLES		RANGE RECEPTACLE (NEMA 14-50R)
	SURFACE FIXTURE - ROUND		OUTLET IN FLOOR BOX (DUPLEX RECEPTACLE SHOWN)
	SURFACE FIXTURE - WALL		TV WALL OUTLET WITH F CONNECTOR TAP
	EMERGENCY FIXTURE - TWIN HEAD		DATA (COMPUTER) OUTLET WITH JACK
	COMBINATION EXIT SIGN AND TWIN HEAD EMERGENCY LIGHTING UNIT		WIRELESS ACCESS POINT
	SURFACE MOUNT FIXTURE WITH EMERGENCY LIGHTING UNIT		CIRCUIT BREAKER
	WALL SURFACE MOUNT FIXTURE WITH EMERGENCY LIGHTING UNIT		DELTA CONNECTION
	SINGLE POLE TOGGLE SWITCH		UTILITY COMPANY METER
	DIGITAL SWITCH STATION		GENERATOR
	SWITCH SUBSCRIPTS: 2 DOUBLE POLE 3 THREE WAY 4 FOUR WAY D DIMMER EP EXPLOSION PROOF K KEY OPERATED LV LOW VOLTAGE LVM LOW VOLTAGE MASTER M MANUAL MOTOR STARTER W/OVERLOADS MC MOMENTARY CONTACT P SWITCH W/PILOT LIGHT T TIMER WP WEATHERPROOF a, b, c MULTIGANG SWITCH STATION		CURRENT TRANSFORMER (CT)
	OCCUPANCY SENSOR - CEILING MOUNT		GROUND ELECTRODE SYSTEM
	OCCUPANCY SENSOR - WALL SWITCH		PANELBOARD - SURFACE
	DIGITAL PLUG CONTROLLER		CEILING MOUNTED SMOKE DETECTOR FIRST ALERT ULTIMATE PROTECTION MODEL #SA3210 OR SIMILAR
	DIGITAL ROOM CONTROLLER		CEILING MOUNTED COMBINATION SMOKE AND CARBON MONOXIDE DETECTOR. FIRST ALERT, MODEL # SC07 OR SIMILAR
	DAYLIGHT SENSOR		REMOTE ANNUNCIATOR
	JUNCTION BOX		MANUAL STATION
	RECEPTACLE CONTROLLED BY OCCUPANCY SENSOR OR TIME SWITCH (1/2 OF OUTLET IS CONTROLLED WHERE SPLIT WIRED IS INDICATED)		HORN [SPEAKER] WITH VISUAL SIGNAL (STROBE)
			VISUAL SIGNAL (STROBE)

NOTE:
STANDARD LINE WEIGHT INDICATES EXISTING CONDITIONS. _____
HEAVY LINE WEIGHT INDICATES NEW WORK. _____

OUTLET MOUNTING HEIGHTS

(MEASURE TO CENTER OF BOX, UNLESS OTHERWISE INDICATED)

COUNTER HEIGHT (*)	+3 INCHES ABOVE SPLASH	FIRE ALARM	
CASEWORK OUTLETS	AS DIRECTED	MANUAL STATIONS	48 INCHES TO TOP
SWITCHES & DIMMERS	48 INCHES	SIGNALING DEVICES	80 INCHES TO BOTTOM
RECEPTACLES	18 INCHES	REMOTE ALARM LIGHTS	80 INCHES TO BOTTOM
THERMOSTATS	48 INCHES	REMOTE ANNUNCIATOR	60 INCHES TO BOTTOM
OCCUPANCY SENSORS	12 FEET MAXIMUM	GRAPHIC PLAQUES	60 INCHES TO BOTTOM
VOICE (TELEPHONE)	18 INCHES		
DATA (COMPUTER)	18 INCHES	SECURITY	
WALL PHONE	48 INCHES	KEY PAD	54 INCHES TO TOP
TV (TELEVISION)	18 INCHES	CARD READER	48 INCHES
TV WALL MOUNTED	CENTER OF TV BRACKET	CCTV	WITHIN 6 INCHES OF CAMERA MOUNT
SPEAKERS	90 INCHES	CCTV POLE MOUNTED	20 FEET
CLOCKS	90 INCHES		
CLOCK/SPEAKER	90 INCHES		

GENERAL ELECTRICAL NOTES:

- SEE ARCHITECTURAL PLANS FOR LOCATION OF FIRE RATED CONSTRUCTION.
- BRANCH CIRCUIT NOTES:
 - VERIFY BRANCH CIRCUIT WIRE COUNT BEFORE PULLING CONDUCTORS. PROVIDE REQUIRED CONDUCTORS TO EACH OUTLET AND DEVICE FOR PHASE, NEUTRAL AND EQUIPMENT GROUND BASED ON CIRCUIT DESIGNATIONS SHOWN AND AS OTHERWISE INDICATED ON PLANS OR NOTE BELOW.
 - FOR SWITCHED OUTLETS, PROVIDE ADDITIONAL CONDUCTOR COUNT REQUIRED FOR SWITCH LEGS TO ACCOMMODATE SWITCH CONTROL INDICATED. MAINTAIN UNSWITCHED LEG IN LIGHTING BRANCH CIRCUITS TO EXIT, EMERGENCY, AND NIGHT LIGHTING SHOWN.
 - MINIMUM BRANCH CIRCUIT CONDUCTOR SIZE FOR OUTDOOR AND EXTERIOR BUILDING LIGHTING SHALL BE #10 AWG.
 - PROVIDE SEPARATE NEUTRAL CONDUCTOR FOR BRANCH CIRCUITS SERVING RECEPTACLE OUTLETS UNLESS OTHERWISE INDICATED.
 - PROVIDE MANUFACTURER APPROVED PIN INSERT STYLE HANDLE TIES BETWEEN SINGLE POLE CIRCUIT BREAKERS SERVING BRANCH CIRCUITS SHARING A COMMON NEUTRAL.
- MINIMUM CONDUIT SIZE FOR HOMERUNS AND FOR CONDUIT INSTALLED BELOW GRADE OUTDOORS SHALL BE 3/4 INCH.
- REFER TO REFLECTED CEILING PLANS, INTERIOR ELEVATIONS, ROOM SECTIONS, AND DETAILS SHOWN ON ARCHITECTURAL CONTRACT DOCUMENTS PRIOR TO ROUGH-IN. REPORT CONFLICTS TO ARCHITECT/ENGINEER FOR RESOLUTION.
- REFER TO ARCHITECTURAL ELEVATIONS FOR LOCATION AND MOUNTING HEIGHT OF WIRING DEVICES. REPORT CONFLICTS TO ARCHITECT/ENGINEER FOR RESOLUTION.
- VERIFY EXACT LOCATION OF FLOOR BOXES AND OUTLETS LOCATED IN KNEE SPACES AND CASEWORK. OBTAIN ARCHITECT APPROVAL PRIOR TO ROUGH-IN.
- VERIFY BACK BOX REQUIREMENTS OF EQUIPMENT FURNISHED UNDER OTHER THAN DIVISION 16 SECTIONS AND EQUIPMENT FURNISHED BY OWNER.
- SEE MECHANICAL PLANS FOR QUANTITY AND LOCATION OF SMOKE DAMPERS. PROVIDE 120 VOLT CONNECTION TO EACH DAMPER.



T H O M A S
architecture studios
525 COLUMBIA ST. | OLYMPIA, WA 98501
360.915.8775 | tsoolympia.com



1111 Fawcett Ave Suite 100 Tacoma, WA 98402
Phone: (253) 383-3257 Fax: (253) 383-3283
general@hultzbhu.com Job Number: 20-048



SIGNED
10-02-2020

LEWIS COUNTY FIRE DISTRICT #3
MOSSYROCK FIRE STATION
288 MOSSYROCK ROAD E | MOSSYROCK, WA 98564

Project No: 1927
CONSTRUCTION DOCUMENTS
OCTOBER 2, 2020

REVISION: DATE
1 - REVISION 1 6/11/2020
2 - REVISION 2 10/02/2020

LEGEND, NOTES & ABBREVIATIONS

E-001

All material herein constitutes the original and unpublished work of the architect and may not be used, duplicated, or disclosed without the written consent of the architect. Copyright © 2020 by Thomas Architecture Studio. All rights reserved.

NEW

Panel 'C'											
120/240V, 1Ph, 3W.; 400A Bus with Main Lug Only Surface Mounted Panelboard with a minimum fault current rating of 22,000 AIC											
Ckt. No.	Description / Location	Load (VA)	Type	C.B. A/Pole	Note	Ph.	Note	C.B. A/Pole	Note	Ph.	Ckt. No.
1	LTG - MEETING, STOR., KITCHEN	882	L	20/1		A					2
3	LTG - ADMIN, CHIEF, HALL, R.R, SLEE.	756	L	20/1		B					4
5	REC - KITCHEN REF	650	K	20/1		A					6
7	REC - KITCHEN DW	1,500	K	20/1		B					8
9	REC - KITCHEN DISP	750	K	20/1		A					10
11	REC - KICHEN, STOR	900	R	20/1		B					12
13	REC - KITCHEN REF	650	K	20/1		A		20/1	1,000	H	14
15	REC - MEETING RM	1,080	R	20/1		B		20/2	1,250	H	16
17	REC - MEETING RM	1,080	R	20/1		A					18
19	REC - MEETING RM TV	750	G	20/1		B		15/2	288	M	20
21	REC - MEETING RM	360	R	20/1		A					22
23	REC - ADMIN	720	R	20/1		B		15/2	132	M	24
25	REC - ADMIN COPY	1,200	R	20/1		A					26
27	REC - CHIEF	900	R	20/1		B		30/2	1,596	M	28
29	REC - HALL R.R.	900	R	20/1		1	A				30
31	REC - SLEEPING	720	R	20/1		1	B				32
33	REC - SLEEPING	720	R	20/1		1	A				34
35	REC - OUTSIDE	540	R	20/1		B		30/2	1,032	M	36
37	REC - KITCHEN RANGE	4,000	K	40/2		A					38
39		4,000	K			B					40
41						A					42

Connected Load:	Ph. A	16,490 VA	137 Amps
Connected Load:	Ph. B	16,164 VA	135 Amps
Panel Connected Load:		32.7 KVA	150.1 Amps
Total Demand Load:		30.4 KVA	126.7 Amps

Notes:

1. PROVIDE ARC-FAULT CIRCUIT BREAKER.

Load Description	Connected Loads	Subded Loads (S)	Total Loads	Demand Factor	Demand Load
G General (Non-Continuous)	0.75	0.00	0.75	100%	0.75 (KVA Typical)
L Lighting	1.64	0.00	1.64	125%	2.05
R Receptacles - to 10 KVA over 10 KVA	9.12	0.00	9.12	100%	9.12
K Kitchen	11.55	0.00	11.55	50%	0.00
H Heating	3.50	0.00	3.50	70%	8.09
M Motors	2.90	0.00	2.90	100%	3.50
LM Largest Motor	3.19	0.00	3.19	125%	3.99
WH Water Heater	0.00	0.00	0.00	125%	0.00
C Continuous General Load	0.00	0.00	0.00	125%	0.00
Total:					30.40 KVA

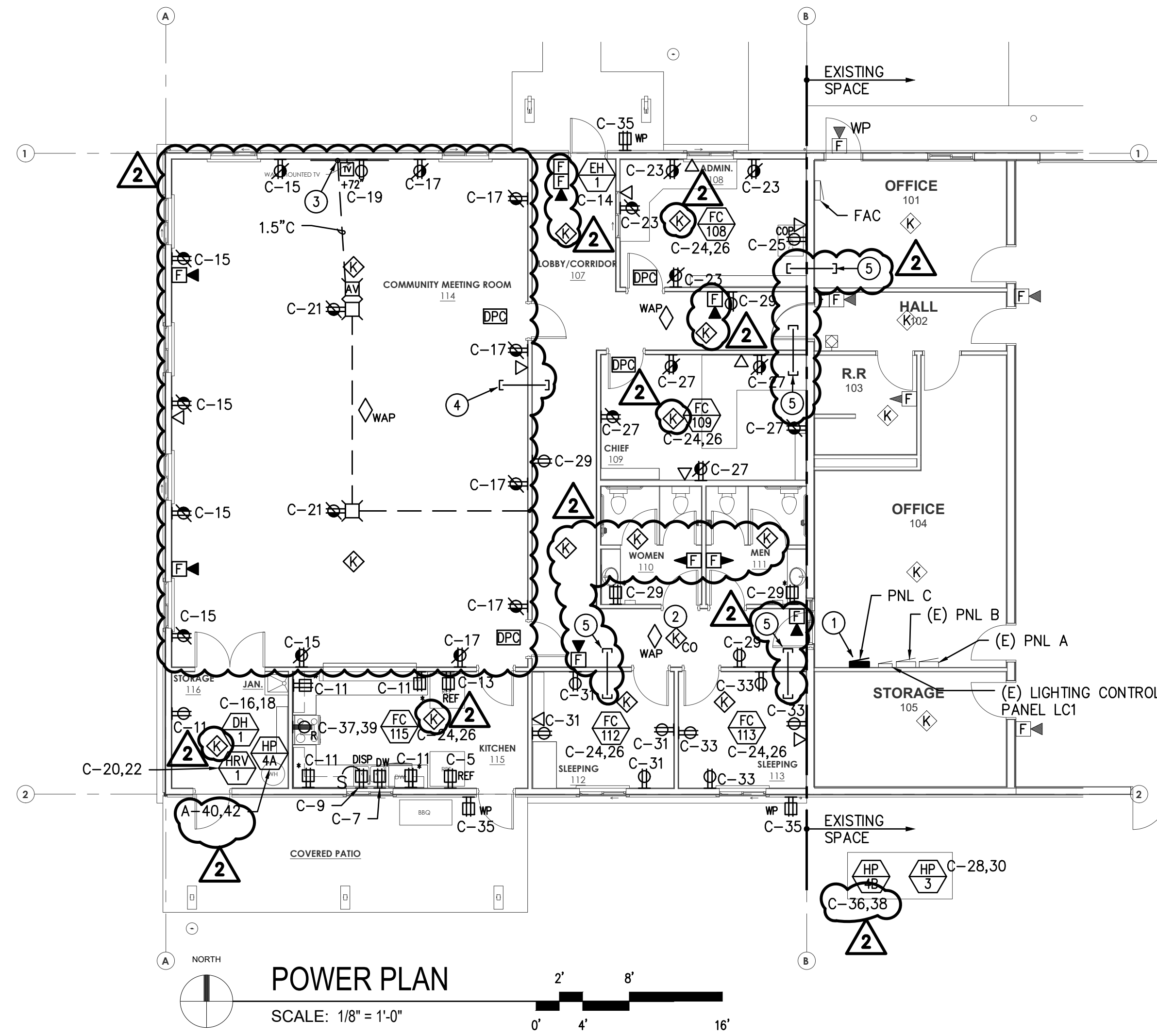

CONSTRUCTION NOTES:

- ARC FAULT CIRCUIT PROTECTION TO BE IN ALL BEDROOMS, HALLWAYS, AND BATHROOMS.

PLAN NOTES:

- PROVIDE NEW PANEL. SEE ONE-LINE DIAGRAM FOR MORE INFORMATION.
- CENTER COMBINATION SMOKE/CARBON MONOXIDE DETECTOR BETWEEN DOORS.
- TERMINATE CONDUIT IN CEILING SPACE ABOVE.
- 2" CONDUIT SLEEVE IN CEILING SPACE ABOVE.
- 1.25" CONDUIT SLEEVE IN CEILING SPACE ABOVE.



THOMAS architecture studios
525 COLUMBIA ST. | OLYMPIA, WA 98501
360.915.8775 | tasolympia.com

HULTZ BHU engineers inc

1111 Fawcett Ave Suite 100 Tacoma, WA 98402
Phone: (253) 383-3257 Fax: (253) 383-3283
general@hultzbhu.com Job Number: 20-048



SIGNED 10-02-2020

LEWIS COUNTY FIRE DISTRICT #3
MOSSYROCK FIRE STATION
238 MOSSYROCK ROAD E | MOSSYROCK, WA 98564

MECHANICAL EQUIPMENT CONNECTION SCHEDULE															
NAME	DESCRIPTION	LOCATION	HP	MAXIMUM RATINGS				VOLT/PH	#12 EACH PHASE NEUTRAL, PLUS GROUND	CIRCUIT#	DISCONNECT BY	DESCRIPTION	CONTROLS		REMARKS
				KVA	FLA	MCA	MOCP						STARTER	BY DESCRIPTION	
HP-3	HEAT PUMP	OUTDOOR		3.19	13.3	29.0	40	240 1	3/4"C-2#8 +#10 GND	SEE PNL SCH	•	60A 2P FUSED WP			
HP-4A	SPLIT SYSTEM HEAT PUMP	INDOOR		11.08	46.2	57.7	60	240 1	1"C-2#4 +#10 GND	SEE PNL SCH	•	60A FUSED 2P			
HP-4B	SPLIT SYSTEM HEAT PUMP	OUTDOOR		2.07	8.6	25.0	30	240 1	3/4"C-2#10 +#10 GND	SEE PNL SCH	•	30A 2P FUSED WP			
FC-108	CEILING CASSETTE	ADMIN 108		0.06	0.2	0.3	15	240 1		SEE PNL SCH	•	TOGGLE			
FC-109	CEILING CASSETTE	CHIEF 109		0.06	0.2	0.3	15	240 1		SEE PNL SCH	•	TOGGLE			
FC-112	CEILING CASSETTE	SLEEPING 112		0.06	0.2	0.3	15	240 1		SEE PNL SCH	•	TOGGLE			
FC-113	CEILING CASSETTE	SLEEPING 113		0.06	0.2	0.3	15	240 1		SEE PNL SCH	•	TOGGLE			
FC-115	CEILING CASSETTE	KITCHEN 115		0.07	0.3	0.4	15	240 1		SEE PNL SCH	•	TOGGLE			
HRV-1	DOAS HEAT RECOVERY	JAN		0.28	1.2	2.0	15	240 1		SEE PNL SCH	•	TOGGLE			
DH-1	DUCT HEATER	JAN		2.50	10.4	13.0	20	240 1		SEE PNL SCH	•	TOGGLE			
EH-1	WALL HEATER	HALL		1.00	8.3	10.4	20	120 1		SEE PNL SCH	•	TOGGLE			

EQUIPMENT CONNECTION SCHEDULE NOTES:

- VERIFY VOLTAGE, PHASE, FLA/MCA OF EACH CONNECTION WITH EQUIPMENT SUPPLIER PRIOR TO ROUGH-IN. NOTIFY ARCHITECT/ENGINEER WHEN SCHEDULED SUPPLY WILL NOT MEET NEC REQUIREMENTS.
- OUTLETS, DISCONNECTS, CONTROLLERS, AND EQUIPMENT CONNECTIONS FOR ROOF TOP AND OTHER OUTDOOR EQUIPMENT SHALL BE WEATHER PROOF.
- LOCATION OF OUTLETS, DISCONNECTS, CONTROL DEVICES, AND EQUIPMENT CONNECTIONS ARE DIAGRAMMATIC AND TO BE LOCATED IN FIELD BY THE CONTRACTOR AS APPROVED BY THE ENGINEER. UNLESS OTHERWISE INDICATED ON PLANS, INSTALL SCHEDULED DISCONNECTS AND CONTROL DEVICES IN SIGHT OF EQUIPMENT. ARRANGE WIRING AND EQUIPMENT TO AVOID INTERFERENCE WITH OTHER WORK AND TO MAXIMIZE ACCESSIBILITY FOR MAINTENANCE AND REPAIRS.
- COORDINATE WITH THE OTHER INSTALLING CONTRACTORS TO ENSURE NEC REQUIRED ACCESS TO DISCONNECTS IS PROVIDED FOR EACH PIECE OF EQUIPMENT.
- PROVIDE SMOKE DUCT DETECTORS IN HEATING AND COOLING SYSTEMS PER INTERNATIONAL MECHANICAL CODE. SEE DIVISION 25 EQUIPMENT SCHEDULES FOR ADDITIONAL UNITS RATED OVER 2000 CFM AND PROVIDE DUCT DETECTOR AS REQUIRED.
- WIRING BETWEEN EQUIPMENT DISCONNECT AND POINT OF CONNECTION SHALL COMPLY WITH NEC BASED ON EQUIPMENT NAMEPLATE RATING EXCEPT MINIMUM BRANCH CIRCUIT RATING SHALL BE 20 AMPERES.
- SIZE OF DISCONNECT SWITCH AND MOTOR STARTER SHALL BE SIZED TO COMPLY WITH NEC REQUIREMENTS. WHERE INDICATED MOTOR CONTROL IS NOT LOCATED IN SIGHT OF MOTOR AS DEFINED BY NEC, PROVIDE ADDITIONAL DISCONNECTING MEANS TO COMPLY WITH NEC 430.102.
- WIRING SIZES ARE BASED ON 60 DEGREE C. FOR AMPACITIES 100 AMPERES AND LESS. FOR FEEDERS LESS THAN 100 FEET IN LENGTH, CONDUCTOR SIZES MAY BE SELECTED BASED ON 75 DEGREE C. WHERE EQUIPMENT INSTALLED IS LABELED FOR 75 DEGREE C. WIRING.
- SCHEDULE LEGEND:
 - = FURNISH AND INSTALL NEW UNDER DIVISION 26
 - = INSTALL UNDER DIVISION 26; FURNISHED WITH EQUIPMENT OR BY OTHERS.
 - X = FURNISH AND INSTALL BY OTHERS (NOT DIVISION 26)
 - * = EXISTING, RELOCATED EQUIPMENT

Project No: 1927
CONSTRUCTION DOCUMENTS
OCTOBER 2, 2020

REVISION: DATE
1 - REVISION 1 6/11/2020
2 - REVISION 2 10/02/2020

POWER PLAN

E-301

All material herein constitutes the original and unpublished work of the architect and may not be used, duplicated, or disclosed without the written consent of the architect. Copyright © 2020 by Thomas Architecture Studio. All rights reserved.



THOMAS
architecture studios

525 COLUMBIA ST. | OLYMPIA, WA 98502
360.915.8775 | tasolympia.com

HULTZ BHU
engineers inc

1111 Fawcett Ave Suite 100 Tacoma, WA 98402
Phone: (253) 383-3257 Fax: (253) 383-3283
general@hultzbhu.com Job Number: 20-048

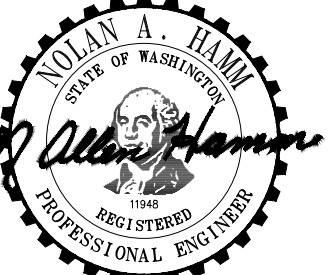

SIGNED
10-02-2020

LEWIS COUNTY FIRE DISTRICT #3
MOSSYROCK FIRE STATION
238 MOSSYROCK ROAD E | MOSSYROCK, WA 98564

EXISTING

ATS		Available Fault:		
No.	Description / Location	Note	Load (VA)	Load Type
1	Panel 'A'		16,239	S
-			14,526	S
2	Panel 'B'		30,722	S
-			28,697	S
Total Connected Load: Ph A		46,961 VA	391 Amps	
Total Connected Load: Ph B		43,223 VA	360 Amps	
Total Connected Load:		90.2 KVA	375.8 Amps	
Total Demand Load:		120.4 KVA	501.6 Amps	

NOTES:
1.
2.
3.
4.
5.

Load Type	Load Description	Connected Loads	Subfd Loads (C)	Total Loads	Demand Factor	Demand Load
G	General (Non-Continuous)	0.00	18.48	18.48	100%	18.48 KVA
L	Lighting	0.00	5.60	5.60	125%	7.00 KVA
R	Receptacles - to 10 KVA over 10 KVA	0.00	15.40	10.00	100%	10.00 KVA
K	Kitchen	0.00	11.55	7.40	50%	3.70 KVA
H	Heating	0.00	13.10	11.55	70%	8.09 KVA
M	Motors	0.00	43.48	13.10	100%	13.10 KVA
LM	Largest Motor	0.00	11.44	43.48	100%	13.10 KVA
WH	Water Heater	0.00	1.80	11.44	125%	14.30 KVA
C	Continuous General Load	0.00	0.00	1.80	125%	2.25 KVA
				0.00	125%	0.00 KVA
Total:						120.38 KVA

EXISTING

Panel 'A'		120/240V, 1Ph, 3W.; 225A Bus with 225A Main Circuit Breaker Surface Mounted Panelboard with a minimum fault current rating of 22,000 AIC					
Ckt. No.	Description / Location	Load (VA)/Type	C.B. A/Pole Note Ph. Note	C.B. A/Pole (VA)/Type	Load (VA)/Type	Description / Location	Ckt. No.
1	SPARE		20/1 A	20/1	1,080 R	RECP - OFFICE 101	2
3	LTG - RM 101 TO 105	897 L	20/1 B	20/1	720 R	RECP - HALL 102, RR 103, OUTSIDE	4
5	LTG - APPARATUS 106	1,176 L	20/1 A	20/1	720 R	RECP - OFFICE 104	6
7	LTG - APPARATUS 106	784 L	20/1 B	20/1	720 R	RECP - OFFICE 104	8
9	LTG - BUILDING EXTERIOR, SITE	563 L	20/1 A	20/1	360 R	RECP - STORAGE 105	10
11	LTG - STORAGE 100 (ALTERNATE NO.1)	540 L	20/1 B	20/1	360 R	RECP - STOR. 105 TTB	12
13	SPARE		20/1 A	20/1	360 R	RECP - STOR. 105 RADIO	14
15	SPARE		20/1 B	20/1	360 R	RECP - STORAGE 105 RADIO/SCANNER	16
17	SPARE		20/1 A	20/1	540 R	RECP - STORAGE 100 (ALTERNATE NO. 1)	18
19	SPARE		20/1 B	20/1		SPARE	20
21	SPARE		20/1 A	20/1		SPARE	22
23	SPARE		20/1 B	20/1		SPARE	24
25	SPARE		20/1 A	20/1		SPARE	26
27	FAC	300 G	20/1 B	20/1	125 M	CP-1	28
29	LIGHTING CONTROL PANEL LC1	100 G	20/1 A	20/1	1,800 WH	WH-1	30
31	SPARE		20/1 B	20/1	1,500 G	RECP - APPARATUS 106 WASHER	32
33	BLOCK HEATER - GENERATOR	1,500 G	20/1 A	30/2	2,500 G	APPARATUS 106 DRYER	34
35	RECP - GENERATOR BATT CHARGER	180 R	20/1 B	-	2,500 G	-	36
37	SPACE		A			SPACE	38
39	SPACE		B	60/2	5,540 M	HP-4A (INDOOR)	40
41	SPACE		A	-	5,540 M	-	42

Connected Load: Ph. A 16,239 VA 135 Amps
Connected Load: Ph. B 14,526 VA 121 Amps
Total Demand Load: 35.0 KVA 145.7 Amps

Accessories:
Notes:
1.
2.
3.
4.
5.

Load Type	Load Description	Connected Loads	Subfd Loads (S)	Total Loads	Demand Factor	Demand Load
G	General (Non-Continuous)	8.40	0.00	8.40	100%	8.40 (KVA Typical)
L	Lighting	3.96	0.00	3.96	125%	4.95
R	Receptacles - to 10 KVA over 10 KVA	5.40	0.00	5.40	100%	5.40
K	Kitchen	0.00	0.00	0.00	50%	0.00
H	Heating	0.00	0.00	0.00	100%	0.00
M	Motors	0.13	0.00	0.13	100%	0.13
LM	Largest Motor	11.08	0.00	11.08	125%	13.85
WH	Water Heater	1.80	0.00	1.80	125%	2.25
C	Continuous General Load	0.00	0.00	0.00	125%	0.00
Total:						34.98 KVA

REVISED

Panel 'B'		120/240V, 1Ph, 3W.; 400A Bus with 400A Main Circuit Breaker Surface Mounted Panelboard with a minimum fault current rating of 22,000 AIC						
Ckt. No.	Description / Location	Load (VA)/Type	C.B. A/Pole Note Ph. Note	C.B. A/Pole (VA)/Type	Load (VA)/Type	Description / Location	Ckt. No.	
1	RECP - APPARATUS BAY CORD REAL	180 R	20/1 A	20/1	720 R	RECP - APPARATUS NORTH	2	
3	RECP - APPARATUS BAY CORD REAL	180 R	20/1 B	20/1	825 G	RECP - APPARATUS EAST & EF-4	4	
5	RECP - APPARATUS BAY CORD REAL	180 R	20/1 A	20/1	540 R	RECP - APPARATUS SOUTH	6	
7	RECP - APPARATUS BAY CORD REAL	180 R	20/1 B	60/2	4,250 G	RECP - APPARATUS, WELDER	8	
9	APPARATUS BAY ROLL-UP DOOR	1,660 M	20/1 A	-	4,250 G	-	10	
11	APPARATUS BAY ROLL-UP DOOR	1,660 M	20/1 B	20/1	1,660 M	EF-1	12	
13	APPARATUS BAY ROLL-UP DOOR	1,660 M	20/1 A	20/2	1,000 H	EH-2	14	
15	APPARATUS BAY ROLL-UP DOOR	1,660 M	20/1 B	20/1	1,000 H	-	16	
17	RH-1, 2, 3	1,800 H	20/1 A	20/1	1,800 H	RH-4, 5, 6	18	
19	DH-1	1,250 H	20/2 B	20/1	890 M	SPARE	20	
21		1,250 H	-	A	20/1	SPARE	22	
23	EH-1	750 H	15/1 B	20/1	SPARE	SPARE	24	
25		750 H	20/1 A	20/2	817 M	HP-1	26	
27	HP-2	900 M	20/2 B	-	817 M	-	28	
29		900 M	-	A	90/2	5,720 LM	BREATHE AIRE COMP	30
31	AIR COMP	4,025 M	80/2 B	-	5,720 LM	-	32	
33		4,025 M	-	A	20/2	950 M	SEPTIC PUMP	34
35	WELL PUMP	1,200 M	25/2 B	-	950 M	-	36	
37		1,200 M	-	A	20/1	720 R	RECP - APPARATUS W WALL	38
39	WELL BOOSTER PUMP	600 M	20/2 B	20/1	180 R	RECP - BOOSTER PUMP CONTROLLER	40	
41		600 M	-	A		SPACE	42	

Connected Load: Ph. A 30,722 VA 256 Amps
Connected Load: Ph. B 28,697 VA 239 Amps
Total Demand Load: 59.4 KVA 247.6 Amps

Accessories:
Notes:
1.
2.
3.
4.
5.

Load Type	Load Description	Connected Loads	Subfd Loads (S)	Total Loads	Demand Factor	Demand Load
G	General (Non-Continuous)	9.33	0.75	10.08	100%	10.08 (KVA Typical)
L	Lighting	0.00	1.64	1.64	125%	2.05
R	Receptacles - to 10 KVA over 10 KVA	2.88	9.12	10.00	100%	10.00
K	Kitchen	0.00	11.55	2.00	50%	1.00
H	Heating	9.60	3.50	11.55	70%	8.09
M	Motors	26.17	6.10	13.10	100%	13.10
LM	Largest Motor	11.44	0.00	32.27	100%	32.27
WH	Water Heater	0.00	0.00	11.44	125%	14.30
C	Continuous General Load	0.00	0.00	0.00	125%	0.00
Total:						90.88 KVA

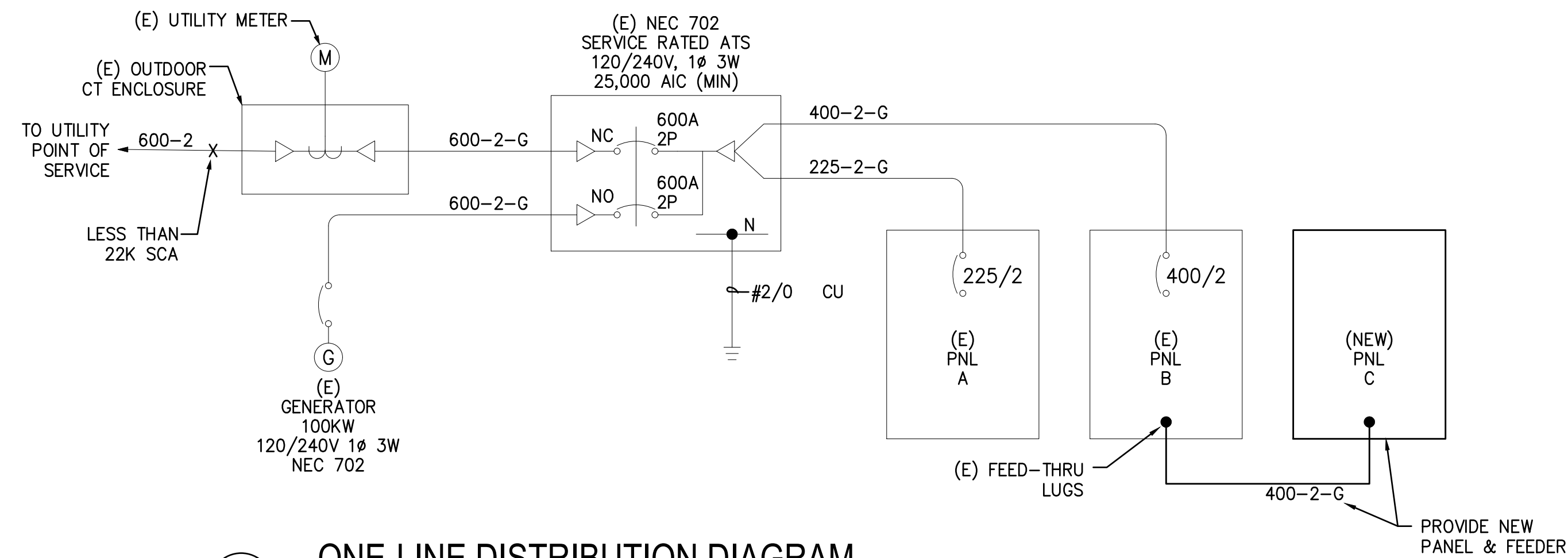

1 ONE-LINE DISTRIBUTION DIAGRAM
SCALE: NTS

FEEDER SCHEDULE	
CALLOUT X-Y-Z	
X = NOMINAL CIRCUIT AMPACITY EG. 225 = 225 AMPERES	Y = CONFIGURATION CODE 1N = 1W + NEUT 1 = 1PH 2W 2 = 1PH 3W 3 = 3PH 3W 4 = 3PH 4W
Z = INDICATES IF GROUND CONDUCTOR(S) ARE INCLUDED G = EQUIPMENT GROUND IG = ISOLATED GROUND	
CALLOUT	DESCRIPTION
600-2	(2) 2 1/2" C-3#350 KCM IN PARALLEL
225-2-G	2" C-3#4/0 + #4 GND
400-2-G	(2) 2" C-3#3/0 + #3 GND IN PARALLEL
600-2-G	(2) 2 1/2" C-3#350 KCM + #1/0 GND IN PARALLEL

Project No: 1927
CONSTRUCTION DOCUMENTS
OCTOBER 2, 2020

REVISION: DATE
1 - REVISION 1 6/11/2020
2 - REVISION 2 10/02/2020

SCHEDULES
&
ONE-LINE

E-501

All material herein constitutes the original and unpublished work of the architect and may not be used, duplicated, or disclosed without the written consent of the architect. Copyright © 2020 by Thomas Architecture Studio. All rights reserved.